

EP 55																		Stadi Steps Stufenzahl				
Stadi Steps Stufenzahl	1					2																
i	3	4	5	7	10	9	12	15	16	20	25	28	35	40	50	70	100	1	2			
T _{2N}	12	14	16	12	10	14	16	16	16	16	16	16	16	16	16	14	12	n _{1nom}	4000			
T _{2A}	22	24	24	22	20	24	28	28	28	28	28	28	28	28	28	24	22	n _{1max}	5000			
T _{2S}	44	48	48	44	40	48	56	56	56	56	56	56	56	56	56	48	44	LpA	< 70			
J	Vedi pag. 31 / See page 31 / Siehe auf Seite 31																	Lh	20000			
R _t	1.0					0.9					1.0							0.9		F _{R2}	300	
R _d	0.96					0.93															F _{A2}	450
Kg	0.8					1.8															α _{max}	8' 10'

2.9 Dimensioni

2.9 Dimensions

2.9 Abmessungen

Dimensioni generali e uscite / General and output dimensions / General-und Abtriebsabmessungen

AA

Flangia uscita
Output flange
Abtriebsflansch

Stadi / Steps / Stufenzahl	1	2	AE= 6 - 6.35 - 7 - 8 - 9 - 9.52 - 11
C1	62.5	81.5	
T	87	106	

TT

Flangia uscita
Output flange
Abtriebsflansch

Stadi / Steps / Stufenzahl	1	2	AE= 6 - 6.35 - 7 - 8 - 9 - 9.52 - 11
C1	63.5	82.5	
T	87	106	

AQ

Flangia uscita
Output flange
Abtriebsflansch

Stadi / Steps / Stufenzahl	1	2	AE= 6 - 6.35 - 7 - 8 - 9 - 9.52 - 11
C1	56	75	
T	87	106	

TQ

Flangia uscita
Output flange
Abtriebsflansch

Stadi / Steps / Stufenzahl	1	2	AE= 6 - 6.35 - 7 - 8 - 9 - 9.52 - 11
C1	56	75	
T	87	106	

Dimensioni entrate / Input dimensions / Antriebsabmessungen

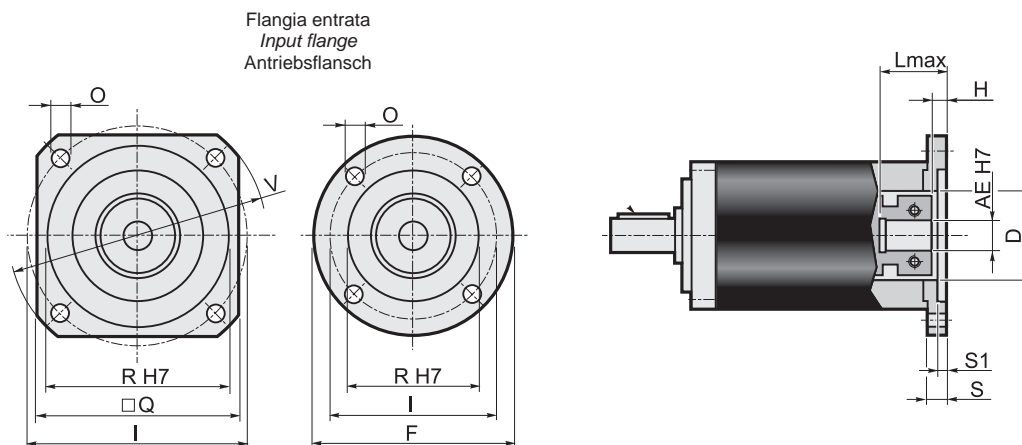

	Flange entrata / Input flange / Antriebsflansch										Albero entrata / Input shaft / Antriebswelle												
											AE												
	F	Q	V	I	R (H7)	O	S	S1	D	6	6.35	7	8	9	9.52	11							
									L _{max}	H	L _{max}	H	L _{max}	H	L _{max}	H	L _{max}	H	L _{max}	H	L _{max}	H	
P01*	60	=	=	43.82	22	4.5	10	3	22	30	7	30	7	30	7	30	7	30	7	30	7	30	7
P02*	=	60	80	66.67	38.1	5.5	10	3	32	30	7	30	7	30	7	30	7	30	7	30	7	30	7
P03*	=	60	80	63	40	5.5	10	3.5	32	30	7	30	7	30	7	30	7	30	7	30	7	30	7
P04	=	70	90	75	60	6.5	10.5	3.5	32	30.5	7.5	30.5	7.5	30.5	7.5	30.5	7.5	30.5	7.5	30.5	7.5	30.5	7.5
P05	105	=	=	85	70	6.5	10.5	3.5	32	30.5	7.5	30.5	7.5	30.5	7.5	30.5	7.5	30.5	7.5	30.5	7.5	30.5	7.5
P06	=	80	110	98.42	73.02	6	11	3.5	35	31	8	31	8	31	8	31	8	31	8	31	8	31	8
P07	=	95	120	100	80	6.5	11.5	4	32	31.5	8.5	31.5	8.5	31.5	8.5	31.5	8.5	31.5	8.5	31.5	8.5	31.5	8.5
P08	=	98	130	115	95	9	11.5	4	32	31.5	8.5	31.5	8.5	31.5	8.5	31.5	8.5	31.5	8.5	31.5	8.5	31.5	8.5
P09	=	116	160	130	110	9	12	4.5	32	32	9	32	9	32	9	32	9	32	9	32	9	32	9
P10*	60	=	=	39	26	4.5	10	3	26	30	7	30	7	30	7	30	7	30	7	30	7	30	7
P11*	60	=	=	42	32	4.5	10	3	32	30	7	30	7	30	7	30	7	30	7	30	7	30	7
P12*	65	=	=	46	32	4.5	10	3.5	32	30	7	30	7	30	7	30	7	30	7	30	7	30	7
P13*	80	=	=	65	50	5.5	10	3.5	32	30	7	30	7	30	7	30	7	30	7	30	7	30	7
P14*	60	=	=	39	20	4.5	10	2.5	20	30	7	30	7	30	7	30	7	30	7	30	7	30	7
P15	=	75	100	90	60	5.8	12	3.5	32	32	9	32	9	32	9	32	9	32	9	32	9	32	9
P16*	60	=	=	45	30	3.5	14	7	30	34	11	34	11	34	11	34	11	34	11	34	11	34	11
P17	=	60	82	70	50	4.5	16.5	8	32	36.5	13.5	36.5	13.5	36.5	13.5	36.5	13.5	36.5	13.5	36.5	13.5	36.5	13.5
P18	=	60	80	60	50	M4	10.5	3.5	32	30.5	7.5	30.5	7.5	30.5	7.5	30.5	7.5	30.5	7.5	30.5	7.5	30.5	7.5
P19*	60	=	=	36	25	4.5	10	3	25	30	7	30	7	30	7	30	7	30	7	30	7	30	7
P20	=	60	82	70	50	5.5	10.5	3.5	32	30.5	7.5	30.5	7.5	30.5	7.5	30.5	7.5	30.5	7.5	30.5	7.5	30.5	7.5
P21*	60	=	=	46	30	4.5	10	3	30	30	7	30	7	30	7	30	7	30	7	30	7	30	7
P22	=	60	80	70.71	36	4.5	10	2	32	30	7	30	7	30	7	30	7	30	7	30	7	30	7
P23	=	62	85	70	50	5.5	15.5	3.5	32	35.5	12.5	35.5	12.5	35.5	12.5	35.5	12.5	35.5	12.5	35.5	12.5	35.5	12.5
P24	=	75	100	90	70	5.8	12	3.5	32	32	9	32	9	32	9	32	9	32	9	32	9	32	9
P25	=	70	95	85	55	5.8	12	3.5	32	32	9	32	9	32	9	32	9	32	9	32	9	32	9
P26*	=	60	80	65.5	34	5.5	10	3.5	33	30	7	30	7	30	7	30	7	30	7	30	7	30	7
P27	=	80	110	95	50	6.5	12	3.5	32	32	9	32	9	32	9	32	9	32	9	32	9	32	9
P28	=	60	80	66.67	38.1	M4	9	2.5	32	29	6	29	6	29	6	29	6	29	6	29	6	29	6
P29	60	=	=	45	30	M3	11	4	32	31	8	31	8	31	8	31	8	31	8	31	8	31	8
P30	=	70	95	85	60	5.8	12	3.5	32	32	9	32	9	32	9	32	9	32	9	32	9	32	9
P31	=	62	85	70	50	M4	11	3.5	32	31	8	31	8	31	8	31	8	31	8	31	8	31	8
P32	=	60	80	65	40	M5	10	3.5	32	30	7	30	7	30	7	30	7	30	7	30	7	30	7
P33	=	85	115	99	60	5.5	11	3.5	35	31	8	31	8	31	8	31	8	31	8	31	8	31	8
P34	=	65	87	73.54	40	M4	10	3.5	32	30	7	30	7	30	7	30	7	30	7	30	7	30	7
P35	=	60	80	70.71	36	M4	14	2	32	34	11	34	11	34	11	34	11	34	11	34	11	34	11
P36	=	85	115	98.42	73.02	6	15	3.5	35	35	12	35	12	35	12	35	12	35	12	35	12	35	12
P38	60	=	=	48	30	M3	11	7	32	31	8	31	8	31	8	31	8	31	8	31	8	31	8

* Per assemblare il motore è necessario smontare la flangia dal riduttore (vedere schema di montaggio 2 a pag. 45).

* Before the mounting of the motor it is necessary to remove the flange from the gearbox (see structural arrangement 2 at the top of the page 45).

* Vor dem Einbauen des Motors soll die Getriebeflang abmontiert werden (siehe Bauanleitung 2 auf Seite 45).

EP 75																		Stadi Steps Stufenzahl			
Stadi Steps Stufenzahl	1					2												1	2		
i	3	4	5	7	10	9	12	15	16	20	25	28	35	40	50	70	100				
T _{2N}	22	28	32	28	20	26	32	36	36	36	36	36	36	36	36	30	22	n _{1nom}	4000		
T _{2A}	40	45	50	45	40	50	60	60	60	60	60	60	60	60	60	50	45	n _{1max}	5000		
T _{2S}	80	90	100	90	80	100	120	120	120	120	120	120	120	120	120	100	90	LpA	< 70		
J	Vedi pag. 31 / See page 31 / Siehe auf Seite 31																	Lh	20000		
R _t	3.5					3.0												3.0		F _{R2}	1800
R _d	0.96					0.93														F _{A2}	1400
Kg	1.4					2.0														α _{max}	8' 10'

Dimensioni generali e uscite / General and output dimensions / General-und Abtriebsabmessungen

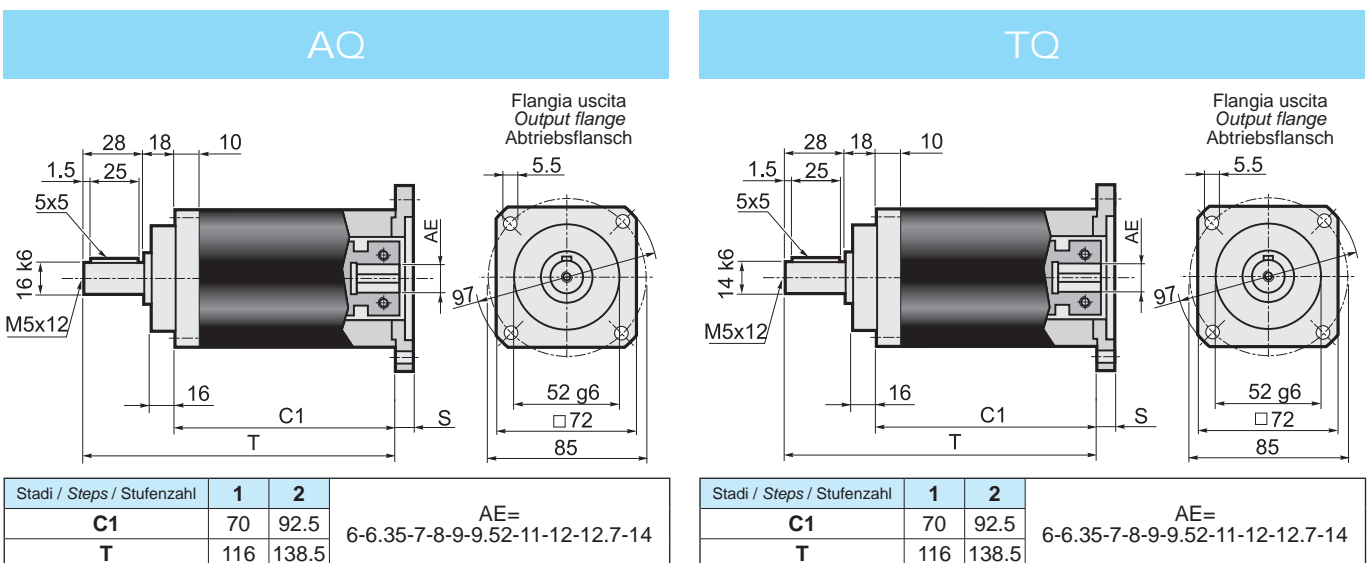
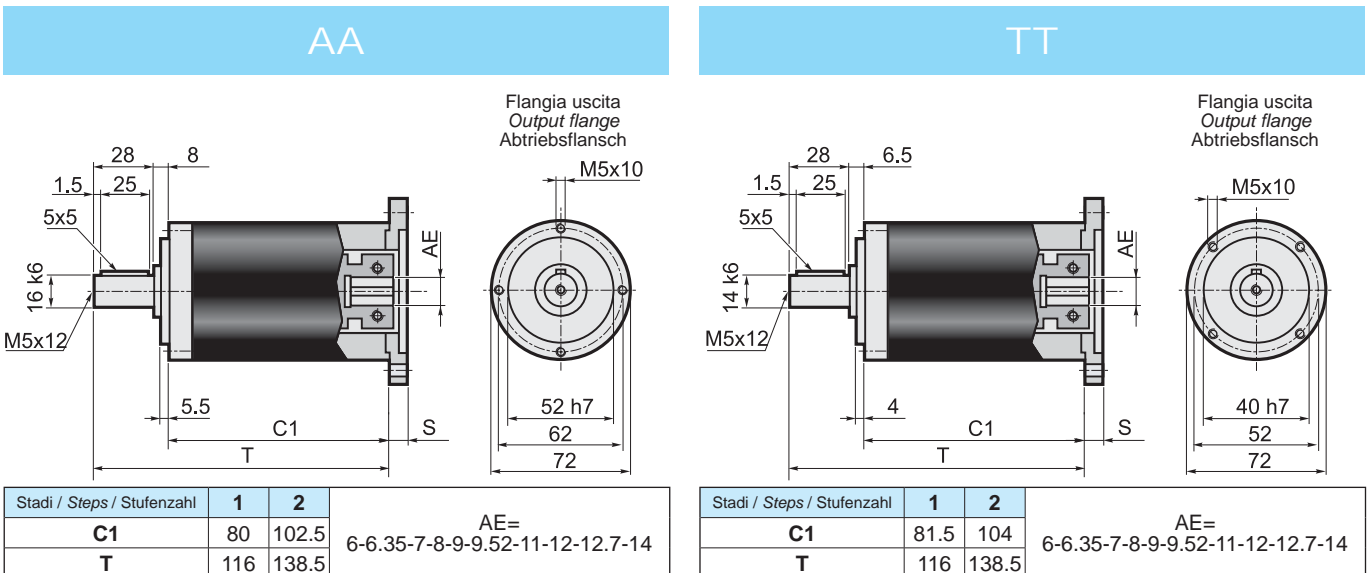

EP 90																		Stadi Steps Stufenzahl			
Stadi Steps Stufenzahl	1					2															
i	3	4	5	7	10	9	12	15	16	20	25	28	35	40	50	70	100	1	2		
T _{2N}	50	55	60	55	50	65	70	75	75	75	75	75	75	75	75	65	55	n _{1nom}	4000		
T _{2A}	80	90	100	90	80	100	110	120	120	120	120	120	120	120	120	100	90	n _{1max}	5000		
T _{2S}	160	180	200	180	160	200	220	240	240	240	240	240	240	240	240	200	180	LpA	< 70		
J	Vedi pag. 32 / See page 32 / Siehe auf Seite 32																Lh	20000			
R _t	9.0				7.5				9.0								7.5		F _{R2}	2600	
R _d	0.96					0.93														F _{A2}	2000
Kg	2.8					3.7														α _{max}	8' 10'

2.9 Dimensioni

2.9 Dimensions

2.9 Abmessungen

Dimensioni generali e uscite / General and output dimensions / General-und Abtriebsabmessungen

AA

Flangia uscita
Output flange
Abtriebsflansch

Stadi / Steps / Stufenzahl	1	2	AE=	
C1	98	127	9-9.52-11-12-12.7-14-15.87-16-19	
T	144	173		

TT

Flangia uscita
Output flange
Abtriebsflansch

Stadi / Steps / Stufenzahl	1	2	AE=	
C1	101	130	9-9.52-11-12-12.7-14-15.87-16-19	
T	144	173		

AQ

Flangia uscita
Output flange
Abtriebsflansch

Stadi / Steps / Stufenzahl	1	2	AE=	
C1	88	117	9-9.52-11-12-12.7-14-15.87-16-19	
T	144	173		

TQ

Flangia uscita
Output flange
Abtriebsflansch

Stadi / Steps / Stufenzahl	1	2	AE=	
C1	88	117	9-9.52-11-12-12.7-14-15.87-16-19	
T	144	173		

Dimensioni entrate / Input dimensions / Antriebsabmessungen

Flangia entrata
Input flange
Antriebsflansch

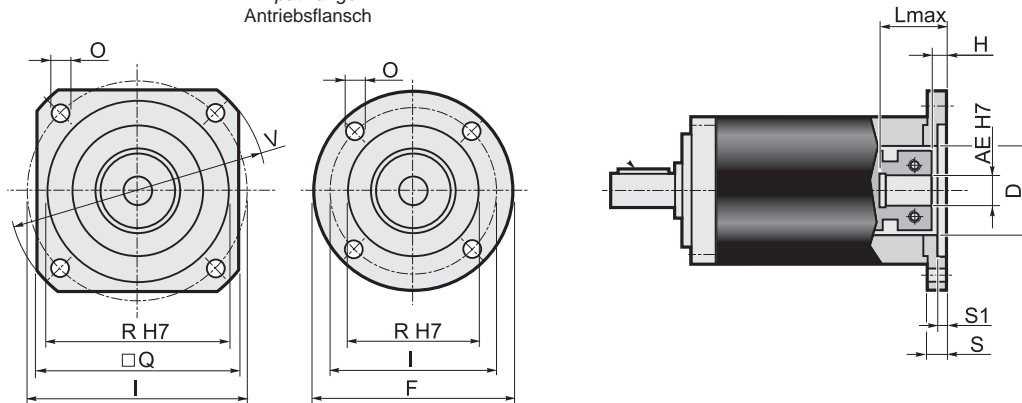

	Flange entrata / Input flange / Antriebsflansch									Albero entrata / Input shaft / Antriebswelle																	
										AE																	
										9		9.525		11		12		12.7		14		15.87		16		19	
F	Q	V	I	R (H7)	O	S	S1	D	L _{max}	H	L _{max}	H	L _{max}	H	L _{max}	H	L _{max}	H	L _{max}	H	L _{max}	H	L _{max}	H			
P01*	80	=	=	66.67	38.1	5.5	12	3	38.1	44	6.5	44	9	29	9	44	9	44	9	44	9	44	9	44	9	44	9
P02	=	106.5	140	125.72	55.52	7	11	3	45	43	5.5	43	8	28	8	43	8	43	8	43	8	43	8	43	8	43	8
P03*	=	80	90	75	60	5.5	12	3.5	45	44	6.5	44	9	29	9	44	9	44	9	44	9	44	9	44	9	44	9
P04*	105	=	=	85	70	6.5	12	3.5	45	44	6.5	44	9	29	9	44	9	44	9	44	9	44	9	44	9	44	9
P05	=	82.5	110	98.425	73.02	6.5	12	3	45	44	6.5	44	9	29	9	44	9	44	9	44	9	44	9	44	9	44	9
P06	=	90	120	100	80	6.5	13	4	45	45	7.5	45	10	30	10	45	10	45	10	45	10	45	10	45	10	45	10
P07	=	100	135	115	95	8.5	13	4.5	45	45	7.5	45	10	30	10	45	10	45	10	45	10	45	10	45	10	45	10
P08	=	116	160	130	110	9	13	4.5	45	45	7.5	45	10	30	10	45	10	45	10	45	10	45	10	45	10	45	10
P09*	80	=	=	39	26	4.5	12	4	26	44	6.5	44	9	29	9	44	9	44	9	44	9	44	9	44	9	44	9
P10*	80	=	=	65	50	5.5	12	3.5	45	44	6.5	44	9	29	9	44	9	44	9	44	9	44	9	44	9	44	9
P11	=	150	182	166	115	9	32	11	50x14	64	26.5	64	29	49	29	64	29	64	29	64	29	64	29	64	29	64	29
P12*	=	80	105	90	70	6.5	12	3.5	32	44	6.5	44	9	29	9	44	9	44	9	44	9	44	9	44	9	44	9
P14*	105	=	=	90	70	6	19	9	32	51	13.5	51	16	36	16	51	16	51	16	51	16	51	16	51	16	51	16
P15*	80	=	=	70	50	4.5	17	8	45	49	11.5	49	14	34	14	49	14	49	14	49	14	49	14	49	14	49	14
P16	=	142	190	165	130	11	13	4.5	45	45	7.5	45	10	30	10	45	10	45	10	45	10	45	10	45	10	45	10
P17*	80	=	=	63	40	5.5	12	3.5	40	44	6.5	44	9	29	9	44	9	44	9	44	9	44	9	44	9	44	9
P18	=	130	170	145	110	M8	31	7	32	63	25.5	63	28	48	28	63	28	63	28	63	28	63	28	63	28	63	28
P19*	=	80	105	90	60	6.5	12	3.5	32	44	6.5	44	9	29	9	44	9	44	9	44	9	44	9	44	9	44	9
P20*	=	80	105	85	55	5.5	12	3.5	36	44	6.5	44	9	29	9	44	9	44	9	44	9	44	9	44	9	44	9
P21	=	80	110	95	50	M6	12	3.5	45	44	6.5	44	9	29	9	44	9	44	9	44	9	44	9	44	9	44	9
P22	80	=	=	70	50	M4	12	4	45	44	6.5	44	9	29	9	44	9	44	9	44	9	44	9	44	9	44	9
P23	=	80	90	75	60	M5	12	3.5	45	44	6.5	44	9	29	9	44	9	44	9	44	9	44	9	44	9	44	9
P24	80	=	=	46	30	M4	12	4	30	44	6.5	44	9	29	9	44	9	44	9	44	9	44	9	44	9	44	9
P26	80	=	=	65	40	M5	12	3.5	40	44	6.5	44	9	29	9	44	9	44	9	44	9	44	9	44	9	44	9
P27	=	80	105	82.02	36.8	M6	14	10	36.8	46	8.5	46	11	31	11	46	11	46	11	46	11	46	11	46	11	46	11
P28	=	90	120	100	80	6.5	28	4	45	60	22.5	60	25	45	25	60	25	60	25	60	25	60	25	60	25	60	25
P29*	80	=	=	66.67	50	5.5	12	3	45	44	6.5	44	9	29	9	44	9	44	9	44	9	44	9	44	9	44	9
P30	=	115	155	130	80	9	13	4	45	45	7.5	45	10	30	10	45	10	45	10	45	10	45	10	45	10	45	10
P31*	=	80	105	56	44	M6	14	10	36.8	46	8.5	46	11	31	11	46	11	46	11	46	11	46	11	46	11	46	11
P32	=	80	105	90	70	M6	12	3.5	32	44	6.5	44	9	29	9	44	9	44	9	44	9	44	9	44	9	44	9
P33	=	130	165	145	110	9	13	4.5	45	45	7.5	45	10	30	10	45	10	45	10	45	10	45	10	45	10	45	10
P34	=	90	120	100	80	M6	19	5	45	51	13.5	51	16	36	16	51	16	51	16	51	16	51	16	51	16	51	16
P36	=	100	135	115	95	M8	25	4.5	45	57	19.5	57	22	42	22	57	22	57	22	57	22	57	22	57	22	57	22
P37	=	85	115	98.99	60	M6	12	3.5	32	44	6.5	44	9	29	9	44	9	44	9	44	9	44	9	44	9	44	9

* Per assemblare il motore è necessario smontare la flangia dal riduttore (vedere schema di montaggio 2 a pag. 45).

* Before the mounting of the motor it is necessary to remove the flange from the gearbox (see structural arrangement 2 at the top of the page 45).

* Vor dem Einbauen des Motors soll die Getriebeflangens abmontiert werden (siehe Bauanleitung 2 auf Seite 45).

EP 120																		Stadi Steps Stufenzahl	
Stadi Steps Stufenzahl	1					2													
i	3	4	5	7	10	9	12	15	16	20	25	28	35	40	50	70	100	1	2
T _{2N}	120	150	180	150	100	150	180	220	220	220	220	220	220	220	220	170	110	n _{1nom}	3000
T _{2A}	190	240	290	220	180	240	290	350	350	350	350	350	350	350	350	270	200	n _{1max}	4000
T _{2S}	400	500	600	460	380	500	600	700	700	700	700	700	700	700	700	540	400	LpA	< 70
J	Vedi pag. 32 / See page 32 / Siehe auf Seite 32																	Lh	20000
R _t	32				28	32	30						28					F _{R2}	4500
R _d	0.96					0.93												F _{A2}	4000
Kg	7.5					8.0												α _{max}	8' 10'

2.9 Dimensioni

2.9 Dimensions

2.9 Abmessungen

Dimensioni generali e uscite / General and output dimensions / General-und Abtriebsabmessungen

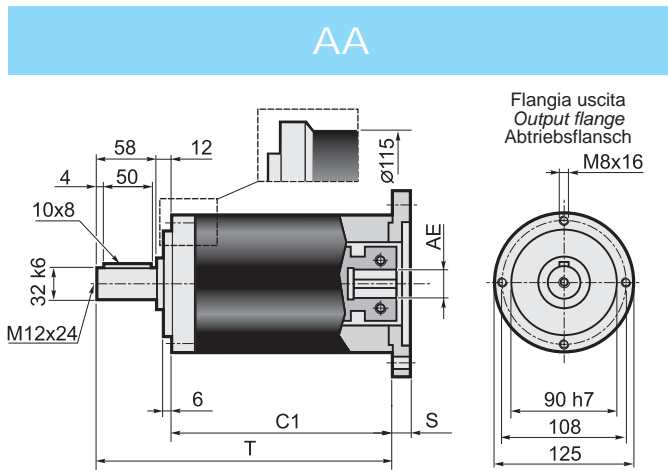

Stadi / Steps / Stufenzahl	1	2	AE= 12.7-14-15.87-16-19
C1	115.8	148.4	
T	185.8	218.4	
Stadi / Steps / Stufenzahl	1	2	AE= 22-24-25-28
C1	115.8	148.4	
T	185.8	218.4	

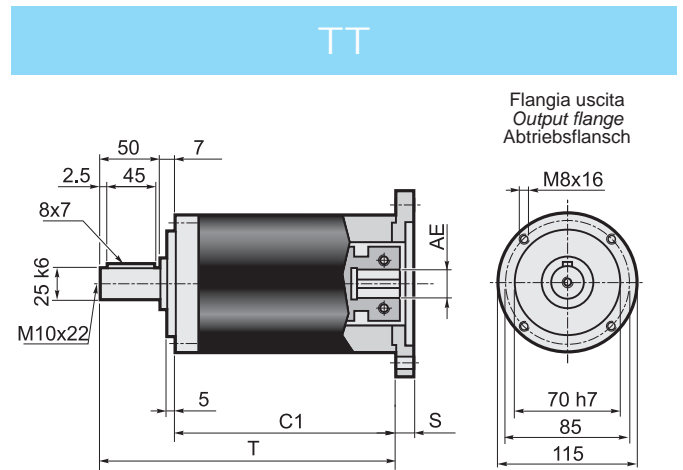

Stadi / Steps / Stufenzahl	1	2	AE= 12.7-14-15.87-16-19
C1	120.8	153.4	
T	177.8	210.4	
Stadi / Steps / Stufenzahl	1	2	AE= 22-24-25-28
C1	139.8	172.4	
T	196.8	229.4	

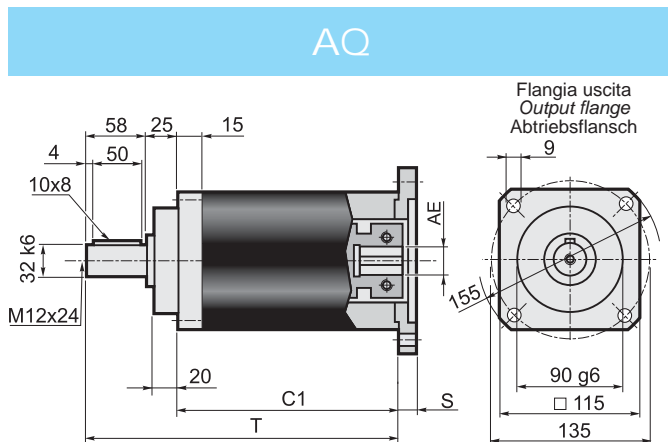

Stadi / Steps / Stufenzahl	1	2	AE= 12.7-14-15.87-16-19
C1	102.8	135.4	
T	185.8	218.4	
Stadi / Steps / Stufenzahl	1	2	AE= 22-24-25-28
C1	121.8	154.4	
T	204.8	237.4	

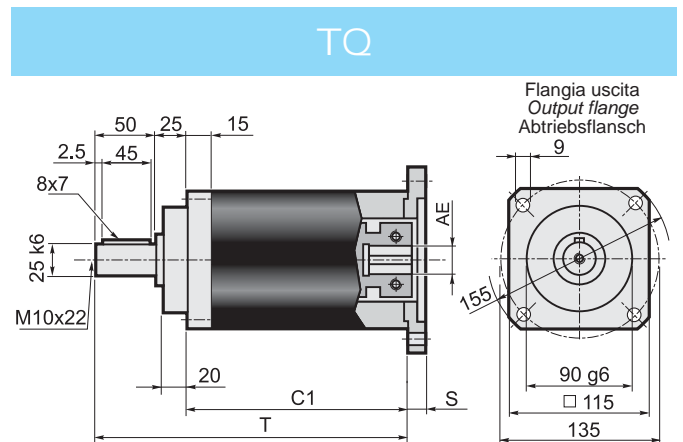

Stadi / Steps / Stufenzahl	1	2	AE= 12.7-14-15.87-16-19
C1	102.8	135.4	
T	177.8	210.4	
Stadi / Steps / Stufenzahl	1	2	AE= 22-24-25-28
C1	121.8	154.4	
T	196.8	229.4	

Dimensioni entrate / Input dimensions / Antriebsabmessungen

Flangia entrata
Input flange
Antriebsflansch

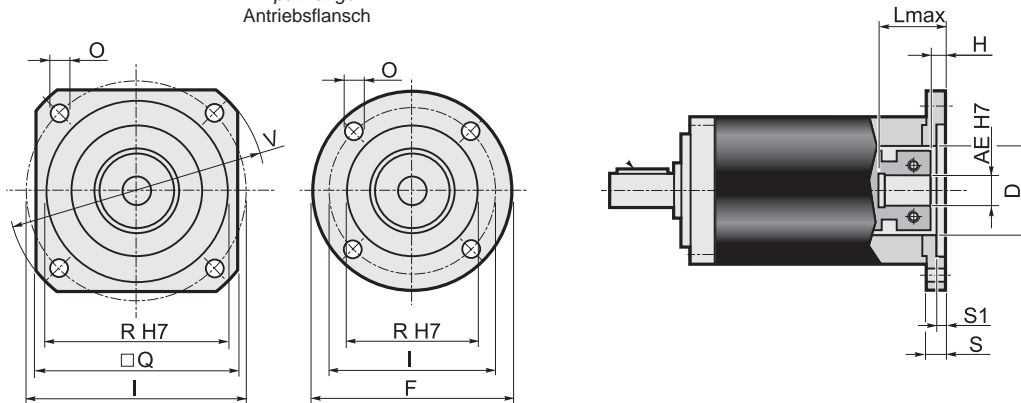

Flange entrata / Input flange / Antriebsflansch										Albero entrata / Input shaft / Antriebswelle															
										AE															
										12.7		14		15.87		16		19		22		24		25	
F	Q	V	I	R (H7)	O	S	S1	D	L _{max}	H	L _{max}	H	L _{max}	H	L _{max}	H	L _{max}	H	L _{max}	H	L _{max}	H	L _{max}	H	
P01*	=	115	140	125.72	55.52	6.5	13	3	55.52	43	6	35	6	43	6	43	6	43	6	62	6	62	6	62	6
P02*	115	=	=	75	60	5.5	13	3.5	60	43	6	35	6	43	6	43	6	43	6	62	6	62	6	62	6
P03*	115	=	=	85	70	6.5	13	3.5	60	43	6	35	6	43	6	43	6	43	6	62	6	62	6	62	6
P04*	115	=	=	98.42	73.02	6.5	13	3	60	43	6	35	6	43	6	43	6	43	6	62	6	62	6	62	6
P05*	120	=	=	100	80	6.5	13	4	60	43	6	35	6	43	6	43	6	43	6	62	6	62	6	62	6
P06*	=	115	140	115	95	9	13	4.5	60	43	6	35	6	43	6	43	6	43	6	62	6	62	6	62	6
P07	=	115	160	130	110	8.5	13	4.5	60	43	6	35	6	43	6	43	6	43	6	62	6	62	6	62	6
P08	=	142	190	165	130	11	13	4.5	60	43	6	35	6	43	6	43	6	43	6	62	6	62	6	62	6
P09	=	192	250	215	180	13	14	4.5	60	44	7	36	7	44	7	44	7	44	7	63	7	63	7	63	7
P10*	115	=	=	65	50	6.5	13	3.5	50	43	6	35	6	43	6	43	6	43	6	62	6	62	6	62	6
P11	=	130	170	145	110	M 8	31	7	60	61	24	53	24	61	24	61	24	61	24	80	24	80	24	80	24
P12	=	130	170	145	110	M 8	17	7	60	47	10	39	10	47	10	47	10	47	10	66	10	66	10	66	10
P13	=	115	160	130	110	M 8	13	4.5	60	43	6	35	6	43	6	43	6	43	6	62	6	62	6	62	6
P14*	115	=	=	70	50	6.5	13	3.5	50	43	6	35	6	43	6	43	6	43	6	62	6	62	6	62	6
P15	115	=	=	90	70	M5	11	3.5	60	41	4	33	4	41	4	41	4	41	4	60	4	60	4	60	4
P17*	115	=	=	90	70	6.5	13	3.5	60	43	6	35	6	43	6	43	6	43	6	62	6	62	6	62	6
P18	=	115	155	130	95	8.5	13	4.5	60	43	6	35	6	43	6	43	6	43	6	62	6	62	6	62	6
P19*	115	=	=	95	50	6.5	13	3.5	50	43	6	35	6	43	6	43	6	43	6	62	6	62	6	62	6
P20	115	=	=	99	60	M6	13	4	60	43	6	35	6	43	6	43	6	43	6	62	6	62	6	62	6
P21*	130	=	=	106	82.5	12.5	26.3	15	60	56.5	19.5	48.5	19.5	56.5	19.5	56.5	19.5	56.5	19.5	75.5	19.5	75.5	19.5	75.5	19.5
P22	=	144	190	165	110	11	15	4.5	60	45	8	37	8	45	8	45	8	45	8	64	8	64	8	64	8
P23*	115	=	=	63	40	5.5	11	3.5	40	41	4	33	4	41	4	41	4	41	4	60	4	60	4	60	4
P24	120	=	=	100	80	M6	18	7	60	48	11	40	11	48	11	48	11	48	11	67	11	67	11	67	11

* Per assemblare il motore è necessario smontare la flangia dal riduttore (vedere schema di montaggio 2 a pag. 45).

* Before the mounting of the motor it is necessary to remove the flange from the gearbox (see structural arrangement 2 at the top of the page 45).

* Vor dem Einbauen des Motors soll die Getriebeflang abmontiert werden (siehe Bauanleitung 2 auf Seite 45).

EP 155																			Stadi Steps Stufenzahl	
Stadi Steps Stufenzahl	1					2														
i	3	4	5	7	10	9	12	15	16	20	25	28	35	40	50	70	100	1	2	
T _{2N}	240	320	380	300	220	320	400	500	500	500	500	500	500	500	500	350	250	n _{1nom}	3000	
T _{2A}	420	540	600	480	400	480	600	750	750	750	750	750	750	750	750	560	460	n _{1max}	4000	
T _{2S}	880	1140	1260	1000	850	1000	1250	1500	1500	1500	1500	1500	1500	1500	1500	1120	920	LpA	< 70	
J	Vedi pag. 33 / See page 33 / Siehe auf Seite 33																	Lh	20000	
R _t	60				50	60											50	F _{R2} (AA)	6500	
																		F _{R2} (TT)	5300	
R _d	0.96					0.93												F _{A2} (AA)	3250	
																		F _{A2} (TT)	2650	
Kg	10.9					15.7												α _{max}	8' 10'	

2.9 Dimensioni

2.9 Dimensions

2.9 Abmessungen

Dimensioni generali e uscite / General and output dimensions / General-und Abtriebsabmessungen

AA

Flangia uscita
Output flange
Abtriebsflansch
M10x20

Stadi / Steps / Stufenzahl	1	2	AE=
C1	156	197.5	15.87-16-19-22-24
T	251	292.5	
C1	181	222.5	AE=
T	276	317.5	28-32-35-38

TT

Flangia uscita
Output flange
Abtriebsflansch
M12x20

Stadi / Steps / Stufenzahl	1	2	AE=
C1	156	197.5	15.87-16-19-22-24
T	226	267.5	
C1	181	222.5	AE=
T	251	292.5	28-32-35-38

AQ

Flangia uscita
Output flange
Abtriebsflansch
M12x20

Stadi / Steps / Stufenzahl	1	2	AE=
C1	141	182.5	15.87-16-19-22-24
T	251	292.5	
C1	166	207.5	AE=
T	276	317.5	28-32-35-38

Dimensioni entrate / Input dimensions / Antriebsabmessungen

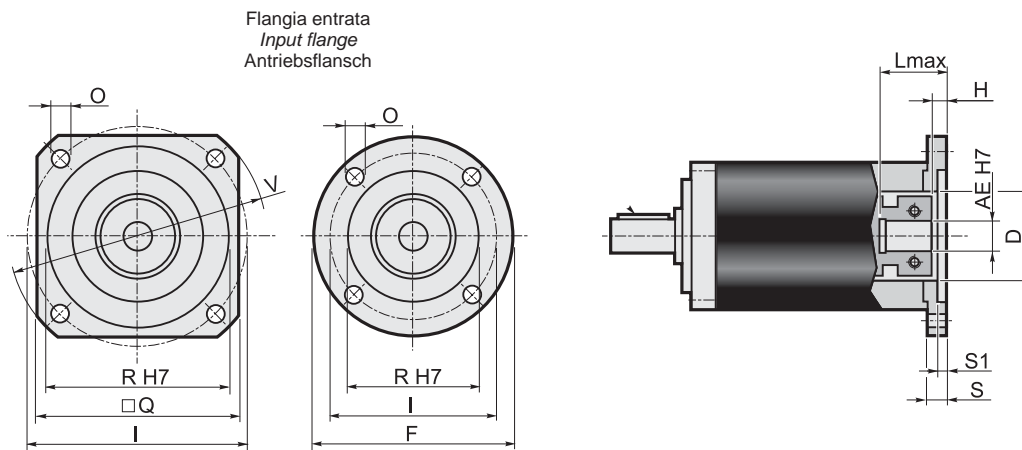

Flange entrata / Input flange / Antriebsflansch										Albero entrata / Input shaft / Antriebswelle																			
										AE																			
										15.87		16		19		22		24		28		32		35		38			
F	Q	V	I	R (H7)	O	S	S1	D		L _{max}	H	L _{max}	H	L _{max}	H	L _{max}	H	L _{max}	H	L _{max}	H	L _{max}	H	L _{max}	H	L _{max}	H		
P01*	140	=	=	125.72	55.52	6.5	15	4	55.52	57.8	6.8	57.8	6.8	42.8	6.8	57.8	6.8	57.8	6.8	82.8	7.3	82.8	7.3	82.8	7.3	82.8	7.3	82.8	7.3
P02*	140	=	=	100	80	6.5	15	4	70	57.8	6.8	57.8	6.8	42.8	6.8	57.8	6.8	57.8	6.8	82.8	7.3	82.8	7.3	82.8	7.3	82.8	7.3	82.8	7.3
P03*	140	=	=	115	95	8.5	15	4.5	70	57.8	6.8	57.8	6.8	42.8	6.8	57.8	6.8	57.8	6.8	82.8	7.3	82.8	7.3	82.8	7.3	82.8	7.3	82.8	7.3
P04*	=	140	160	130	110	8.5	15	4.5	70	57.8	6.8	57.8	6.8	42.8	6.8	57.8	6.8	57.8	6.8	82.8	7.3	82.8	7.3	82.8	7.3	82.8	7.3	82.8	7.3
P05	=	142	190	165	130	11	15	4.5	70	57.8	6.8	57.8	6.8	42.8	6.8	57.8	6.8	57.8	6.8	82.8	7.3	82.8	7.3	82.8	7.3	82.8	7.3	82.8	7.3
P06	=	190	250	215	180	13	15	4.5	70	57.8	6.8	57.8	6.8	42.8	6.8	57.8	6.8	57.8	6.8	82.8	7.3	82.8	7.3	82.8	7.3	82.8	7.3	82.8	7.3
P07	=	250	300	265	230	13	15	4.5	70	57.8	6.8	57.8	6.8	42.8	6.8	57.8	6.8	57.8	6.8	82.8	7.3	82.8	7.3	82.8	7.3	82.8	7.3	82.8	7.3
P08	=	130	165	145	110	M 8	18	7	70	60.8	9.8	60.8	9.8	45.8	9.8	60.8	9.8	60.8	9.8	85.8	10.3	85.8	10.3	85.8	10.3	85.8	10.3	85.8	10.3
P09	=	180	230	200	114.3	13.5	22	11	70	64.8	13.8	64.8	13.8	49.8	13.8	64.8	13.8	64.8	13.8	89.8	14.3	89.8	14.3	89.8	14.3	89.8	14.3	89.8	14.3
P10	=	115	150	130	95	M 8	15	4.5	70	57.8	6.8	57.8	6.8	42.8	6.8	57.8	6.8	57.8	6.8	82.8	7.3	82.8	7.3	82.8	7.3	82.8	7.3	82.8	7.3
P11	=	180	230	198	155	13.5	22	7	120x11	64.8	13.8	64.8	13.8	49.8	13.8	64.8	13.8	64.8	13.8	89.8	14.3	89.8	14.3	89.8	14.3	89.8	14.3	89.8	14.3
P12	=	220	270	235	200	13.5	15	5	70	57.8	6.8	57.8	6.8	42.8	6.8	57.8	6.8	57.8	6.8	82.8	7.3	82.8	7.3	82.8	7.3	82.8	7.3	82.8	7.3
P13	=	190	250	215	130	13	15	4.5	70	57.8	6.8	57.8	6.8	42.8	6.8	57.8	6.8	57.8	6.8	82.8	7.3	82.8	7.3	82.8	7.3	82.8	7.3	82.8	7.3
P14	=	142	190	165	110	11	15	4.5	70	57.8	6.8	57.8	6.8	42.8	6.8	57.8	6.8	57.8	6.8	82.8	7.3	82.8	7.3	82.8	7.3	82.8	7.3	82.8	7.3
P15*	150	=	=	90	70	6.5	15	4	70	57.8	6.8	57.8	6.8	42.8	6.8	57.8	6.8	57.8	6.8	82.8	7.3	82.8	7.3	82.8	7.3	82.8	7.3	82.8	7.3
P16	=	146	200	177.8	114.3	10.5	15	3.5	70	57.8	6.8	57.8	6.8	42.8	6.8	57.8	6.8	57.8	6.8	82.8	7.3	82.8	7.3	82.8	7.3	82.8	7.3	82.8	7.3

* Per assemblare il motore è necessario smontare la flangia dal riduttore (vedere schema di montaggio 2 a pag. 45).

* Before the mounting of the motor it is necessary to remove the flange from the gearbox (see structural arrangement 2 at the top of the page 45).

* Vor dem Einbauen des Motors soll die Getriebeflang abmontiert werden (siehe Bauanleitung 2 auf Seite 45).