

3.7 Dimensioni

3.7 Dimensions

3.7 Abmessungen

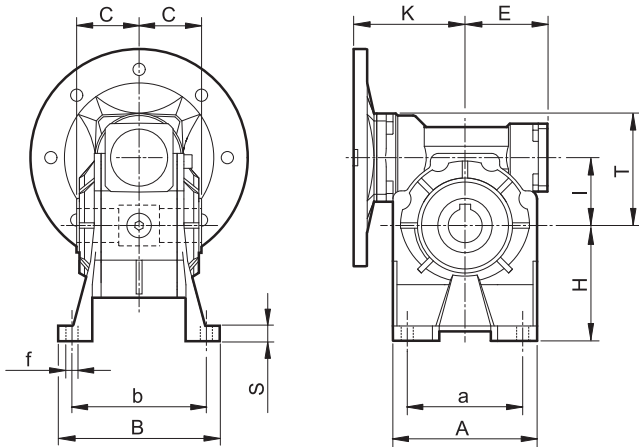

KC..A

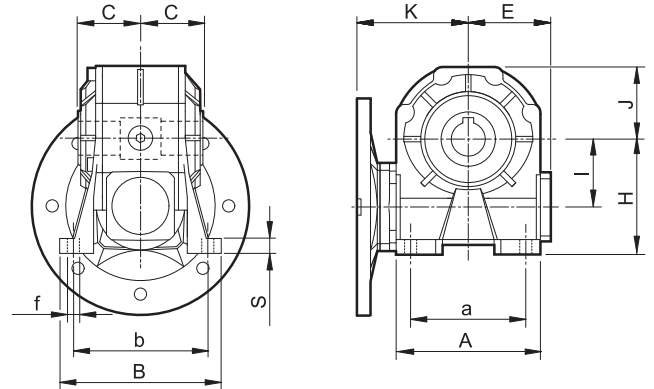

KC..B

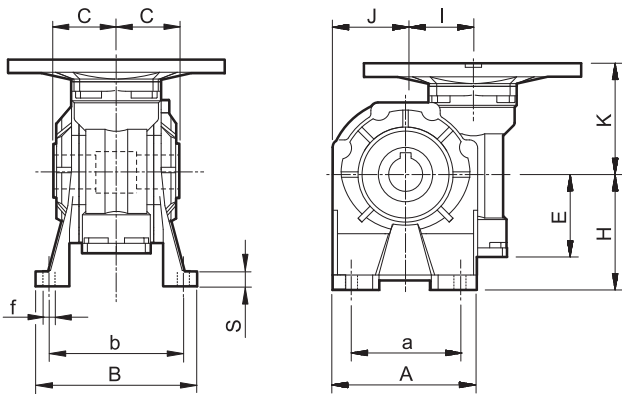

KC..V

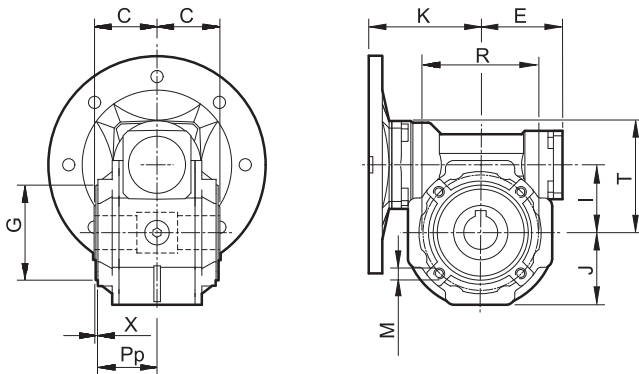

Flangia pendolare / Side cover for shaft mounting / Aufsteckflansch

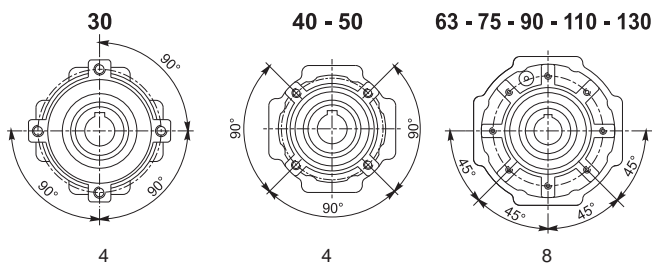

Fori / Holes / Bohrungen Fori / Holes / Bohrungen Fori / Holes / Bohrungen

KC..P

	30	40	50	63	75	90	110	130
b2	5	6 (6)	8 (8)	8	8 (8)	10	12	14
C	31.5	39	46	56	60	70	77.5	85
D2 H7	14	18 (19)	25 (24)	25	28 (30)	35	42	45 (48)
E	41	51	60	71	85	103	127.5	147.5
G h8	55	60	70	80	95	110	130	180
I	31.5	40	50	63	75	90	110	130
J	37.5	43.5	53.5	64	78	100	122	131
K	57	75	82	97	114	122	153	173
M	M6x8	M6x10	M8x10	M8x14	M8x14	M10x18	M10x18	M12x20
Pp	29	36.5	43.5	53	57	67	74	81
R	65	75	85	95	115	130	165	215
T	52.5	68.5	82.5	100.5	116.5	131.5	161.5	181
t2	16.3	20.8 (21.8)	28.3 (27.3)	28.3	31.3 (33.3)	38.3	45.3	48.8 (51.8)
X	1.5	1.5	1.5	2	2	2	2.5	3

	Piedi Feet Fuß	30	40	50	63	75	90	110	130
A	1	67	86.5	106	127.5	155.5	190	250	295
	2	67	86.5	106			190	250	
a	1	40-52	70	63-85	95	120	140	200	235
	2	40-52	52	63-85			140	200	220
B	1	78	98	119	136	140	168	210	229
	2	78	98	119			168	210	
b	1	66	84	99	111	115	140	162	190
	2	66	81	99			146	181	
f	1	6.5	7	9	11	11	13	13	15
	2	6.5	8.5	9			11	13	
H	1	52	71	85	100	115	135	172	200
	2	55	72	82			142	170	
S	1	5	9	11	12	12	14	17	20
	2	8	10	8			14	15	

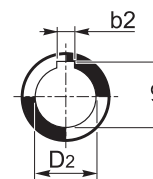

Albero uscita cavo
Hollow output shaft
Abtriebshohlwelle

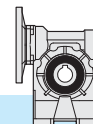

3.7 Dimensioni

3.7 Dimensions

3.7 Abmessungen

Flangia uscita / Output flange / Abtriebsflansch

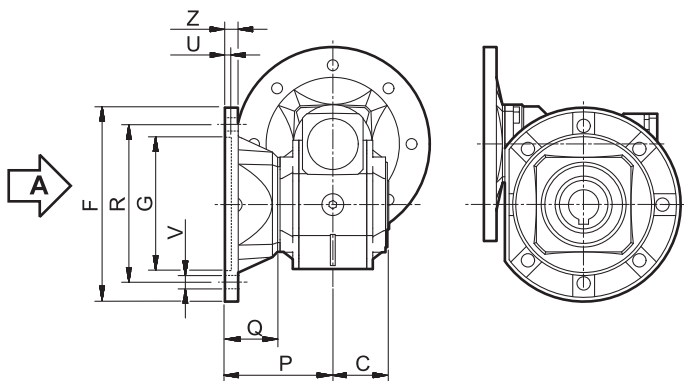

KC..F

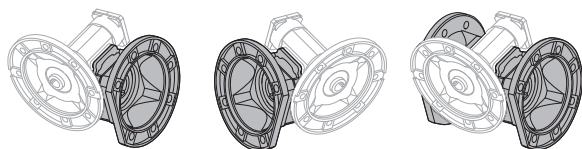

F...D
Standard

F...S

F...2

Vista da A / View from A / Ansicht von A

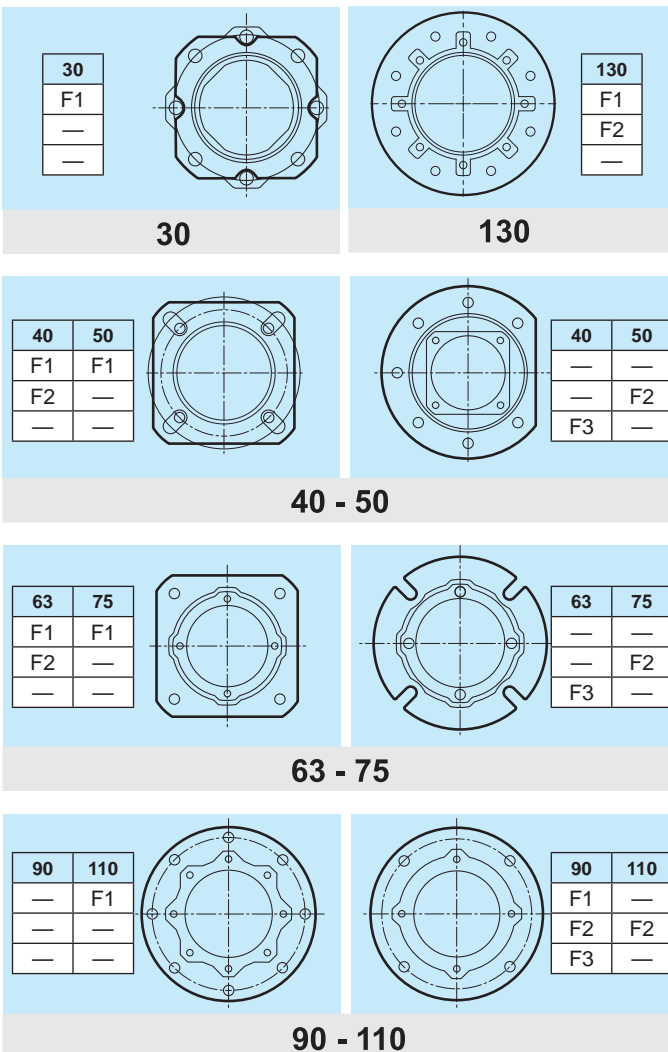

KC	C	F		G H8	P	Q	R	U	V			Z
											Ø	
30	31.5		66	50	54.5	23	68	4			6.5	6
40	39		85	60	67	28	75-90	4			9	8
			85	60	97	58	75-90	4			9	8
			140	95	80	41	115	5			9	10
50	46		94	70	90	44	85-100	5			11	10
			160	110	89	43	130	5			11	11
63	56		142	115	82	26	150	5			11	11
			142	115	112	56	150	5			11	11
			160	110	80.5	24.5	130	5			11	12
75	60		160	130	111	51	165	5			13	12
			160	110	90	30	130	6			11	13
90	70		200	152	111	41	175	5			13	12
			200	152	151	81	175	5			13	13
			200	130	110	40	165	6			11	11
110	77.5		260	170	131	53.5	230	6			13	15
			250	180	150	72.5	215	5			15	16
130	85		320	180	140	55	255	7			16	16
			300	230			265					

* Foratura ruotata di 22.5°

* Drilling turned of 22.5°

* Durchbohrung 22.5° versetzt

