

Stadi Steps Stufenzahl	1				2								3									
i	3	4	5	6	9	12	16	20	24	30	36	27	36	48	64	80	100	120	144	180	216	
n_{1 nom}	4000				4500								5000									
n_{1 max}	6000																					
T_{2N}	35	45	35	30	40	50	50	50	50	40	35	40	55	55	55	55	55	55	55	40	35	
T_{2A}	55	65	55	50	60	70	70	70	70	60	55	60	80	80	80	80	80	80	80	60	55	
T_{2S}	110	130	110	100	120	140	140	140	140	120	110	120	150	150	150	150	150	150	150	120	110	
J	Vedi pag. 14 / See page 14 / Siehe auf Seite 14																					
LpA	< 70																					
R_d	0.96				0.93								0.91									
L_h	20000																					
F_{R2}	1400																					
F_{A2}	700																					
R_t	4																					
α_{max}	4'				6'								8'									
Kg	1.3				1.6								1.9									

i	Rapporto di riduzione nominale	<i>Nominal ratio</i>	Nenn-Untersetzungsverhältnis
n_{1 nom}	Velocità nominale in entrata [min ⁻¹]	<i>Nominal input speed [min⁻¹]</i>	Nenn-Eingangsdrehzahl [min ⁻¹]
n_{1 max}	Velocità massima in entrata [min ⁻¹]	<i>Maximum input speed [min⁻¹]</i>	Maximale Eingangsdrehzahl [min ⁻¹]
T_{2N}	Coppia nominale intermittente in uscita [Nm]	<i>Rated intermittent output torque [Nm]</i>	Nenn-Abtriebsmoment (im Aussetzbetrieb)[Nm]
T_{2A}	Coppia massima di accelerazione in uscita [Nm]	<i>Maximum acceleration output torque [Nm]</i>	Maximales Beschleunigungsmoment am Abtrieb [Nm]
T_{2S}	Coppia massima di emergenza in uscita [Nm]	<i>Maximum emergency output torque [Nm]</i>	Maximale Überlast am Abtrieb [Nm]
LpA	Livello di rumorosità dB(A) a 3000 min ⁻¹	<i>Noise level dB(A) at 3000 min⁻¹</i>	Geräuschpegel dB(A) bei 3000 min ⁻¹
R_d	Rendimento dinamico	<i>Dynamic efficiency</i>	Dynamischer Wirkungsgrad
L_h	Durata cuscinetti [h]	<i>Bearing life [h]</i>	Lebensdauer der Lager [h]
F_{R2}	Carico radiale nominale in uscita [N] a 300min ⁻¹	<i>Rated output radial load [N] at 300min⁻¹</i>	Nenn-Radiallast an der Abtriebswelle bei 300min ⁻¹
F_{A2}	Carico assiale in uscita [N] a 300min ⁻¹	<i>Output axial load [N] at 300min⁻¹</i>	Axiallast an der Abtriebswelle bei 300min ⁻¹
R_t	Rigidità torsionale [Nm / arcmin]	<i>Torsional stiffness [Nm / arcmin]</i>	Drehfestigkeit [Nm / arcmin]
α_{max}	Gioco angolare massimo [arcmin]	<i>Maximum backlash [arcmin]</i>	Maximale Winkelspiel [arcmin]
J	Momento d'inerzia [kg.cm ²]	<i>Moment of inertia [kg.cm²]</i>	Trägheitsmoment [kg.cm ²]

1.10 Dimensioni

1.10 Dimensions

1.10 Abmessungen

Dimensioni generali e uscite / General and output dimensions / General-und Abtriebsabmessungen

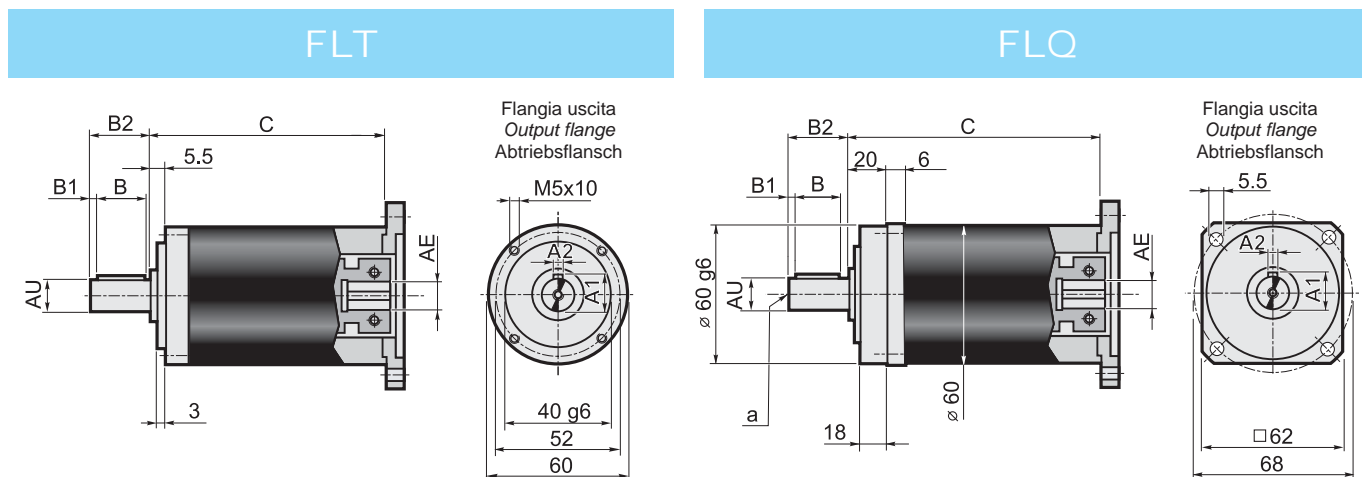

Stadi / Steps / Stufenzahl	1	2	3	
C	83.2	100.9	118.6	AE= 6-6.35-7-8-9-9.52 11-12-12.7-14

	Albero uscita - Output shaft - Abtriebswelle						
	AU j6	A1	A2	B	B1	B2	a
AU12	12	13.5	4	15	3	21	M4x10
AU14	14	16	5	25	2	28	M5x13
AU16	16	18	5	25	2	28	M5x13

Dimensioni entrate / Input dimensions / Antriebsabmessungen

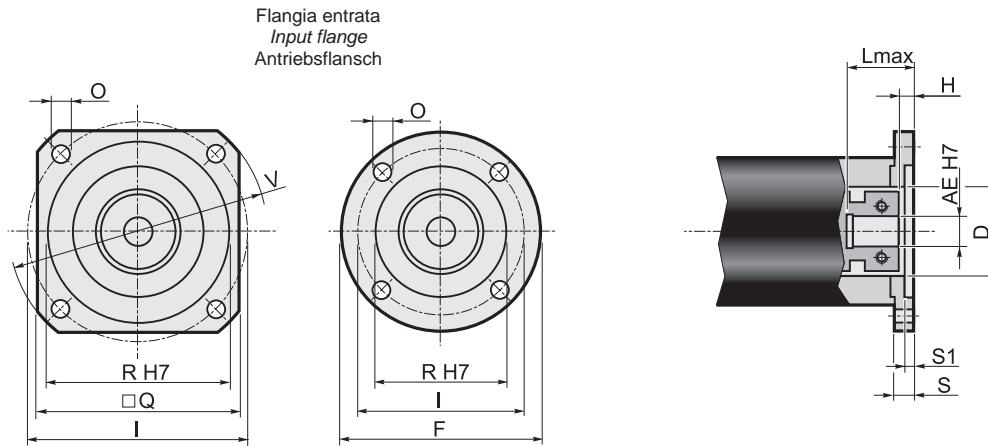

	Flange entrata / Input flange / Antriebsflansch										Albero entrata / Input shaft / Antriebswelle																					
											AE																					
											6		6.35		7		8		9		9.52		11		12		12.7		14			
	F	Q	V	I	R (H7)	O	S	S1	D		L _{max}	H	L _{max}	H	L _{max}	H	L _{max}	H	L _{max}	H	L _{max}	H	L _{max}	H	L _{max}	H	L _{max}	H	L _{max}	H		
P01*	60	=	=	43.82	22	4.5	10	3	22		34	3.5	34	3.5	34	3.5	25	5.5	25	5.5	34	5.5	25	5.5	34	5.5	34	5.5	34	5.5	34	5.5
P02*	=	60	80	66.67	38.1	5.5	10	3	32		34	3.5	34	3.5	34	3.5	25	5.5	25	5.5	34	5.5	25	5.5	34	5.5	34	5.5	34	5.5	34	5.5
P03*	=	60	80	63	40	5.5	10	3.5	32		34	3.5	34	3.5	34	3.5	25	5.5	25	5.5	34	5.5	25	5.5	34	5.5	34	5.5	34	5.5	34	5.5
P04	=	70	90	75	60	6.5	10.5	3.5	32		34.5	4	34.5	4	34.5	4	25.5	6	25.5	6	34.5	6	25.5	6	34.5	6	34.5	6	34.5	6	34.5	6
P05	105	=	=	85	70	6.5	10.5	3.5	32		34.5	4	34.5	4	34.5	4	25.5	6	25.5	6	34.5	6	25.5	6	34.5	6	34.5	6	34.5	6	34.5	6
P06	=	80	110	98.42	73.02	6	11	3.5	35		35	4.5	35	4.5	35	4.5	26	6.5	26	6.5	35	6.5	26	6.5	35	6.5	35	6.5	35	6.5	35	6.5
P07	=	95	120	100	80	6.5	11.5	4	32		35.5	5	35.5	5	35.5	5	26.5	7	26.5	7	35.5	7	26.5	7	35.5	7	35.5	7	35.5	7	35.5	7
P08	=	98	130	115	95	9	11.5	4	32		35.5	5	35.5	5	35.5	5	26.5	7	26.5	7	35.5	7	26.5	7	35.5	7	35.5	7	35.5	7	35.5	7
P09	=	116	160	130	110	9	12	4.5	32		36	5.5	36	5.5	36	5.5	27	7.5	27	7.5	36	7.5	27	7.5	36	7.5	36	7.5	36	7.5	36	7.5
P10*	60	=	=	39	26	4.5	10	3	26		34	3.5	34	3.5	34	3.5	25	5.5	25	5.5	34	5.5	25	5.5	34	5.5	34	5.5	34	5.5	34	5.5
P11*	60	=	=	42	32	4.5	10	3	32		34	3.5	34	3.5	34	3.5	25	5.5	25	5.5	34	5.5	25	5.5	34	5.5	34	5.5	34	5.5	34	5.5
P12*	65	=	=	46	32	4.5	10	3.5	32		34	3.5	34	3.5	34	3.5	25	5.5	25	5.5	34	5.5	25	5.5	34	5.5	34	5.5	34	5.5	34	5.5
P13*	80	=	=	65	50	5.5	10	3.5	32		34	3.5	34	3.5	34	3.5	25	5.5	25	5.5	34	5.5	25	5.5	34	5.5	34	5.5	34	5.5	34	5.5
P14*	60	=	=	39	20	4.5	10	2.5	20		34	3.5	34	3.5	34	3.5	25	5.5	25	5.5	34	5.5	25	5.5	34	5.5	34	5.5	34	5.5	34	5.5
P15	=	75	100	90	60	5.8	12	3.5	32		36	5.5	36	5.5	36	5.5	27	7.5	27	7.5	36	7.5	27	7.5	36	7.5	36	7.5	36	7.5	36	7.5
P16*	60	=	=	45	30	3.5	14	7	30		38	7.5	38	7.5	38	7.5	29	9.5	29	9.5	38	9.5	29	9.5	38	9.5	38	9.5	38	9.5	38	9.5
P17	=	60	82	70	50	4.5	16.5	8	32		40.5	10	40.5	10	40.5	10	31.5	12	31.5	12	40.5	12	31.5	12	40.5	12	40.5	12	40.5	12	40.5	12
P18	=	60	80	60	50	M4	10.5	3.5	32		34.5	4	34.5	4	34.5	4	25.5	6	25.5	6	34.5	6	25.5	6	34.5	6	34.5	6	34.5	6	34.5	6
P19*	60	=	=	36	25	4.5	10	3	25		34	3.5	34	3.5	34	3.5	25	5.5	25	5.5	34	5.5	25	5.5	34	5.5	34	5.5	34	5.5	34	5.5
P20	=	60	82	70	50	5.5	10.5	3.5	32		34.5	4	34.5	4	34.5	4	25.5	6	25.5	6	34.5	6	25.5	6	34.5	6	34.5	6	34.5	6	34.5	6
P21*	60	=	=	46	30	4.5	10	3	30		34	3.5	34	3.5	34	3.5	25	5.5	25	5.5	34	5.5	25	5.5	34	5.5	34	5.5	34	5.5	34	5.5
P22	=	60	80	70.71	36	4.5	10	2	32		34	3.5	34	3.5	34	3.5	25	5.5	25	5.5	34	5.5	25	5.5	34	5.5	34	5.5	34	5.5	34	5.5
P23	=	62	85	70	50	5.5	15.5	3.5	32		39.5	9	39.5	9	39.5	9	30.5	11	30.5	11	39.5	11	30.5	11	39.5	11	39.5	11	39.5	11	39.5	11
P24	=	75	100	90	70	5.8	12	3.5	32		36	5.5	36	5.5	36	5.5	27	7.5	27	7.5	36	7.5	27	7.5	36	7.5	36	7.5	36	7.5	36	7.5
P25	=	70	95	85	55	5.8	12	3.5	32		36	5.5	36	5.5	36	5.5	27	7.5	27	7.5	36	7.5	27	7.5	36	7.5	36	7.5	36	7.5	36	7.5
P26*	=	60	80	65.5	34	5.5	10	3.5	33		34	3.5	34	3.5	34	3.5	25	5.5	25	5.5	34	5.5	25	5.5	34	5.5	34	5.5	34	5.5	34	5.5
P27	=	80	110	95	50	6.5	12	3.5	32		36	5.5	36	5.5	36	5.5	27	7.5	27	7.5	36	7.5	27	7.5	36	7.5	36	7.5	36	7.5	36	7.5
P28	=	60	80	66.67	38.1	M4	9	2.5	32		33	2.5	33	2.5	33	2.5	24	4.5	24	4.5	33	4.5	24	4.5	33	4.5	33	4.5	33	4.5	33	4.5
P29	60	=	=	45	30	M3	11	4	32		35	4.5	35	4.5	35	4.5	26	6.5	26	6.5	35	6.5	26	6.5	35	6.5	35	6.5	35	6.5	35	6.5
P30	=	70	95	85	60	5.8	12	3.5	32		36	5.5	36	5.5	36	5.5	27	7.5	27	7.5	36	7.5	27	7.5	36	7.5	36	7.5	36	7.5	36	7.5
P31	=	62	85	70	50	M4	11	3.5	32		35	4.5	35	4.5	35	4.5	26	6.5	26	6.5	35	6.5	26	6.5	35	6.5	35	6.5	35	6.5	35	6.5
P32	=	60	80	65	40	M5	10	3.5	32		34	3.5	34	3.5	34	3.5	25	5.5	25	5.5	34	5.5	25	5.5	34	5.5	34	5.5	34	5.5	34	5.5
P33	=	85	115	99	60	5.5	11	3.5	32		35	4.5	35	4.5	35	4.5	26	6.5	26	6.5	35	6.5	26	6.5	35	6.5	35	6.5	35	6.5	35	6.5
P34	=	65	87	73.54	40	M4	10	3.5	32		34	3.5	34	3.5	34	3.5	25	5.5	25	5.5	34	5.5	25	5.5	34	5.5	34	5.5	34	5.5	34	5.5
P35	=	60	80	70.71	36	M4	14	2	32		38	7.5	38	7.5	38	7.5	29	9.5	29	9.5	38	9.5	29	9.5	38	9.5	38	9.5	38	9.5	38	9.5
P36	=	85	115	98.42	73.02	6	15	3.5	35		39	8.5	39	8.5	39	8.5	30	10.5	30	10.5	39	10.5	30	10.5	39	10.5	39	10.5	39	10.5	39	10.5
P37	=	95	120	100	80	6.5	16.5	5	32		40.5	10	40.5	10	40.5	10	31.5	12	31.5	12	40.5	12	31.5	12	40.5	12	40.5	12	40.5	12	40.5	12
P38	60	=	=	48	30	M3	11	7	32		35	4.5	35	4.5	35	4.5	26	6.5	26	6.5	35	6.5	26	6.5	35	6.5	35	6.5	35	6.5	35	6.5

* Per assemblare il motore è necessario smontare la flangia dal riduttore (vedere schema di montaggio 2 a pag. 25).

* Before the mounting of the motor it is necessary to remove the flange from the gearbox (see structural arrangement 2 at the top of the page 25).

* Vor dem Einbauen des Motors soll die Getriebeflange abmontiert werden (siehe Bauanleitung 2 auf Seite 25).

1.9 Dati tecnici

1.9 Technical data

1.9 Technische Daten

Stadi Steps Stufenzahl	1				2								3									
i	3	4	5	6	9	12	16	20	24	30	36	27	36	48	64	80	100	120	144	180	216	
n_{1 nom}	4000				4500								5000									
n_{1 max}	6000																					
T_{2N}	90	110	90	75	100	115	115	115	115	85	75	100	120	120	120	120	120	120	120	120	95	80
T_{2A}	145	170	130	120	160	180	180	180	180	140	130	160	190	190	190	190	190	190	190	190	150	130
T_{2S}	290	340	260	240	320	360	360	360	360	280	260	320	380	380	380	380	380	380	380	380	300	260
J	Vedi pag. 14 / See page 14 / Siehe auf Seite 14																					
LpA	< 70																					
R_d	0.96				0.93								0.91									
L_h	20000																					
F_{R2}	2100																					
F_{A2}	1050																					
R_t	11																					
α_{max}	4'				6'								8'									
Kg	2.7				3.5								4.3									

i	Rapporto di riduzione nominale	<i>Nominal ratio</i>	Nenn-Untersetzungsverhältnis
n_{1 nom}	Velocità nominale in entrata [min ⁻¹]	<i>Nominal input speed [min⁻¹]</i>	Nenn-Eingangsdrehzahl [min ⁻¹]
n_{1 max}	Velocità massima in entrata [min ⁻¹]	<i>Maximum input speed [min⁻¹]</i>	Maximale Eingangsdrehzahl [min ⁻¹]
T_{2N}	Coppia nominale intermittente in uscita [Nm]	<i>Rated intermittent output torque [Nm]</i>	Nenn-Abtriebsmoment (im Aussetzbetrieb)[Nm]
T_{2A}	Coppia massima di accelerazione in uscita [Nm]	<i>Maximum acceleration output torque [Nm]</i>	Maximales Beschleunigungsmoment am Abtrieb [Nm]
T_{2S}	Coppia massima di emergenza in uscita [Nm]	<i>Maximum emergency output torque [Nm]</i>	Maximale Überlast am Abtrieb [Nm]
LpA	Livello di rumorosità dB(A) a 3000 min ⁻¹	<i>Noise level dB(A) at 3000 min⁻¹</i>	Geräuschpegel dB(A) bei 3000 min ⁻¹
R_d	Rendimento dinamico	<i>Dynamic efficiency</i>	Dynamischer Wirkungsgrad
L_h	Durata cuscinetti [h]	<i>Bearing life [h]</i>	Lebensdauer der Lager [h]
F_{R2}	Carico radiale nominale in uscita [N] a 300min ⁻¹	<i>Rated output radial load [N] at 300min⁻¹</i>	Nenn-Radiallast an der Abtriebswelle bei 300min ⁻¹
F_{A2}	Carico assiale in uscita [N] a 300min ⁻¹	<i>Output axial load [N] at 300min⁻¹</i>	Axiallast an der Abtriebswelle bei 300min ⁻¹
R_t	Rigidità torsionale [Nm / arcmin]	<i>Torsional rigidity [Nm / arcmin]</i>	Drehfestigkeit [Nm / arcmin]
α_{max}	Gioco angolare massimo [arcmin]	<i>Maximum backlash [arcmin]</i>	Maximale Winkelspiel [arcmin]
J	Momento d'inerzia [kg.cm ²]	<i>Moment of inertia [kg.cm²]</i>	Trägheitsmoment [kg.cm ²]

1.10 Dimensioni

1.10 Dimensions

1.10 Abmessungen

Dimensioni generali e uscite / General and output dimensions / General-und Abtriebsabmessungen

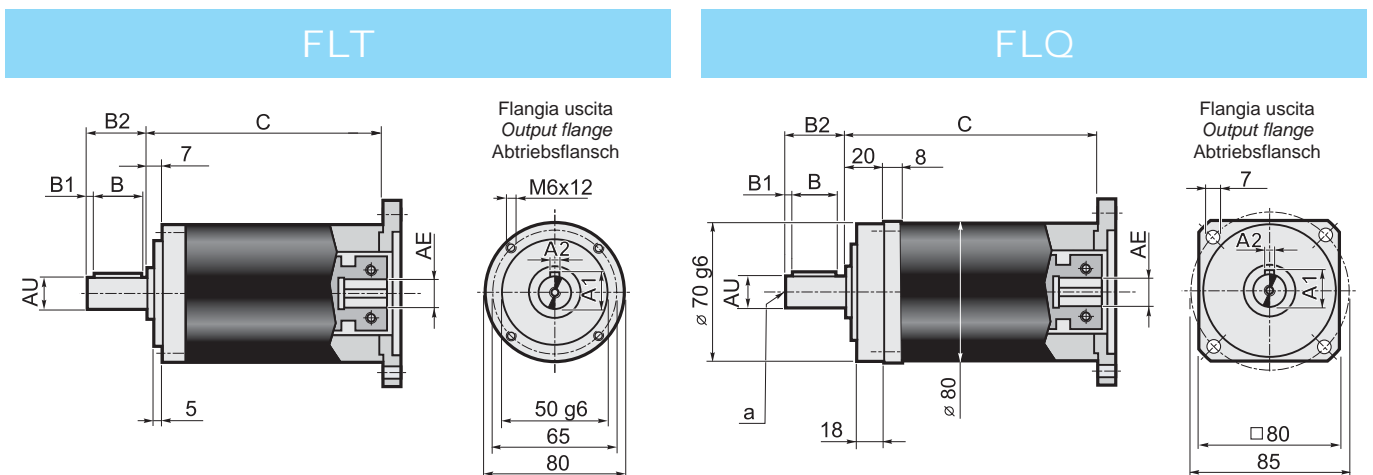

Stadi / Steps / Stufenzahl	1	2	3	
C	102	127	152.5	AE= 9-9.52-11-12.7 14-15.87-16-19

	Albero uscita - Output shaft - Abtriebswelle						
	AU j6	A1	A2	B	B1	B2	a
AU19	19	21.5	6	30	3	36	M6x16
AU22	22	24.5	6	30	3	36	M6x16

Dimensioni entrate / Input dimensions / Antriebsabmessungen

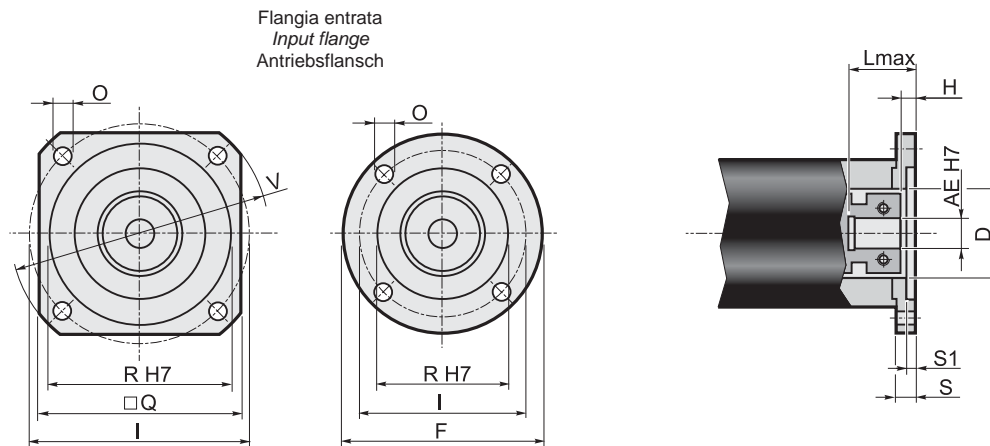

	Flange entrata / Input flange / Antriebsflansch									Albero entrata / Input shaft / Antriebswelle																	
										AE																	
	F	Q	V	I	R (H7)	O	S	S1	D	9		9.525		11		12		12.7		14		15.87		16		19	
									L _{max}	H	L _{max}	H	L _{max}	H	L _{max}	H	L _{max}	H	L _{max}	H	L _{max}	H	L _{max}	H	L _{max}	H	
P01*	80	=	=	66.67	38.1	5.5	12	3	38.1	41	3.5	41	6	26	6	41	6	41	6	41	6	41	6	41	6	41	6
P02	=	106.5	140	125.72	55.52	7	11	3	45	40	2.5	40	5	25	5	40	5	40	5	40	5	40	5	40	5	40	5
P03*	=	80	90	75	60	5.5	12	3.5	45	41	3.5	41	6	26	6	41	6	41	6	41	6	41	6	41	6	41	6
P04*	105	=	=	85	70	6.5	12	3.5	45	41	3.5	41	6	26	6	41	6	41	6	41	6	41	6	41	6	41	6
P05	=	82.5	110	98.425	73.02	6.5	12	3	45	41	3.5	41	6	26	6	41	6	41	6	41	6	41	6	41	6	41	6
P06	=	90	120	100	80	6.5	13	4	45	42	4.5	42	7	27	7	42	7	42	7	42	7	42	7	42	7	42	7
P07	=	100	135	115	95	8.5	13	4.5	45	42	4.5	42	7	27	7	42	7	42	7	42	7	42	7	42	7	42	7
P08	=	116	160	130	110	9	13	4.5	45	42	4.5	42	7	27	7	42	7	42	7	42	7	42	7	42	7	42	7
P09*	80	=	=	39	26	4.5	12	4	26	41	3.5	41	6	26	6	41	6	41	6	41	6	41	6	41	6	41	6
P10*	80	=	=	65	50	5.5	12	3.5	45	41	3.5	41	6	26	6	41	6	41	6	41	6	41	6	41	6	41	6
P11	=	150	182	166	115	9	32	11	50x14	61	23.5	61	26	46	26	61	26	61	26	61	26	61	26	61	26	61	26
P12*	=	80	105	90	70	6.5	12	3.5	32	41	3.5	41	6	26	6	41	6	41	6	41	6	41	6	41	6	41	6
P14*	105	=	=	90	70	6	19	9	32	48	10.5	48	13	33	13	48	13	48	13	48	13	48	13	48	13	48	13
P15*	80	=	=	70	50	4.5	17	8	45	46	8.5	46	11	31	11	46	11	46	11	46	11	46	11	46	11	46	11
P16	=	142	190	165	130	11	13	4.5	45	42	4.5	42	7	27	7	42	7	42	7	42	7	42	7	42	7	42	7
P17*	80	=	=	63	40	5.5	12	3.5	40	41	3.5	41	6	26	6	41	6	41	6	41	6	41	6	41	6	41	6
P18	=	130	170	145	110	M8	31	7	32	60	22.5	60	25	45	25	60	25	60	25	60	25	60	25	60	25	60	25
P19*	=	80	105	90	60	6.5	12	3.5	32	41	3.5	41	6	26	6	41	6	41	6	41	6	41	6	41	6	41	6
P20*	=	80	105	85	55	5.5	12	3.5	36	41	3.5	41	6	26	6	41	6	41	6	41	6	41	6	41	6	41	6
P21	=	80	110	95	50	M6	12	3.5	45	41	3.5	41	6	26	6	41	6	41	6	41	6	41	6	41	6	41	6
P22	80	=	=	70	50	M4	12	4	45	41	3.5	41	6	26	6	41	6	41	6	41	6	41	6	41	6	41	6
P23	=	80	90	75	60	M5	12	3.5	45	41	3.5	41	6	26	6	41	6	41	6	41	6	41	6	41	6	41	6
P24	80	=	=	46	30	M4	12	4	30	41	3.5	41	6	26	6	41	6	41	6	41	6	41	6	41	6	41	6
P26	80	=	=	65	40	M5	12	3.5	40	41	3.5	41	6	26	6	41	6	41	6	41	6	41	6	41	6	41	3.5
P27	=	80	110	82.02	36.8	M6	14	10	36.8	43	5.5	43	8	28	8	43	8	43	8	43	8	43	8	43	8	43	5.5
P28	=	90	120	100	80	6.5	28	4	45	57	19.5	57	22	42	22	57	22	57	22	57	22	57	22	57	22	57	22
P29*	80	=	=	66.67	50	5.5	12	3	45	41	3.5	41	6	26	6	41	6	41	6	41	6	41	6	41	6	41	6
P30	=	115	155	130	80	9	13	4	45	42	4.5	42	7	27	7	42	7	42	7	42	7	42	7	42	7	42	7
P31*	=	80	105	56	44	M6	14	10	36.8	43	5.5	43	8	28	8	43	8	43	8	43	8	43	8	43	8	43	8
P32	=	80	105	90	70	M6	12	3.5	32	41	3.5	41	6	26	6	41	6	41	6	41	6	41	6	41	6	41	6
P33	=	130	165	145	110	9	13	4.5	45	42	4.5	42	7	27	7	42	7	42	7	42	7	42	7	42	7	42	7
P34	=	90	120	100	80	M6	19	5	45	48	10.5	48	13	33	13	48	13	48	13	48	13	48	13	48	13	48	13
P36	=	100	135	115	95	M8	25	4.5	45	54	16.5	54	19	39	19	54	19	54	19	54	19	54	19	54	19	54	19
P37	=	85	115	98.99	60	M6	12	3.5	32	41	3.5	41	6	26	6	41	6	41	6	41	6	41	6	41	6	41	6

* Per assemblare il motore è necessario smontare la flangia dal riduttore (vedere schema di montaggio 2 a pag. 25).

* Before the mounting of the motor it is necessary to remove the flange from the gearbox (see structural arrangement 2 at the top of the page 25).

* Vor dem Einbauen des Motors soll die Getriebeflange abmontiert werden (siehe Bauanleitung 2 auf Seite 25).

Stadi Steps Stufenzahl	1				2								3									
i	3	4	5	7	9	12	16	20	28	35	49	36	48	64	80	100	140	196	245	343		
n₁ nom	3000				3500								4000									
n₁ max	5000																					
T_{2N}	220	230	200	160	250	260	260	260	260	230	180	280	280	280	280	280	280	280	250	200		
T_{2A}	350	370	320	300	400	420	420	420	420	370	350	450	450	450	450	450	450	450	400	370		
T_{2S}	700	750	650	600	800	850	850	850	850	750	700	900	900	900	900	900	900	900	800	750		
J	Vedi pag. 15 / See page 15 / Siehe auf Seite 15																					
LpA	< 70																					
R_d	0.96				0.93								0.91									
L_h	20000																					
F_{R2}	3700																					
F_{A2}	1850																					
R_t	32																					
α_{max}	4'				6'								8'									
Kg	7.2				9.3								11.4									

i	Rapporto di riduzione nominale	<i>Nominal ratio</i>	Nenn-Untersetzungsverhältnis
n₁ nom	Velocità nominale in entrata [min ⁻¹]	<i>Nominal input speed [min⁻¹]</i>	Nenn-Eingangsdrehzahl [min ⁻¹]
n₁ max	Velocità massima in entrata [min ⁻¹]	<i>Maximum input speed [min⁻¹]</i>	Maximale Eingangsdrehzahl [min ⁻¹]
T_{2N}	Coppia nominale intermittente in uscita [Nm]	<i>Rated intermittent output torque [Nm]</i>	Nenn-Abtriebsmoment (im Aussetzbetrieb)[Nm]
T_{2A}	Coppia massima di accelerazione in uscita [Nm]	<i>Maximum acceleration output torque [Nm]</i>	Maximales Beschleunigungsmoment am Abtrieb [Nm]
T_{2S}	Coppia massima di emergenza in uscita [Nm]	<i>Maximum emergency output torque [Nm]</i>	Maximale Überlast am Abtrieb [Nm]
LpA	Livello di rumorosità dB(A) a 3000 min ⁻¹	<i>Noise level dB(A) at 3000 min⁻¹</i>	Geräuschpegel dB(A) bei 3000 min ⁻¹
R_d	Rendimento dinamico	<i>Dynamic efficiency</i>	Dynamischer Wirkungsgrad
L_h	Durata cuscinetti [h]	<i>Bearing life [h]</i>	Lebensdauer der Lager [h]
F_{R2}	Carico radiale nominale in uscita [N] a 300min ⁻¹	<i>Rated output radial load [N] at 300min⁻¹</i>	Nenn-Radiallast an der Abtriebswelle bei 300min ⁻¹
F_{A2}	Carico assiale in uscita [N] a 300min ⁻¹	<i>Output axial load [N] at 300min⁻¹</i>	Axiallast an der Abtriebswelle bei 300min ⁻¹
R_t	Rigidità torsionale [Nm / arcmin]	<i>Torsional rigidity [Nm / arcmin]</i>	Drehfestigkeit [Nm / arcmin]
α_{max}	Gioco angolare massimo [arcmin]	<i>Maximum backlash [arcmin]</i>	Maximale Winkelspiel [arcmin]
J	Momento d'inertzia [kg.cm ²]	<i>Moment of inertia [kg.cm²]</i>	Trägheitsmoment [kg.cm ²]

1.10 Dimensioni

1.10 Dimensions

1.10 Abmessungen

Dimensioni generali e uscite / General and output dimensions / General-und Abtriebsabmessungen

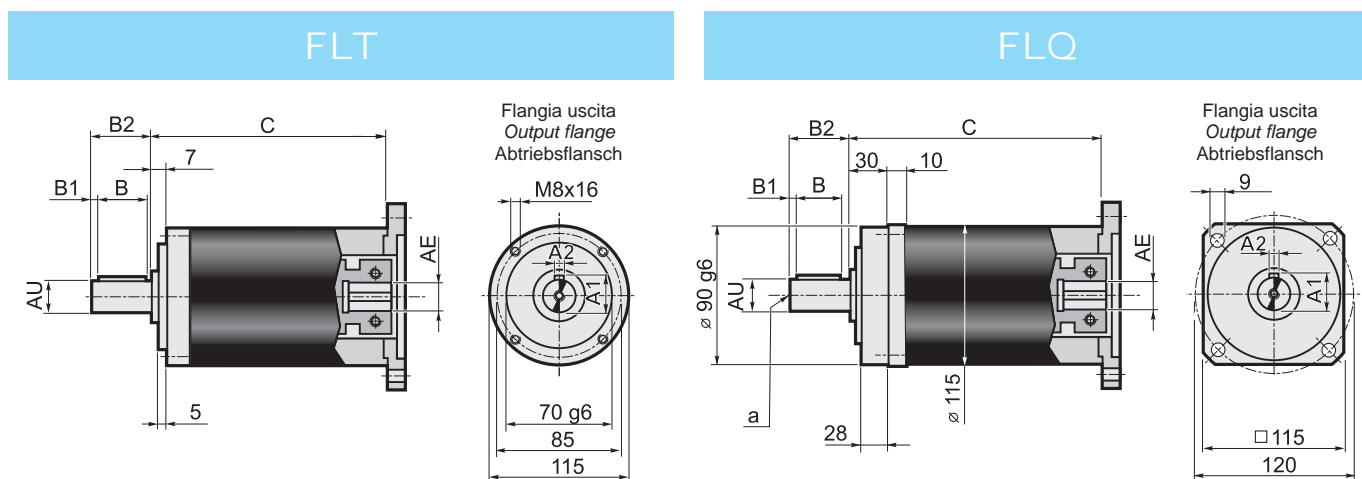

Stadi / Steps / Stufenzahl	1	2	3	
C	126	158.4	191	AE= 12.7-14-15.87-16-19
	145	177	210	AE= 22-24-25-28

	Albero uscita - Output shaft - Abtriebswelle						
	AU j6	A1	A2	B	B1	B2	a
AU25	25	28	8	40	5	50	M8x20
AU32	32	35	10	50	4	58	M10x25

Dimensioni entrate / Input dimensions / Antriebsabmessungen

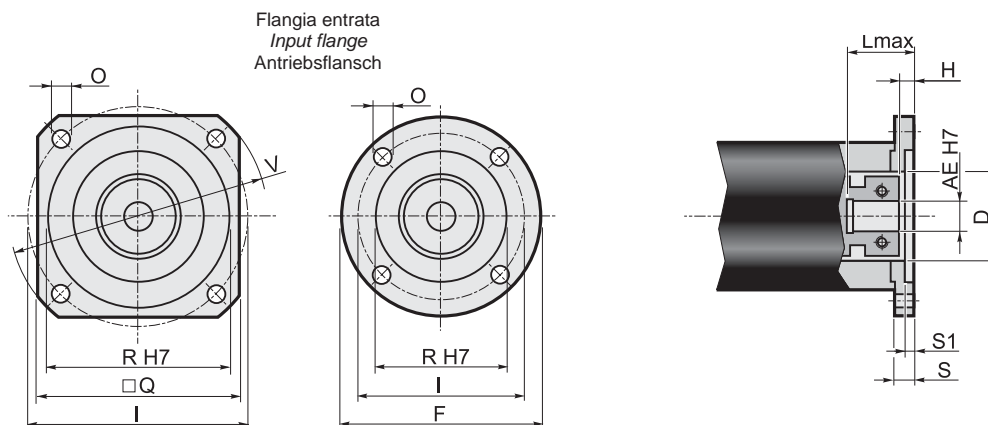

Flange entrata / Input flange / Antriebsflansch		Albero entrata / Input shaft / Antriebswelle																									
		AE																									
		12.7		14		15.87		16		19		22		24		25		28									
F	Q	V	I	R (H7)	O	S	S1	D	L _{max}	H	L _{max}	H	L _{max}	H	L _{max}	H	L _{max}	H	L _{max}	H	L _{max}	H	L _{max}	H			
P01*	=	115	140	125.72	55.52	6.5	13	3	55.52	43	6	35	6	43	6	43	6	43	6	43	6	62	6	62	6	62	6
P02*	115	=	=	75	60	5.5	13	3.5	60	43	6	35	6	43	6	43	6	43	6	43	6	62	6	62	6	62	6
P03*	115	=	=	85	70	6.5	13	3.5	60	43	6	35	6	43	6	43	6	43	6	43	6	62	6	62	6	62	6
P04*	115	=	=	98.42	73.02	6.5	13	3	60	43	6	35	6	43	6	43	6	43	6	43	6	62	6	62	6	62	6
P05*	120	=	=	100	80	6.5	13	4	60	43	6	35	6	43	6	43	6	43	6	43	6	62	6	62	6	62	6
P06*	=	115	140	115	95	9	13	4.5	60	43	6	35	6	43	6	43	6	43	6	43	6	62	6	62	6	62	6
P07	=	115	160	130	110	8.5	13	4.5	60	43	6	35	6	43	6	43	6	43	6	43	6	62	6	62	6	62	6
P08	=	142	190	165	130	11	13	4.5	60	43	6	35	6	43	6	43	6	43	6	43	6	62	6	62	6	62	6
P09	=	192	250	215	180	13	14	4.5	60	44	7	36	7	44	7	44	7	44	7	44	7	63	7	63	7	63	7
P10*	115	=	=	65	50	6.5	13	3.5	50	43	6	35	6	43	6	43	6	43	6	43	6	62	6	62	6	62	6
P11	=	130	170	145	110	M 8	31	7	60	61	24	53	24	61	24	61	24	61	24	61	24	80	24	80	24	80	24
P12	=	130	170	145	110	M 8	17	7	60	47	10	39	10	47	10	47	10	47	10	47	10	66	10	66	10	66	10
P13	=	115	160	130	110	M 8	13	4.5	60	43	6	35	6	43	6	43	6	43	6	43	6	62	6	62	6	62	6
P14*	115	=	=	70	50	6.5	13	3.5	50	43	6	35	6	43	6	43	6	43	6	43	6	62	6	62	6	62	6
P15	115	=	=	90	70	M5	11	3.5	60	41	4	33	4	41	4	41	4	41	4	41	4	60	4	60	4	60	4
P17*	115	=	=	90	70	6.5	13	3.5	60	43	6	35	6	43	6	43	6	43	6	43	6	62	6	62	6	62	6
P18	=	115	155	130	95	8.5	13	4.5	60	43	6	35	6	43	6	43	6	43	6	43	6	62	6	62	6	62	6
P19*	115	=	=	95	50	6.5	13	3.5	50	43	6	35	6	43	6	43	6	43	6	43	6	62	6	62	6	62	6
P20	115	=	=	99	60	M6	13	4	60	43	6	35	6	43	6	43	6	43	6	43	6	62	6	62	6	62	6
P21*	130	=	=	106	82.5	12.5	26.5	15	60	56.5	19.5	48.5	17.5	56.5	19.5	56.5	19.5	56.5	19.5	56.5	19.5	75.5	19.5	75.5	19.5	75.5	19.5
P22	=	144	190	165	110	11	15	4.5	60	45	8	37	8	45	8	45	8	45	8	45	8	64	8	64	8	64	8
P23*	115	=	=	63	40	5.5	11	3.5	40	41	4	33	4	41	4	41	4	41	4	41	4	60	4	60	4	60	4
P24	120	=	=	100	80	M6	18	7	60	48	11	40	11	48	11	48	11	48	11	48	11	67	11	67	11	67	11

* Per assemblare il motore è necessario smontare la flangia dal riduttore (vedere schema di montaggio 2 a pag. 25).

* Before the mounting of the motor it is necessary to remove the flange from the gearbox (see structural arrangement 2 at the top of the page 25).

* Vor dem Einbauen des Motors soll die Getriebeflang abmontiert werden (siehe Bauanleitung 2 auf Seite 25).

Stadi Steps Stufenzahl	1				2								3									
i	3	4	5	7	9	12	16	20	28	35	49	36	48	64	80	100	140	196	245	343		
n_{1 nom}	3000				3500								4000									
n_{1 max}	5000																					
T_{2N}	430	470	410	340	500	560	560	560	560	470	370	600	600	600	600	600	600	600	500	450		
T_{2A}	700	750	650	600	800	900	900	900	900	750	700	950	950	950	950	950	950	950	800	750		
T_{2S}	1400	1500	1300	1200	1600	1800	1800	1800	1800	1500	1400	1900	1900	1900	1900	1900	1900	1900	1600	1500		
J	Vedi pag. 15 / See page 15 / Siehe auf Seite 15																					
LpA	< 70																					
R_d	0.96				0.93								0.91									
L_h	20000																					
F_{R2}	6600																					
F_{A2}	3300																					
R_t	60																					
α_{max}	4'				6'								8'									
Kg	13.0				17.0								21									

i	Rapporto di riduzione nominale	<i>Nominal ratio</i>	Nenn-Untersetzungsverhältnis
n_{1 nom}	Velocità nominale in entrata [min ⁻¹]	<i>Nominal input speed [min⁻¹]</i>	Nenn-Eingangsdrehzahl [min ⁻¹]
n_{1 max}	Velocità massima in entrata [min ⁻¹]	<i>Maximum input speed [min⁻¹]</i>	Maximale Eingangsdrehzahl [min ⁻¹]
T_{2N}	Coppia nominale intermittente in uscita [Nm]	<i>Rated intermittent output torque [Nm]</i>	Nenn-Abtriebsmoment (im Aussetzbetrieb)[Nm]
T_{2A}	Coppia massima di accelerazione in uscita [Nm]	<i>Maximum acceleration output torque [Nm]</i>	Maximales Beschleunigungsmoment am Abtrieb [Nm]
T_{2S}	Coppia massima di emergenza in uscita [Nm]	<i>Maximum emergency output torque [Nm]</i>	Maximale Überlast am Abtrieb [Nm]
LpA	Livello di rumorosità dB(A) a 3000 min ⁻¹	<i>Noise level dB(A) at 3000 min⁻¹</i>	Geräuschpegel dB(A) bei 3000 min ⁻¹
R_d	Rendimento dinamico	<i>Dynamic efficiency</i>	Dynamischer Wirkungsgrad
L_h	Durata cuscinetti [h]	<i>Bearing life [h]</i>	Lebensdauer der Lager [h]
F_{R2}	Carico radiale nominale in uscita [N] a 300min ⁻¹	<i>Rated output radial load [N] at 300min⁻¹</i>	Nenn-Radiallast an der Abtriebswelle bei 300min ⁻¹
F_{A2}	Carico assiale in uscita [N] a 300min ⁻¹	<i>Output axial load [N] at 300min⁻¹</i>	Axiallast an der Abtriebswelle bei 300min ⁻¹
R_t	Rigidità torsionale [Nm / arcmin]	<i>Torsional rigidity [Nm / arcmin]</i>	Drehfestigkeit [Nm / arcmin]
α_{max}	Gioco angolare massimo [arcmin]	<i>Maximum backlash [arcmin]</i>	Maximale Winkelspiel [arcmin]
J	Momento d'inerzia [kg.cm ²]	<i>Moment of inertia [kg.cm²]</i>	Trägheitsmoment [kg.cm ²]

1.10 Dimensioni

1.10 Dimensions

1.10 Abmessungen

Dimensioni generali e uscite / General and output dimensions / General-und Abtriebsabmessungen

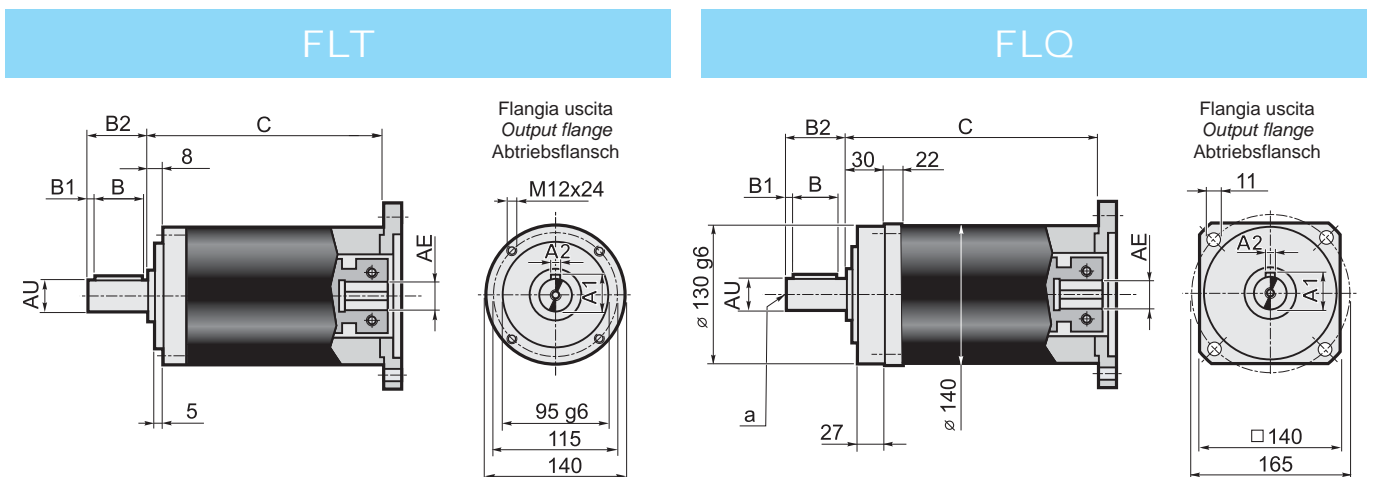

Stadi / Steps / Stufenzahl	1	2	3	
C	160	201	242	AE= 15.87-16-19-22-24
	185	226	267	AE= 28-32-35-38

	Albero uscita - Output shaft - Abtriebswelle						
	AU j6	A1	A2	B	B1	B2	a
AU38	38	41	10	70	5	80	M10x25
AU40	40	43	12	70	5	80	M10x25

Dimensioni entrate / Input dimensions / Antriebsabmessungen

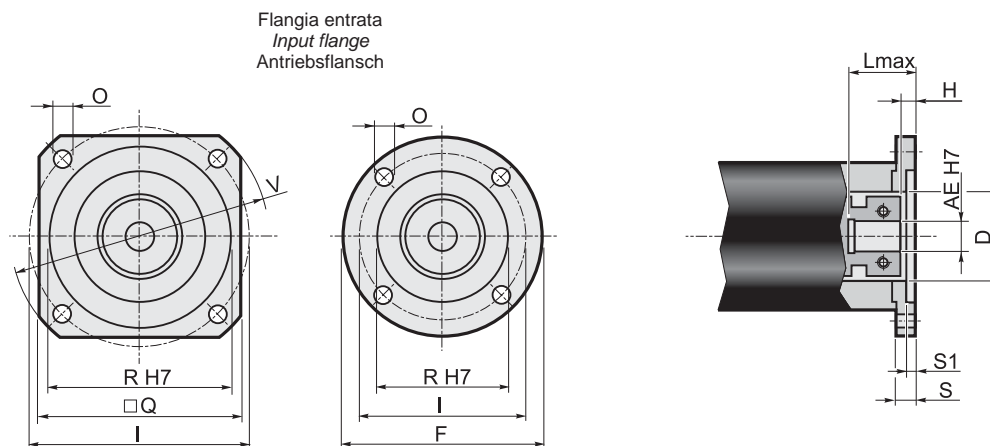

Flange entrata / Input flange / Antriebsflansch	Albero entrata / Input shaft / Antriebswelle																										
										AE																	
										15.87		16		19		22		24		28		32		35		38	
F	Q	V	I	R (H7)	O	S	S1	D	L _{max}	H	L _{max}	H	L _{max}	H	L _{max}	H	L _{max}	H	L _{max}	H	L _{max}	H	L _{max}	H			
P01*	140	=	=	125.72	55.52	6.5	15	4	55.52	57.8	6.8	57.8	6.8	42.8	6.8	57.8	6.8	57.8	6.8	82.8	7.3	82.8	7.3	82.8	7.3	82.8	7.3
P02*	140	=	=	100	80	6.5	15	4	70	57.8	6.8	57.8	6.8	42.8	6.8	57.8	6.8	57.8	6.8	82.8	7.3	82.8	7.3	82.8	7.3	82.8	7.3
P03*	140	=	=	115	95	8.5	15	4.5	70	57.8	6.8	57.8	6.8	42.8	6.8	57.8	6.8	57.8	6.8	82.8	7.3	82.8	7.3	82.8	7.3	82.8	7.3
P04*	=	140	160	130	110	8.5	15	4.5	70	57.8	6.8	57.8	6.8	42.8	6.8	57.8	6.8	57.8	6.8	82.8	7.3	82.8	7.3	82.8	7.3	82.8	7.3
P05	=	142	190	165	130	11	15	4.5	70	57.8	6.8	57.8	6.8	42.8	6.8	57.8	6.8	57.8	6.8	82.8	7.3	82.8	7.3	82.8	7.3	82.8	7.3
P06	=	190	250	215	180	13	15	4.5	70	57.8	6.8	57.8	6.8	42.8	6.8	57.8	6.8	57.8	6.8	82.8	7.3	82.8	7.3	82.8	7.3	82.8	7.3
P07	=	250	300	265	230	13	15	4.5	70	57.8	6.8	57.8	6.8	42.8	6.8	57.8	6.8	57.8	6.8	82.8	7.3	82.8	7.3	82.8	7.3	82.8	7.3
P08	=	130	165	145	110	M 8	18	7	70	60.8	9.8	60.8	9.8	45.8	9.8	60.8	9.8	60.8	9.8	85.8	10.3	85.8	10.3	85.8	10.3	85.8	10.3
P09	=	180	230	200	114.3	13.5	22	11	70	64.8	13.8	64.8	13.8	49.8	13.8	64.8	13.8	64.8	13.8	89.8	14.3	89.8	14.3	89.8	14.3	89.8	14.3
P10	=	115	150	130	95	M 8	15	4.5	70	57.8	6.8	57.8	6.8	42.8	6.8	57.8	6.8	57.8	6.8	82.8	7.3	82.8	7.3	82.8	7.3	82.8	7.3
P11	=	180	230	198	155	13.5	22	7	120x11	64.8	13.8	64.8	13.8	49.8	13.8	64.8	13.8	64.8	13.8	89.8	14.3	89.8	14.3	89.8	14.3	89.8	14.3
P12	=	220	270	235	200	13.5	15	5	70	57.8	6.8	57.8	6.8	42.8	6.8	57.8	6.8	57.8	6.8	82.8	7.3	82.8	7.3	82.8	7.3	82.8	7.3
P13	=	190	250	215	130	13	15	4.5	70	57.8	6.8	57.8	6.8	42.8	6.8	57.8	6.8	57.8	6.8	82.8	7.3	82.8	7.3	82.8	7.3	82.8	7.3
P14	=	142	190	165	110	11	15	4.5	70	57.8	6.8	57.8	6.8	42.8	6.8	57.8	6.8	57.8	6.8	82.8	7.3	82.8	7.3	82.8	7.3	82.8	7.3
P15*	150	=	=	90	70	6.5	15	4	70	57.8	6.8	57.8	6.8	42.8	6.8	57.8	6.8	57.8	6.8	82.8	7.3	82.8	7.3	82.8	7.3	82.8	7.3
P16	=	146	200	177.8	114.3	10.5	15	3.5	70	57.8	6.8	57.8	6.8	42.8	6.8	57.8	6.8	57.8	6.8	82.8	7.3	82.8	7.3	82.8	7.3	82.8	7.3

* Per assemblare il motore è necessario smontare la flangia dal riduttore (vedere **schema di montaggio 2** a pag. 25).

* Before the mounting of the motor it is necessary to remove the flange from the gearbox (see **structural arrangement 2** at the top of the page 25)

* Vor dem Einbauen des Motors soll die Getriebeflang abmontiert werden (siehe **Bauanleitung 2** auf Seite 25).