

PERFECTION IS A MASTERPIECE

# RIDUTTORI A INGRANAGGI

HELICAL AND BEVEL HELICAL GEARBOXES  
UNTERSETZUNGSGETRIEBE

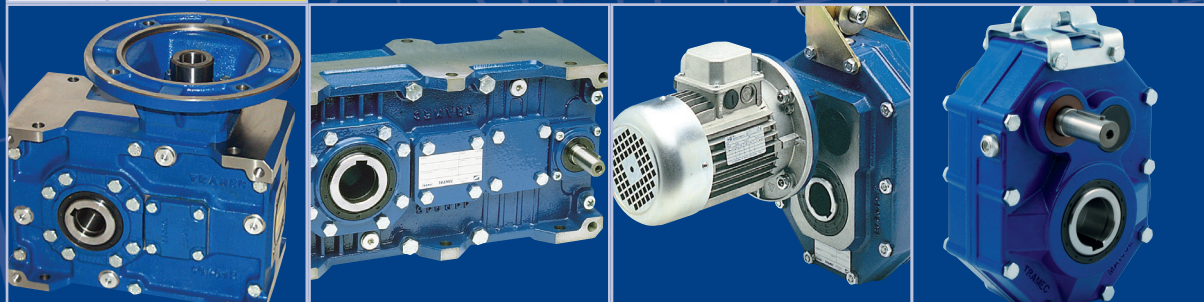

T

Z

P

M

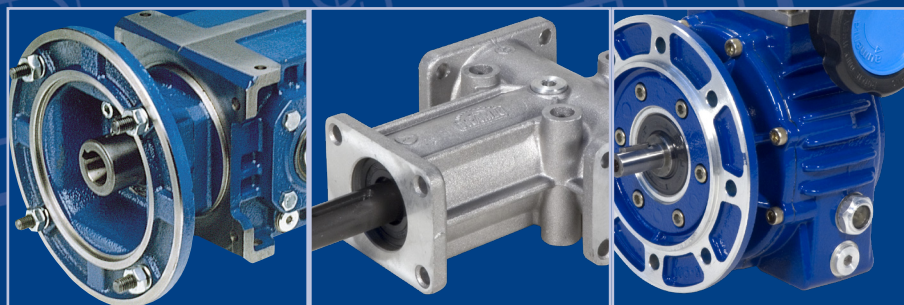

R - L

RL

N - UDL



# MADE IN ITALY

Per TRAMEC l'espressione "MADE IN ITALY" possiede un significato molto più profondo di quanto gli venga attribuito nell'uso comune. Tutti i prodotti di TRAMEC sono infatti il risultato di :

## PROGETTAZIONE E CREATIVITA' ITALIANA

Ogni riduttore della gamma TRAMEC è completamente progettato in ITALIA, nella sede principale di CALDERARA di RENO (BOLOGNA), nel cuore della cosiddetta "MOTOR VALLEY" e "PACKAGING VALLEY", un territorio dove la meccanica è da sempre protagonista. Qui gli ingegneri TRAMEC esprimono al meglio la creatività ITALIANA, avvalendosi di strumenti sempre più evoluti per progettare riduttori innovativi e personalizzabili in base a specifiche esigenze del cliente.

## PRODUZIONE E MONTAGGIO

Tutti i componenti principali dei riduttori TRAMEC vengono realizzati dalla rete produttiva della nostra Azienda, che si avvale anche dell'esperienza e delle capacità di artigiani selezionati presenti sul medesimo territorio.

Dall'assemblaggio di tali componenti, eseguito con perizia dai nostri tecnici esperti, nascono i riduttori TRAMEC. Il risultato è un prodotto di altissima qualità, come quelli descritti nel catalogo che state sfogliando.

## SERVIZIO AL CLIENTE

L'importanza che TRAMEC attribuisce ai propri clienti non si riflette solamente nel fornire un prodotto di elevata qualità, ma anche nel garantire un'assistenza PRE e POST-VENDITA all'altezza del prodotto fornito.

In questo modo, curando al massimo la qualità dei prodotti e rimanendo costantemente al fianco del Cliente, si esprime a pieno l'ITALIANITA' della nostra Azienda.

Ecco cosa significa per TRAMEC l'espressione "MADE IN ITALY".

---

At TRAMEC "MADE IN ITALY" is an expression with a much deeper meaning , as all TRAMEC products are the result of :

## ITALIAN DESIGN & CREATIVITY

TRAMEC is headquartered in CALDERARA di RENO (BOLOGNA), in the heart of Italy's famous "MOTOR VALLEY" or "PACKAGING VALLEY" where the art of performance is mastered with the science of precision.

Italian design & engineering creativity is expressed via the most advanced tools by TRAMEC engineers in the design of our standard and customized products. This creativity results in an innovative design of remarkable quality which is presented in the catalogue before you.

## PRODUCTION & ASSEMBLY

The designs of TRAMEC are brought to life through the careful hands of machinists and technicians expressing the local tradition of excellence. All major components are produced , assembled , and inspected within the TRAMEC manufacturing organization.

From this long tradition, expressing performance and precision into objects of exceptional quality , we introduce the TRAMEC'S GEARBOXES.

## CUSTOMER CARE

Everything we do, from conception to delivery, is focused upon our customers. High performance precision products made to increasingly demanding levels of quality deserve excellence before, during and after the purchase

At TRAMEC we express our Italian culture and heritage in caring for our customers throughout the process.

From everyone at TRAMEC, this is what it means to say "MADE IN ITALY".

---

Für TRAMEC hat der Begriff "MADE IN ITALY" eine sehr viel wichtigere Bedeutung als die im üblichen Gebrauch geltende. Alle Produkte von TRAMEC sind das Ergebnis von:

## ITALIENISCHER PLANUNG UND KREATIVITÄT

Alle Produkte von TRAMEC werden vollkommen in ITALIEN geplant, und zwar im Hauptsitz in CALDERARA di RENO (BO), mitten im "MOTOR VALLEY" und "PACKAGING VALLEY", dort wo die Mechanik vorherrscht. Hier wird die ITALIENISCHE Kreativität von den Ingenieuren von TRAMEC voll bei der mit stets noch fortschrittlicheren Instrumenten vorgenommenen Planung von Produkten, die auch kundenspezifisch sein können, voll zum Ausdruck gebracht. Das Ergebnis sind Produkte mit qualitativ sehr hochwertigen Merkmalen, so wie die im Katalog, den Sie gerade durchblättern.

## PRODUKTION UND MONTAGE

Alle wichtigen Komponenten der Produkte von TRAMEC sind das Ergebnis des Produktionsnetzes unseres Unternehmens, das sich auf die Erfahrung und die Fähigkeiten der Handwerker in unserem gebiet stützt.

Durch den Zusammenbau dieser Komponenten, der vollkommen von den erfahrenen und ausgezeichneten Technikern von TRAMEC ausgeführt wird, entsteht dann das Planetengetriebe MTA.

## KUNDENDIENST





Für TRAMEC wird die Wichtigkeit der Kundschaft nicht nur damit ausgedrückt, dass ein qualitativ hochwertiges Produkt geliefert wird, sondern auch durch einen KUNDENDIENST, der vor und nach dem Verkauf auf demselben Qualitätsniveau steht, wie das Produkt selbst. Auch auf diese Art, durch den stetigen Beistand dem Kunden gegenüber, wird das ITALIENISCHE Wesen ausgedrückt.

All das zusammen bedeutet für TRAMEC "MADE IN ITALY".



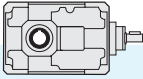
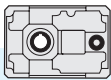

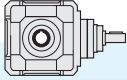
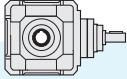
**INDICE**
**INDEX**
**INHALTSVERZEICHNIS**

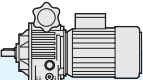
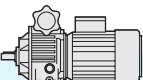
<b>1.0</b>	<b>GENERALITA'</b>	<b>GENERAL INFORMATION</b>	<b>ALLGEMEINES</b>	<b>2</b>
1.1	Unità di misura	<i>Measurement units</i>	Maßeinheiten	2
1.2	Fattore di servizio	<i>Service factor</i>	Betriebsfaktor	2
1.3	Selezione	<i>Selection</i>	Wahl	4
1.4	Potenza termica	<i>Thermal power</i>	Thermische Leistung	5
1.5	Verifica del dispositivo antiritorno	<i>Check out of the backstop device</i>	Prüfung der Rücklauf Sperre	6
1.6	Lubrificazione	<i>Lubrication</i>	Ölschmierung	8
1.7	Installazione	<i>Installation</i>	Einbau	9
1.8	Rodaggio	<i>Running-in</i>	Einfahren	10
1.9	Manutenzione	<i>Maintenance</i>	Wartung	10
				
<b>2.0</b>	<b>RIDUTTORI AD ASSI ORTOGONALI T</b>	<b>BEVEL HELICAL GEARBOX T</b>	<b>KEGELSTIRNRADGETRIEBE T</b>	<b>11</b>
				
<b>3.0</b>	<b>RIDUTTORI AD ASSI PARALLELI Z</b>	<b>PARALLEL SHAFT GEARBOX Z</b>	<b>PARALLELENGETRIEBE Z</b>	<b>45</b>
				
<b>4.0</b>	<b>RIDUTTORI PENDOLARI P</b>	<b>SHAFT-MOUNTED GEARBOX P</b>	<b>AUFSTECKGETRIEBE P</b>	<b>69</b>
				
<b>5.0</b>	<b>RIDUTTORI PENDOLARI M</b>	<b>SHAFT-MOUNTED GEARBOX M</b>	<b>AUFSTECKGETRIEBE M</b>	<b>85</b>
				
<b>6.0</b>	<b>RINVII ANGOLARI R</b>	<b>RIGHT ANGLE GEARBOX R</b>	<b>WINKELGETRIEBE R</b>	<b>95</b>
				
<b>7.0</b>	<b>RINVII ANGOLARI L</b>	<b>RIGHT ANGLE GEARBOX L</b>	<b>WINKELGETRIEBE L</b>	<b>111</b>
				
<b>8.0</b>	<b>RINVII ANGOLARI RL</b>	<b>RIGHT ANGLE GEARBOX RL</b>	<b>WINKELGETRIEBE RL</b>	<b>127</b>
				
<b>9.0</b>	<b>VARIATORI N</b>	<b>VARIATORS N</b>	<b>VERSTELLGETRIEBE N</b>	<b>135</b>
				
<b>10.0</b>	<b>VARIATORI UDL</b>	<b>VARIATORS UDL</b>	<b>VERSTELLGETRIEBE UDL</b>	<b>147</b>
<b>11.0</b>	<b>MOTORI ELETTRICI</b>	<b>ELECTRIC MOTORS</b>	<b>ELEKTROMOTOREN</b>	<b>153</b>
<b>12.0</b>	<b>CONDIZIONI GENERALI DI VENDITA</b>	<b>TERM AND CONDITIONS OF SALE</b>	<b>ALLGEMEINE VERKAUFSBEDINGUNGEN</b>	<b>157</b>

**1.0 GENERALITA'**
**1.0 GENERAL INFORMATION**
**1.0 ALLGEMEINES**
**1.1 Unità di misura**
**1.1 Measurement units**
**1.1 Maßeinheiten**

Tab. 1

SIMBOLO SYMBOL SYMBOLE	DEFINIZIONE	DEFINITION	BEZEICHNUNG	UNITA' DI MISURA MEASUREMENT UNIT MAßEINHEIT
<b>Fr</b> 1-2	Carico Radiale	<i>Radial load</i>	Radialbelastung	<b>N</b>
<b>Fa</b> 1-2	Carico Assiale	<i>Axial load</i>	Axialbelastung	<b>N</b>
	Dimensioni	<i>Dimensions</i>	Abmessungen	<b>mm</b>
<b>FS</b>	Fattore di servizio	<i>Service factor</i>	Betriebsfaktor	
<b>kg</b>	Massa	<i>Mass</i>	Masse	<b>kg</b>
<b>T<sub>2M</sub></b>	Momento torcente riduttore	<i>Gearbox torque</i>	Getriebe Drehmoment	<b>Nm</b>
<b>T<sub>2</sub></b>	Momento torcente motorid.	<i>Gearmotor torque</i>	Getriebemotor Drehmoment	<b>Nm</b>
<b>P</b>	Potenza motore	<i>Motor power</i>	Motor Leistung	<b>kW</b>
<b>Pc</b>	Potenza corretta	<i>Corrected power</i>	Verbesserte Leistung	<b>kW</b>
<b>P1</b>	Potenza motoriduttore	<i>Gearmotor power</i>	Getriebemotor Leistung	<b>kW</b>
<b>P<sub>10</sub></b>	Potenza termica	<i>Thermal power</i>	Thermische Leistung	<b>kW</b>
<b>P'</b>	Potenza richiesta in uscita	<i>Output power</i>	Erforderliche Abtriebsleistung	<b>kW</b>
<b>RD</b>	Rendimento dinamico	<i>Dynamic efficiency</i>	Dynamischer Wirkungsgrad	
<b>in</b>	Rapp. di trasm. nominale	<i>Rated reduction ratio</i>	Nennuntersetzung	
<b>ir</b>	Rapporto di trasmissione reale	<i>Actual reduction ratio</i>	Reelle Untersetzung	
<b>n<sub>1</sub></b>	Velocità albero entrata	<i>Input speed</i>	Antriebsdrehzahl	<b>min<sup>-1</sup></b>
<b>n<sub>2</sub></b>	Velocità albero uscita	<i>Output speed</i>	Abtriebsdrehzahl	<b>min<sup>-1</sup></b>
<b>Tc</b>	Temperatura ambiente	<i>Ambient temperature</i>	Umgebungstemperatur	<b>°C</b>
<b>η</b>	Rendimento	<i>Efficiency</i>	Wirkungsgrad	
<b>IEC</b>	Motori accoppiabili	<i>Motor options</i>	Passende Motoren	

**1.2 Fattore di servizio**
**1.2 Service factor**
**1.2 Betriebsfaktor**

Il fattore di servizio **FS** permette di qualificare, in prima approssimazione, la tipologia dell'applicazione tenendo conto della natura del carico (A, B, C), della durata di funzionamento h/gg (ore giornaliere) e del numero di avviamenti/ora. Il coefficiente così trovato dovrà essere uguale o inferiore al fattore di servizio del riduttore **F<sub>s</sub>'** dato dal rapporto fra la coppia nominale del riduttore **T<sub>2M</sub>** indicata a catalogo e la coppia **T<sub>2</sub>'** richiesta dall'applicazione.

*Service factor **FS** enables approximate qualification of the type of application, taking into account type of load (A,B,C), length of operation h/d (hours/day) and the number of starts-up/hour. The coefficient thus calculated must be equal to or lower than the gear unit service factor **F<sub>s</sub>'** which equals the ratio between **T<sub>2M</sub>** (gear unit rated torque reported in the catalogue) and **T<sub>2</sub>'** (torque required by the application).*

Der **FS** Betriebsfaktor ermöglicht die annähernde Bestimmung der Anwendungsart. Dabei werden Art der Last (A, B, C), Betriebsstunden pro Tag (S/T) und Anzahl der Starts pro Stunde berücksichtigt. Der so ermittelte Koeffizient sollte dem Betriebsfaktor **F<sub>s</sub>'**, der sich aus dem Verhältnis zwischen Nenndrehmoment des Getriebes **T<sub>2M</sub>** (s. Katalog) und dem für die Anwendung erforderlichen Drehmoment **T<sub>2</sub>'** ergibt, entweder entsprechen oder niedriger liegen.

$$FS' = \frac{T_{2M}}{T_2'} > FS$$

I valori di **FS** indicati nella tab. 2, sono relativi all'azionamento con motore elettrico; se utilizzato un motore a scoppio, si dovrà tenere conto di un fattore di moltiplicazione 1.3 se a più cilindri e 1.5 se monocilindro. Se il motore elettrico applicato è autofrenante, considerare un numero di avviamenti doppio di quello effettivamente richiesto.

***FS** values reported in table 2 refer to a drive unit equipped with an electric motor. If an internal combustion engine is used, a multiplication factor of 1.3 must be applied for a several-cylinder engine, 1.5 for a single-cylinder engine. If the electric motor is self-braking, consider twice the number of starts-up than those actually required.*

Die **FS** Werte, die in Tabelle 2 angegeben werden, beziehen sich auf den Antrieb mit Elektromotor; falls ein Explosionsmotor verwendet wird, ist ein Multiplikationsfaktor von 1.3 für Mehrzylindermotor und von 1.5 für Einzylindermotor zu berücksichtigen. Falls der verwendete Elektromotor ein Bremsmotor ist, so ist die Zahl der tatsächlich erforderlichen Startvorgänge doppelt zu zählen.

Tab. 2

Classe di carico <i>Load class</i> Lastklasse	h/gg <i>h/d</i> St./Tag	N. AVVIAMENTI/ORA / N. START-UP/HOUR / ANZAHL DER STARTVORGÄNGE PRO STUNDE								
		2	4	8	16	32	63	125	250	500
<b>A</b>	4	0.8	0.8	0.9	0.9	1.0	1.1	1.1	1.2	1.2
	8	1.0	1.0	1.1	1.1	1.3	1.3	1.3	1.3	1.3
	16	1.3	1.3	1.3	1.3	1.5	1.5	1.5	1.5	1.5
	24	1.5	1.5	1.5	1.5	1.8	1.8	1.8	1.8	1.8
APPLICAZIONI / APPLICATIONS / ANWENDUNGEN										
Agitatori per liquidi puri Alimentatori per fornaci Alimentatori a disco Filtri di lavaggio con aria Generatori Pompe centrifughe Trasportatori con carico uniforme			<i>Pure liquid agitators</i> <i>Furnace feeders</i> <i>Disc feeders</i> <i>Air laundry filters</i> <i>Generators</i> <i>Centrifugal pumps</i> <i>Uniform load conveyors</i>			Rührwerke für reine Flüssigkeiten Beschickungsvorrichtungen für Brennöfen Telleraufgeber Spülluftfilter Generatoren Kreiselpumpen Förderer mit gleichmäßig verteilter Last				

Classe di carico <i>Load class</i> Lastklasse	h/gg <i>h/d</i> St./Tag	N. AVVIAMENTI/ORA / N. START-UP/HOUR / ANZAHL DER STARTVORGÄNGE PRO STUNDE								
		2	4	8	16	32	63	125	250	500
<b>B</b>	4	1.0	1.0	1.0	1.0	1.3	1.3	1.3	1.3	1.3
	8	1.3	1.3	1.3	1.3	1.5	1.5	1.5	1.5	1.5
	16	1.5	1.5	1.5	1.5	1.8	1.8	1.8	1.8	1.8
	24	1.8	1.8	1.8	1.8	2.2	2.2	2.2	2.2	2.2
APPLICAZIONI / APPLICATIONS / ANWENDUNGEN										
Agitatori per liquidi e solidi Alimentatori a nastro Argani con medio servizio Filtri con pietre e ghiaia Viti per espulsione acqua Flocculatori Filtri a vuoto Elevatori a tazze Gru			<i>Liquid and solid agitators</i> <i>Belt conveyors</i> <i>Medium service winches</i> <i>Stone and gravel filters</i> <i>Dewatering screws</i> <i>Flocculator</i> <i>Vacuum filters</i> <i>Bucket elevators</i> <i>Cranes</i>			Rührwerke für Flüssigkeiten und Feststoffe Bandförderer Mittlere Winden Filter mit Steinen/Kies Abwasserschnecken Flockvorrichtungen Vakuumfilter Becherwerke Kräne				

Classe di carico <i>Load class</i> Lastklasse	h/gg <i>h/d</i> St./Tag	N. AVVIAMENTI/ORA / N. START-UP/HOUR / ANZAHL DER STARTVORGÄNGE PRO STUNDE								
		2	4	8	16	32	63	125	250	500
<b>C</b>	4	1.3	1.3	1.3	1.3	1.5	1.5	1.5	1.5	1.5
	8	1.5	1.5	1.5	1.5	1.8	1.8	1.8	1.8	1.8
	16	1.8	1.8	1.8	1.8	2.2	2.2	2.2	2.2	2.2
	24	2.2	2.2	2.2	2.2	2.5	2.5	2.5	2.5	2.5
APPLICAZIONI / APPLICATIONS / ANWENDUNGEN										
Argani per servizio pesante Estrusori Calandre per gomma Presse per mattoni Piallatrici Mulini a sfera			<i>Heavy duty hoists</i> <i>Extruders</i> <i>Crusher rubber calenders</i> <i>Brick presses</i> <i>Planing machine</i> <i>Ball mills</i>			Winden für schwere Lasten Extruder Gummikalander Ziegelpressen Hobelmaschinen Kugelmühle				

### 1.3 Selezione

Determinare la potenza in entrata  $P'$  (in base alla coppia  $T_2$  richiesta dall'applicazione) con la seguente formula:

### 1.3 Selection

Calculate input power  $P'$  (on the basis of the torque  $T_2$  required by the application), using the following formula:

$$P' = \frac{T_2' \cdot n_2}{9550 \cdot \eta} \quad [\text{kW}]$$

### 1.3 Wahl

Bestimmen Sie die Antriebsleistung  $P'$  (je nach dem bei der Anwendung erforderlichen Drehmoment  $T_2$ ) mit Hilfe der folgenden Formel:

Calcolare il rapporto di trasmissione con la relazione:

Calculate the transmission ratio with the following equation:

$$i_n = \frac{n_1}{n_2}$$

Berechnen Sie das Untersetzungsverhältnis mit Hilfe der Gleichung:

Scegliere il fattore di servizio FS dell'applicazione nella Tab. 2.

Select the service factor FS of the application in Table 2.

Wählen Sie den Betriebsfaktor FS der Anwendung aus der Tabelle 2 aus.

#### Scelta riduttore

A)  $n_1 = 1400 \text{ min}^{-1}$

Si sceglierà nelle tabelle delle prestazioni dei riduttori un gruppo che in corrispondenza di un rapporto prossimo a quello calcolato ammetta una potenza:

#### Selecting a gearbox

A)  $n_1 = 1400 \text{ min}^{-1}$

Consult the gear unit efficiency table; select a group whose ratio is close to the calculated ratio and which permits power:

#### Wahl des Getriebes

A)  $n_1 = 1400 \text{ min}^{-1}$

Aus der Tabelle der Leistungen der Untersetzungsgetriebe wählt man eine Baugruppe aus, die ein ähnliches Untersetzungsverhältnis zu dem berechneten Wert aufweist und die die folgende Leistung zulässt:

$$P \geq P' \times \text{FS}$$

B)  $n_1 \neq 1400 \text{ min}^{-1}$

Si dovrà effettuare la scelta come nel caso precedente però in base ad una potenza  $P_c$  corretta con i coefficienti riportati nelle tabelle relative ad ogni tipologia di riduttore verificando la relazione:

B)  $n_1 \neq 1400 \text{ min}^{-1}$

Make the selection as described above but on the basis of power  $P_c$  corrected by the coefficients reported in the tables. The following equation should be checked out:

B)  $n_1 \neq 1400 \text{ min}^{-1}$

Die Wahl wird wie im obigen Fall ausgeführt, allerdings auf der Basis einer Leistung  $P_c$ , die mit den Koeffizienten korrigiert wurde. Dabei ist das folgende Verhältnis zu überprüfen:

$$P_c \geq P' \times \text{FS}$$

#### Scelta del motoriduttore

C)  $n_1 = 1400 \text{ min}^{-1}$  e  $\text{FS} = 1$

Si cercherà nelle tabelle della prestazioni dei motoriduttori un gruppo la cui potenza  $P_1$  corrisponda alla  $P'$  calcolata.

D)  $n_1 \neq 1400 \text{ min}^{-1}$  o se il fattore  $\text{FS} \neq 1$

La scelta dovrà essere effettuata come al punto A) verificando che la grandezza del motore da installare sia compatibile con quelle ammesse dal riduttore (IEC); ovviamente la potenza installata dovrà corrispondere al valore  $P'$  richiesto.

#### Selecting a gearmotor

C)  $n_1 = 1400 \text{ min}^{-1}$  and  $\text{FS} = 1$

Consult the gear motor efficiency table and select a group having power  $P_1$  corresponding to calculated  $P'$ .

D)  $n_1 \neq 1400 \text{ min}^{-1}$  or  $\text{FS} \neq 1$

Follow the instructions at point A), checking that the size of the motor to be installed is compatible with the gear unit (IEC); obviously, installed power must correspond to the required  $P'$  value.

#### Wahl des Getriebemotors

C)  $n_1 = 1400 \text{ min}^{-1}$  und  $\text{FS} = 1$

In den Leistungstabellen der Getriebemotoren sucht man eine Baugruppe, deren Leistung  $P_1$  der berechneten Leistung  $P'$  entspricht.

D)  $n_1 \neq 1400 \text{ min}^{-1}$  oder  $\text{FS} \neq 1$

Die Auswahl wird wie unter A) getroffen, wobei zu überprüfen ist, ob die Größe des zu installierenden Motors mit dem Untersetzungsgetriebe kompatibel ist (IEC); selbstverständlich muß die Einbauleistung dem erforderlichen Wert  $P'$  entsprechen.

## Verifiche

Verificare che i carichi radiali agenti sugli alberi rientrino nei valori ammissibili riportati nelle relative tabelle.

Tali valori ( $F_{R2}$ ) si riferiscono a carichi che agiscono a metà sporgenza dell'albero, per cui se il punto di applicazione è diverso, è necessario effettuare il calcolo dei nuovi valori ammissibili alla distanza ( $y$ ) desiderata.

Analogamente a quanto precisato sopra, anche i carichi assiali dovranno essere oggetto di verifica confrontandoli con i valori delle relative tabelle.

### Sovraccarichi

Durante il normale funzionamento del riduttore è ammesso un sovraccarico istantaneo di emergenza pari al 100% della coppia indicata  $T_2$ .

Se si temono sovraccarichi frequenti o superiori è indispensabile prevedere degli opportuni dispositivi per la limitazione della coppia.

### Ingranaggi

Il calcolo a durata ed a fatica degli ingranaggi viene eseguito secondo la norma ISO 6336 e ISO 10300, considerando l'impiego di olio sintetico.

## Check-list

*Check that the radial loads on the shafts fall within to the admissible values reported in the relative tables.*

*Reported values ( $F_{R2}$  refer to loads which affect the shaft at the half-way point of its projection; if the point of application is different, it is necessary to calculate the new admissible values at the desired distance ( $y$ ).*

*In keeping with the above guidelines, axial loads should also be checked against the values reported in the relative tables.*

### Overloads

*An emergency momentary overload up to 100% of  $T_2$  torque is allowed during standard operation of the gearbox.*

*Should frequent or higher overloads be expected, it is necessary to install torque limiting devices.*

### Gears

*Life and fatigue of the gears are calculated in compliance with ISO 6336 and ISO 10300. Calculations refer to utilization of synthetic oil*

## Überprüfungen

Es ist zu ueberpruefen, ob die, dass die auf die Wellen wirkenden Radiallasten unter den in der Tabellen angegebenen zulässigen Werten fallen.

Werte beziehen sich auf Lasten, die in der  $F_{R2}$  Mitte der herausragenden Welle wirken; bei verschiedenem Ansatzpunkt ist es daher erforderlich, die neuen, beim gewünschten Abstand ( $y$ ) zulässigen Werte zu berechnen.

Ähnlich wie oben, müssen auch Axialbelastungen überprüft werden, indem man sie mit den Werten der jeweiligen Tabellen vergleicht.

### Überbelastungen

Eine augenblickliche Notfall-Überbelastung zu 100% des  $T_2$  Drehmoments darf während Getriebestandardbetrieb eintreten.

Falls häufige und höhere Überlastungen erwartet werden, sind die entsprechenden Vorrichtungen zur Begrenzung des Drehmoments anzubringen.

### Räderwerk

Dauer und Belastung werden gemäß ISO 6336 und ISO 10300 berechnet. Dabei wird die Anwendung von synthetischem Oel berücksichtigt

## 1.4 Potenza Termica

Nelle tabelle riportate nelle sezioni relative ad ogni tipologia di riduttore sono indicati i valori della potenza termica nominale  $P_{t0}$  (kW). Tale valore rappresenta la potenza massima applicabile all'entrata del riduttore, in servizio continuo a temperatura ambiente di 30°C, così che la temperatura dell'olio non oltrepassi il valore di 95°C, valore massimo ammesso nel caso di prodotti standard.

**Il valore di  $P_{t0}$  non deve essere preso in considerazione** se il funzionamento è continuo per un massimo di 1.5 ore seguito da pause di durata sufficiente (circa 1 – 2 ore) a ristabilire nel riduttore la temperatura ambiente.

I valori di  $P_{t0}$  devono essere corretti tramite i seguenti coefficienti, così da considerare le reali condizioni di funzionamento, ottenendo i valori di potenza termica corretta  $P_{tc}$ .

## 1.4 Thermal power

*The different sections dedicated to each type of gearbox contain tables reporting the values of rated thermal power  $P_{t0}$  (kW). Reported values correspond to the maximum admissible power at gearbox input, on continuous duty and with ambient temperature of 30°C, so that oil temperature does not exceed 95°C, which is the max. admissible value for standard products.*

**$P_{t0}$  value should not be taken into account in case of continuous duty for max. 1.5 hours followed by pauses which are long enough to bring the gearbox back to ambient temperature (roughly 1 – 2 hours).**

*In order to comply with the actual operating conditions,  $P_{t0}$  values should be corrected with the following coefficients, thus obtaining the values of corrected thermal power  $P_{tc}$ .*

## 1.4 Thermische Leistung

Für jeden Getriebetyp gibt es Tabellen, die die Nennwerte der thermischen Leistung  $P_{t0}$  (kW) angeben. Die angegebenen Werte stellen die max. anwendbare Antriebsleistung der Getriebe im Dauerbetrieb mit einer Umgebungstemperatur von max. 30°C dar, sodass die Öltemperatur unter 95°C bleibt (max. Wert für Standardprodukte).

**$P_{t0}$  Wert darf nicht betrachtet werden**, falls Dauerbetrieb max. 1.5 Stunden dauert und von Stillstand gefolgt wird, der lang genug ist, damit das Getriebe zur Umgebungstemperatur zurück kommt. (ungefähr 1 – 2 Stunden).

$P_{t0}$  Werte sollen durch die folgenden Koeffizienten verbessert werden, Damit die reellen Betriebsbedingungen wirklich in Betracht gezogen werden. Mit der folgenden Formel erhält man die Werte der korrekten thermischen Leistung  $P_{tc}$ .

$$P_{tc} = P_{t0} \cdot ft \cdot fv \cdot fu \text{ (kW)}$$



Dove:  
ft = coefficiente di temperatura (v. tab. 3)

Where:  
ft = temperature coefficient (see table 3)

Dabei ist:  
ft = Temperaturkoeffizient (siehe Tabelle 3)

Tab. 3

Tc (°C)	0	5	10	15	20	25	30	35	40	45	50
ft	1.46	1.38	1.31	1.23	1.15	1.1	1	0.92	0.85	0.77	0.69

(Dove Tc (°C) è la temperatura ambiente)

(Tc (°C) is the ambient temperature)

(Tc (°C) ist die Umgebungstemperatur)

fv = coefficiente di ventilazione  
fv= 1.45 con ventilazione forzata efficace con ventola dedicata  
fv= 1.25 con ventilazione forzata secondaria ad altri dispositivi (pulegge, ventole motore, ecc.)  
fv= 1 refrigerazione naturale (situazione standard)  
fv= 0.5 in ambiente chiuso e ristretto (carter)

fv = cooling coefficient  
fv= 1.45 forced cooling with specific fan  
fv= 1.25 forced cooling secondary to other devices (pulleys, motor fans, etc)  
fv= 1 natural cooling (standard)  
fv= 0.5 in a closed and narrow environment

fv = Luftkühlungskoeffizient  
fv= 1.45 Drucklüftung mit Sonderlüfterrad  
fv= 1.25 Drucklüftung nebensächlich zu anderen Vorrichtungen (Scheiben, Motorlüfterräder, usw.)  
fv= 1 natürliche Lüftung (Standard)  
fv= 0.5 in engem und geschlossenem Raum

fu = coefficiente di utilizzo (v. tab. 4)

fu = utilization coefficient (see table 4)

fu = Verwendungskoeffizient (siehe Tabelle 4)

Tab. 4

Dt (min)	10	20	30	40	50	60
fu	1.6	1.35	1.2	1.1	1.05	1

Dove Dt sono i minuti di funzionamento in un'ora

Dt is minutes of operation per hour

Dt steht für Betriebsminuten pro Stunde

### 1.5 Verifica del dispositivo antiritorno

Dopo aver correttamente selezionato il riduttore, occorre verificare se il valore del momento torcente  $T_{2M}$  max garantito all'asse uscita del riduttore dal dispositivo antiritorno, considerate le reali condizioni di esercizio, è sufficiente a garantire il buon funzionamento dell'applicazione. Deve pertanto essere verificata la seguente relazione:

### 1.5 Check of back stop device

After having selected the gearbox it is necessary to check whether the max. output torque  $T_{2M}$  max guaranteed by the backstop device, in view of the actual operating conditions, is sufficient to ensure the good functioning of the application. The following equation has to be checked out:

### 1.5 Prüfung der Rücklaufsperr

Nach der Wahl des Getriebes muss sichergestellt werden, dass das von der Rücklaufsperr garantierte Abtriebsdrehmoment  $T_{2M}$  max hoch genug ist, damit der korrekte Ablauf der Applikation unter Berücksichtigung der wirklichen Betriebsbedingungen gewährleistet wird. Die folgende Relation ist festzustellen:

$$T_{2M} \max = T_{2NOM} \cdot fc \cdot fa \cdot ft \quad (1)$$

Dove:  
 $T_{2NOM}$  [Nm]: è il momento torcente che deve essere garantito all'asse uscita del riduttore, nell'istante in cui viene interrotta la trasmissione del moto, affinché sia soddisfatta la condizione di irreversibilità del moto.  $T_{2NOM}$  dipende dalle specifiche dell'applicazione e deve essere valutato volta per volta.

fc: fattore di carico  
fc=1 in caso di funzionamento regolare  
fc=1.3 in caso di funzionamento con urti moderati  
fc=1.8 in caso di funzionamento con forti urti

Where:  
 $T_{2NOM}$  [Nm]: is the torque that must be guaranteed at gearbox output when motion transmission is stopped, in order that motion irreversibility is ensured.  $T_{2NOM}$  depends on application features and should be assessed each time.

fc: load factor  
fc=1 in case of standard operation  
fc=1.3 in case of operation with moderate shocks  
fc=1.8 in case of operation with heavy shocks

Dabei ist:  
 $T_{2NOM}$  [Nm]: Drehmoment, das am Getriebebetrieb garantiert werden muss, wenn die Übertragung der Bewegung stoppt, damit Irreversibilität gewährleistet wird.  $T_{2NOM}$  hängt ab von den Merkmalen der Applikation, d. h.  $T_{2NOM}$  muss jeweils bewertet werden.

fc: Last-Faktor  
fc=1 bei Standardbetrieb  
fc=1.3 bei Betrieb mit mäßigen Stößen  
fc=1.8 bei Betrieb mit starken Stößen

#### NOTA:

Per funzionamento regolare si intende il caso in cui il dispositivo antiritorno, in attesa della ripresa della normale attività del riduttore, mantiene la macchina ferma. Se invece, nel momento in cui il dispositivo antiritorno è azionato (quindi il riduttore è fermo), il carico in uscita aumenta di intensità si possono avere degli urti (moderati o forti).

#### NOTE:

By standard running we mean that the back stop device keeps the machine stationary, whilst awaiting the restart of the gearbox operation. On the contrary in case the back stop device is enabled (motionless gearbox) and the output load gets heavier, moderate or heavy shocks might occur.

#### ANMERKUNG:

Im Standardbetrieb wird der Abtrieb bei einem Maschinenstopp durch die Rücklaufsperr blockiert. Ein erneuter Start löst die Rücklaufsperr wieder. Treten im Stillstand mässige oder starke Laststösse auf, müssen diese bei der Getriebeauslegung berücksichtigt werden.

**fa:** fattore di applicazione, ricavabile dalla seguente tabella (tab. 5) in funzione del numero di inserzioni/ora e dal numero di ore di funzionamento al giorno del riduttore

**fa:** application factor, as shown in the following table (tab. 5), depending on the number of backstop device insertions per hour and the number of gearbox operating hours per day.

**fa:** Anwendungsfaktor, wie es in der folgenden Tabelle (Tab.5) angegeben wird. Der Anwendungsfaktor hängt von der Zahl der Einschaltungen der Rücklaufsperrung pro Stunde und von Betriebsstunden des Getriebes pro Tag ab.

Tab. 5

h/gg - h/d - St./Tag	n° INSERZIONI / h - INSERTIONS / H - NR. EINSCHALTUNGEN / STUNDE					
	2	4	8	16	32	63
8	1	1	1.1	1.2	1.3	1.4
16	1.3	1.3	1.4	1.5	1.6	1.7
24	1.5	1.5	1.6	1.7	1.8	1.9

**ft:** fattore di temperatura ricavabile dalla seguente tabella (tab.6) in funzione della temperatura ambiente di funzionamento.

**ft:** temperature factor, as shown in the following table (tab. 6) depending on ambient temperature during gearbox operation.

**ft:** Temperaturfaktor, wie es in der folgenden Tabelle (Tab.6) angegeben wird. Der Temperaturfaktor hängt von der Umgebungstemperatur während des Getriebebetriebs ab.

Tab. 6

Tamb (°C)	-20°	-10°	0°	10°	20°	30°	40°	50°
ft	1.2	1.15	1.1	1.05	1	1.03	1.05	1.10

**Se la relazione (1) a pag. 6 non risulta essere verificata** si prenda in considerazione la possibilità o di variare il rapporto di riduzione, individuando una alternativa migliore, o di passare alle grandezze di riduttori successive.

**If the result of the calculation does not correspond to the equation (1) at page 6,** either the ratio has to be modified or a bigger size of gearbox has to be selected.

**Falls das Resultat nicht der Relation (1) entspricht (Seite 6),** muss entweder das Untersetzungsverhältnis oder die Größe des Getriebes geändert werden.

Nel caso in cui il riduttore, provvisto di dispositivo antiritorno, si trovi ad operare ad una temperatura ambiente minore di 0°C il riduttore può essere fornito, a seconda del rapporto di riduzione, in esecuzione speciale (con camera stagna) così da migliorare il funzionamento del dispositivo. Per quanto riguarda quest'ultima soluzione si contatti il servizio tecnico Tramec.

*If the ambient temperature is below 0°C, the gearbox with backstop device can be supplied in the special execution (with tight chamber) which improves the functioning of the backstop device. Please contact Tramec Technical Dept. for further information.*

Liegt die Umgebungstemperatur unter 0°C, wird empfohlen, die Sonderausführung des Getriebes (mit Dichtkammer) zu benutzen, damit die Rücklaufsperrung am besten funktioniert. Für weitere Auskünfte darüber soll man sich mit Tramec technischen Büro in Verbindung setzen.

## 1.6 Lubrificazione

I cuscinetti dell'albero veloce vengono sempre lubrificati con grasso a base sintetica; altri cuscinetti vengono lubrificati solo se la posizione di montaggio non ne garantisce la corretta lubrificazione.

Una scelta oculata del tipo di lubrificante, in funzione delle condizioni operative e ambientali, consente ai riduttori di raggiungere le prestazioni ottimali. Le prestazioni dei riduttori indicate nelle tabelle dei dati tecnici sono state calcolate considerando l'impiego di olio sintetico.

### VISCOSITA'

E'uno dei parametri più importanti da considerare nella scelta di un olio ed è influenzabile da diversi parametri quali velocità, temperatura. Riportiamo sinteticamente le valutazioni generali per la scelta della giusta viscosità:

#### Viscosità alta

Usare per basse velocità di rotazione e/o temperature alte. (Una viscosità troppo bassa in queste condizioni operative causa una usura precoce).

#### Viscosità bassa

Usare per alte velocità di rotazione e/o temperature basse. (Una viscosità troppo elevata provoca diminuzione del rendimento e surriscaldamento).

### ADDITIVI

In tutti gli oli minerali sono contenuti degli additivi antiusura, EP (più o meno energici), antiossidanti ed antischiuma. E' opportuno assicurarsi che essi siano blandi e non aggressivi nei confronti delle guarnizioni.

### BASE DELL'OLIO

Può essere minerale o sintetica. L'olio sintetico, compensa il costo più elevato con una serie di vantaggi:

- a) minor coefficiente d'attrito (quindi migliore rendimento)
- b) migliore stabilità nel tempo (possibile lubrificazione a vita)
- c) migliore indice di viscosità (migliore la adattabilità alle varie temperature).

L'olio a base minerale come vantaggi ha il minore costo e un migliore comportamento in rodaggio.

## 1.6 Lubrication

*The bearings mounted on the input shaft are supplied with grease, synthetic base; the other bearings are lubricated only if the mounting position does not assure a correct lubrication.*

*Choose the lubricant according to operating and ambient conditions in order to ensure high gear unit performance. Performance data, as shown in the specifications tables, refer to utilization of synthetic oil.*

### VISCOSITY

*It is the most important parameter to be considered when selecting an oil; it depends on various factors such as speed and temperature. Following are general guidelines for choosing the correct viscosity:*

#### High viscosity

*To be used for low rotation speed and/or high temperatures. (Under these operating conditions a low viscosity causes premature wear).*

#### Low viscosity

*To be used for high rotation speed and/or low temperatures. (High viscosity reduces efficiency and causes overheating).*

### ADDITIVES

*All mineral oils contain additives to protect against wear, EP (more or less strong), anti-oxidizing and anti-frothing. It is advisable to make sure that the action of such additives is bland and not too aggressive on the seals.*

### OIL BASE

*May be mineral or synthetic. Synthetic oil compensates for the higher cost with a series of advantages :*

- a) *lower friction coefficient (consequently improved efficiency)*
- b) *better stability over time (possible life lubrication)*
- c) *better viscosity index (more adaptable to various temperatures).*

*Mineral-base oils offer the advantages of costing less and performing better during the running-in period.*

## 1.6 Ölschmierung

Die Kugellager auf der Eingangswelle werden immer mit synthetischem Fett geliefert. Falls die Montage keine korrekte Schmierung gewährleistet, dann werden die restlichen Lager mit Schmiermittel geliefert. Das Untersetzungsgetriebe wird optimal arbeiten, wenn das richtige Schmiermittel je nach Betriebs- und Umgebungsbedingungen sorgfältig ausgewählt wird. Daten über Getriebeleistung, wie es in den Tabellen der technischen Daten angegeben wird, beziehen sich auf Schmierung mit synthetischem Öl.

### VISKOSITÄT

Die Viskosität ist eines der wichtigsten Merkmale, die bei der Auswahl des richtigen Öls zu beachten sind; sie wird von verschiedenen Parametern wie Geschwindigkeit und Temperatur beeinflusst. Im folgenden fassen wir die wichtigsten allgemeinen Hinweise für die Wahl der richtigen Viskosität zusammen:

#### Hohe Viskosität

Geeignet für niedrige Drehzahlen bzw. hohe Temperaturen. (Eine zu geringe Viskosität verursacht unter diesen Betriebsbedingungen frühen Verschleiß).

#### Geringe Viskosität

Geeignet für hohe Drehzahlen bzw. niedrige Temperaturen. (Eine zu hohe Viskosität führt in diesem Fall zu einer Verringerung des Wirkungsgrades und zur Überhitzung).

### ZUSAETZE















Alle Mineralöle enthalten Antiverschleiß-Zusätze, EP (mehr oder weniger stark), Oxydationsschutzmittel und Mittel gegen Schaumbildung. Es soll sichergestellt werden, daß diese Zusätze schwach sind und die Dichtungen nicht angreifen.

### ÖLGRUNDLAGE

Es kann sich dabei um Mineralöl oder synthetisches Öl handeln. Synthetisches Öl ist kostenintensiver, bietet jedoch viele Vorteile:

- a) geringerer Reibungskoeffizient (besserer Wirkungsgrad)
- b) höhere Stabilität über lange Zeit (lebenslange Schmierung möglich)
- c) besserer Viskositätsindex (passt sich besser an Temperaturschwankungen an).

Die Vorteile von Mineralöl sind die niedrigeren Kosten und das bessere Einfahrverhalten.

ISO VG		OLIO MINERALE / MINERAL OIL / MINERALÖL			OLIO SINTETICO / SYNTHETIC OIL / SYNTETISCHES ÖL				
		460	320	220	460	320	220	150	
Temperatura ambiente Amb. Temp. Tc (°C) Umgebungstemperatur		5° ÷ 45°	0° ÷ 40°	-5° ÷ 35°	-15° ÷ 100°	-20° ÷ 90°	-25° ÷ 80°	-30° ÷ 70°	
<b>MINERALE / MINERAL / MINERAL</b>									
FORNITORE / MANUFACTURER / HERSTELLER	MINERALE / MINER. / MINER.	SHELL		Omala OIL 460	Omala OIL 320	Omala OIL 220			
	BP		Energol GRXP 460	Energol GRXP 320	Energol GRXP 220				
	TEXACO		Meropa 460	Meropa 320	Meropa 220				
	CASTROL		Alpha SP 460	Alpha SP 320	Alpha SP 220				
	KLUBER		Lamora 460	Lamora 320	Lamora 220				
	MOBIL		Mobilgear 634	Mobilgear 632	Mobilgear 630				
<b>Tecnologia PAG (polialcoliglicoli) / PAG Technology (polyalkyleneglycol) / PAG (Polyalkylglikole)</b>									
PAG	SHELL					Omala S4 WE 460	Omala S4 WE 320	Omala S4 WE 220	Omala S4 WE 150
	BP					Energol SGXP460	Energol SGXP320	Energol SGXP220	Energol SG 150
	TEXACO					Synlube CLP 460	Synlube CLP 320	Synlube CLP 220	
	AGIP						Agip Blasias S 320	Agip Blasias S 220	Agip Blasias S 150
<b>Tecnologia PAO (polialcoliolefini) / PAO Technology (polyalphaolefin) / PAO (Polyalphaolefine)</b>									
PAO	SHELL					Omala OIL RL/HD 460	Omala OIL RL/HD 320	Omala OIL RL/HD 220	Omala OIL RL/HD 150
	CASTROL					Alpha Synt 460	Alpha Synt 320	Alpha Synt 220	Alpha Synt 150
	KLUBER					Synteso D460 EP	Synteso D320 EP	Synteso D220 EP	Synteso D150 EP
	MOBIL					SHC 634	SHC 632	SHC 630	SHC 629

### 1.7 Installazione

Montare il riduttore in modo tale da eliminare qualsiasi vibrazione.

Curare particolarmente l'allineamento del riduttore con il motore e la macchina da comandare interponendo dove è possibile giunti elastici od autoallineanti.

Quando il riduttore è sottoposto a sovraccarichi prolungati, urti o pericoli di bloccaggio, installare salvamotori, limitatori di coppia, giunti idraulici od altri dispositivi similari.

Fare attenzione a non superare i valori consentiti di carico radiale ed assiale che agiscono sugli alberi veloce e lento.

Assicurarsi che gli organi da montare sui riduttori siano lavorati con tolleranza **ALBERO ISO h6 FORO ISO H7.**

### 1.7 Installation

*Install the gearbox so that any vibration is eliminated.*

*Take special care with the alignment between the gear units, the motor and the driven machine, fitting flexible or self adjusting couplings wherever possible.*

*If the gearbox is subject to prolonged overloads, shocks or possible jamming, fit overload cutouts, torque limiters, hydraulic couplings or other similar devices.*

*Do not exceed allowed radial and axial loads on the input and output shafts.*

*Ensure that the components to be fitted on the gear units are machined with tolerance **SHAFT ISO h6 HOLE ISO H7.***

### 1.7 Einbau

Das Getriebe ist so zu montieren, daß Schwingungen ausgeschaltet werden.

Insbesondere ist auf die Fluchtung des Getriebes zum Motor und zur Maschine zu achten, wo möglich sind elastische oder selbstfluchtende Kupplungen anzubringen.

Wenn das Getriebe anhaltenden Überlasten, Schlägen oder Blockierungsgefahr ausgesetzt ist, sind Motorschalter, Drehmomentbegrenzer, hydraulische Kupplungen oder ähnliche Vorrichtungen anzubringen. Achten sie darauf, dass die zulässigen Radial- und Axialbelastungen an Antriebs- und Abtriebswelle nicht überschritten werden.

Achten Sie darauf, dass die am Getriebe montierten Elemente mit folgenden Toleranzen bearbeitet sind: **WELLE ISO h6, BOHRUNG ISO H7.**

Prima di effettuare il montaggio pulire e lubrificare le superfici al fine di evitare il pericolo di grippaggio e l'ossidazione da contatto.

*Before assembling, clean and lubricate the surfaces to prevent seizure and contact oxidation.*

Vor der Montage sind die Flächen zu reinigen und zu schmieren, um Festfressen bzw. Kontaktoxidation zu vermeiden.

Il montaggio va effettuato con l'ausilio di tiranti ed estrattori utilizzando il foro filettato posto in testa alle estremità degli alberi.

*Assembly is to be carried out with the aid of tie-rods and extractors, using the threaded hole at the shaft ends.*

Die Montage erfolgt mit Hilfe von Zugstangen und Ausziehvorrichtungen unter Verwendung der Gewindebohrung vorn an den Wellenenden.

Durante la verniciatura si consiglia di proteggere il bordo esterno degli anelli di tenuta per evitare che la vernice ne essichi la gomma pregiudicando la tenuta del paraolio stesso.

*When painting, protect the outside edge of the oil seals to prevent the paint from drying the rubber and impairing sealing properties.*

Während des Lackierens sollte der Außenrand der Dichtungsringe geschützt werden, um zu vermeiden, daß der Lack den Gummi austrocknet, was die Dichtungen beeinträchtigen könnte.

Prima della messa in funzione della macchina accertarsi che la quantità di lubrificante e la posizione dei tappi di livello e sfiato siano conformi alla posizione di montaggio del riduttore e che la viscosità del lubrificante sia adeguata al tipo di carico.

*Before starting up the machine, check that the amount of lubricant and the position of filler and breather plugs are correct for the gear unit mounting position and that the lubricant viscosity is appropriate for the type of load.*

Bevor die Maschine in Betrieb genommen wird, ist sicherzustellen, daß sowohl die Schmiermittelmenge als auch die Position der Ölstand- und der Entlüftungsschraube der Montageposition des Getriebes entsprechen und daß die Schmiermittelviskosität der Belastungsart entspricht.

Se il riduttore viene installato all'aperto si consiglia l'utilizzo del tappo di sfiato con valvola.

*If the gearbox is installed outdoors, we recommend the use of the breather plug with valve.*

Die Anwendung einer Entlüftungsschraube mit Ventil wird empfohlen, wenn das Getriebe im Freien eingebaut wird.

Tutti i riduttori e motoriduttori citati nel presente manuale sono destinati ad un impiego industriale con temperatura ambiente da -20°C a +40°C ad una altitudine max di 1000 m slm.

*All reducers and gear motors mentioned in this catalog are intended for industrial use and operation at a ambient temperature between -20°C and +40°C, at an altitude of max. 1000 m above sea level.*

Alle im vorliegenden Katalog angegebenen Getriebe und Getriebemotoren sind für industriellen Einsatz in einer Umgebungstemperatur von -20°C bis +40°C und in einer max. Höhe von 1000 m über dem Meeresspiegel vorgesehen.

Per tutte le altre avvertenze consultare il manuale di "uso e manutenzione" scaricabile dal sito [www.tramec.it](http://www.tramec.it)

*For all other instructions check the "Use and Maintenance Manual" which can be downloaded from our web site [www.tramec.it](http://www.tramec.it)*

Für weitere Anweisungen laden Sie die "Betriebs- und Instandhaltungsanweisung" aus unsere Webseite [www.tramec.it](http://www.tramec.it) herunter.

## 1.8 Rodaggio

## 1.8 Running-in

## 1.8 Einfahren

Si consiglia di incrementare gradualmente nel tempo la potenza trasmessa oppure limitare il momento torcente resistente della macchina da comandare per le prime ore di funzionamento.

*Increase the transmitted power gradually or limit the resistant torque of the driven machine for the first few operating hours.*

Es ist ratsam, die Leistung nur allmählich zu steigern oder das Widerstandsdrehmoment der Maschine in den ersten Betriebsstunden zu begrenzen.

## 1.9 Manutenzione

## 1.9 Maintenance

## 1.9 Wartung

Per i riduttori lubrificati con olio minerale dopo le prime 500 - 1000 ore di funzionamento sostituire l'olio effettuando, se possibile, un accurato lavaggio interno del riduttore.

*Gear units lubricated with mineral oil, change the oil after the first 500 - 1000 operating hours and if possible thoroughly flush the inside of the gearbox.*

Bei mit Mineralöl geschmierten Getrieben ist nach den ersten 500 bis 1000 Betriebsstunden ein Ölwechsel durchzuführen, dabei sollte das Getriebeinnere möglichst ausgespült werden.

Controllare periodicamente il livello del lubrificante ed effettuare il cambio dopo 4000 ore di funzionamento.

*Check the lubricant level regularly and change after 4000 operating hours. If synthetic oil is used the oil change may take place after 12500 running hours.*

Von Zeit zu Zeit ist der Ölstand zu prüfen, alle 4000 Betriebsstunden sollte ein Ölwechsel stattfinden.

Se è utilizzato olio sintetico il cambio può essere effettuato dopo 12500 ore di funzionamento.

*When the gearbox is left unused in a highly humid environment fill it completely with oil.*

Bei Verwendung von Synthetiköl kann der Ölwechsel alle 12500 Betriebsstunden erfolgen.

Quando il riduttore resta per lungo tempo inattivo in un ambiente con una elevata percentuale di umidità si consiglia di riempirlo completamente di olio.

*Importantly the oil must be returned to the operating level before the unit is used again.*

Wenn das Getriebe lange Zeit in einem Raum mit hoher Luftfeuchtigkeit stillliegt, ist es ratsam, es ganz mit Öl zu füllen.

Naturalmente al momento della successiva messa in funzione sarà necessario ripristinare il livello del lubrificante.

Wird es danach wieder in Betrieb genommen, so ist natürlich vorher der richtige Ölstand wiederherzustellen.

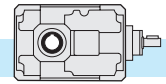

## 2.0

### RIDUTTORE AD ASSI ORTOGONALI

### BEVEL HELICAL GEARBOX

### KEGELSTIRNRADGETRIEBE

2.1	Caratteristiche	<i>Characteristics</i>	Merkmale	12
2.2	Designazione	<i>Designation</i>	Bezeichnung	13
2.3	Sensi di rotazione alberi	<i>Direction of shaft rotation</i>	Drehrichtungen der Wellen	14
2.4	Entrata supplementare	<i>Additional input</i>	Zusatzantrieb	14
2.5	Rendimento	<i>Efficiency</i>	Wirkungsgrad	14
2.6	Velocità in entrata	<i>Input speed</i>	Antriebsdrehzahl	15
2.7	Potenza termica	<i>Thermal power</i>	Thermische Leistung	15
2.8	Dati tecnici	<i>Technical data</i>	Technische Daten	16
2.9	Momenti d'inerzia	<i>Moments of inertia</i>	Trägheitsmoment	18
2.10	Dimensioni	<i>Dimensions</i>	Abmessungen	25
2.11	Accessori	<i>Accessories</i>	Zubehör	32
2.12	Giochi angolari	<i>Angular backlash</i>	Winkelspiel	36
2.13	Lubrificazione	<i>Lubrication</i>	Schmierung	36
2.14	Carichi radiali e assiali	<i>Radial and axial loads</i>	Radial- und Axialbelastungen	38
2.15	Lista parti di ricambio	<i>Spare parts list</i>	Ersatzteilliste	40

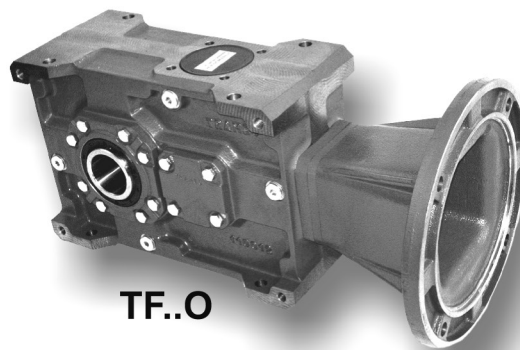

**TF..O**

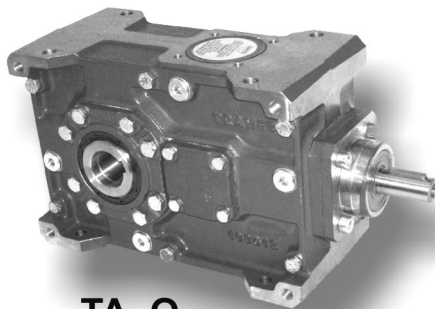

**TA..O**

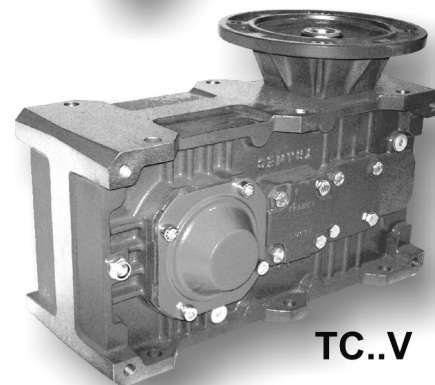

**TC..V**

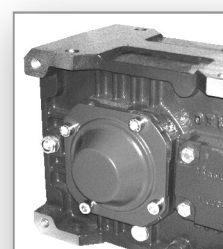
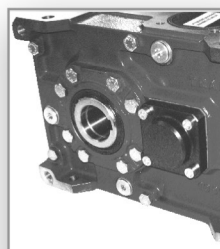
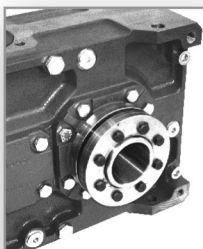

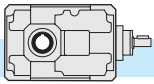

## 2.1 Caratteristiche

- Costruiti in 10 grandezze a 2 riduzioni e in 9 grandezze a 3 riduzioni.
- Sono previsti tre tipi di entrata: con albero entrata sporgente, con predisposizione attacco motore (campana e giunto) e predisposizione attacco motore COMPATTA, escluse grandezze 56, 63 e 75. I tre tipi di entrata possono essere montati indifferentemente nelle esecuzioni verticale e/o orizzontale.
- Il corpo riduttore in lega di alluminio, EN AL - AlSi9Cu - AL - AlSi7 UNI EN 1706 (56-63-75), in ghisa meccanica EN GJL 200 UNI EN 1561, abbondantemente nervato all'interno e all'esterno per garantire la rigidità, è lavorato su tutti i piani per consentire un facile posizionamento; inoltre un'unica camera di lubrificazione garantisce una maggiore dissipazione termica e una migliore lubrificazione di tutti gli organi interni.
- Gli ingranaggi sono costruiti in acciaio legato da cementazione e sottoposti a trattamento di cementazione e tempra. In particolare, la prima riduzione è costituita da due ingranaggi conici a dentatura spirooidale GLEASON con profilo accuratamente rodato, in acciaio 16NiCr4 o 18NiCrMo5 cementati e temprati. Gli ingranaggi cilindrici, a dentatura elicoidale, sono costruiti in acciaio 16NiCr4, 18NiCrMo5 o 20MnCr5 UNI EN 10084 cementati e temprati, rettificati entro la classe di qualità 6 della DIN 3962.
- L'utilizzo dei cuscinetti a rulli conici di qualità su tutti gli assi (ad eccezione del manicotto in entrata nella predisposizione attacco motore compatta, il quale è sostenuto da cuscinetti obliqui a sfere) consente al riduttore di ottenere delle durate molto elevate e di sopportare dei carichi radiali e assiali esterni molto elevati.
- L'albero lento cavo di serie in acciaio (disponibile a richiesta con calettatore), la possibilità di montare una flangia uscita su uno o entrambi i fianchi laterali e la predisposizione per il montaggio del dispositivo antiritorno esaltano la versatilità di questi riduttori facilitandone l'installazione.
- Il corpo riduttore, le flange, le campane ed i coperchi vengono verniciati esternamente di colore BLU RAL 5010, ad eccezione dei riduttori ortogonali delle grandezze 56, 63 e 75 realizzati in alluminio.

## 2.1 Characteristics

- *Built in 10 sizes with 2 reduction stages and in 9 sizes with 3 reduction stages.*
- *Three input types are available : projecting input shaft, pre-engineered motor coupling (bell and joint) and pre-engineered COMPACT motor coupling. (Size 56, 63 and 75 excluded). The 3 input types can be mounted either vertically and/or horizontally.*
- *Gear unit casing in aluminium alloy EN AL - AlSi9Cu - AL - AlSi7 UNI EN 1706 (56-63-75), in engineering cast iron, EN GJL 200 UNI EN 1561, is ribbed internally and externally to guarantee rigidity. It is machined on all surfaces for easy positioning. The single lubrication chamber guarantees improved heat dissipation and improved lubrication of all the internal components.*
- *The gears are built in casehardened compound steel and have undergone case-hardening and quench-hardening treatments. In particular, the first reduction stage consists of two GLEASON spiral bevel gears with precision ground profile, in 16CrNi4 or 18NiCrMo5 case-hardened and quench-hardened steel. The helical spur gears are built in 16NiCr4, 18NiCrMo5 or 20MnCr5 UNI EN 10084 quench-hardened and case-hardened steel, grinded in quality 6 DIN 3962.*
- *The use of high-quality tapered roller bearings on all shafts (except for the input sleeve on the pre-engineered compact motor coupling, which is supported by angular ball bearings) ensures long life and enables very high external radial and axial loads.*
- *The standard hollow output shaft made of steel (shrink disc available on request), the option of mounting an output flange on one or both sides and the possibility of mounting a backstop device make these gear units extremely versatile and easy to install.*
- *Gearbox housing, flanges, bells and covers are externally painted with BLUE RAL 5010, except for bevel helical gearboxes size 56, 63 and size 75 which are made in aluminium.*

## 2.1 Merkmale

- Erhältlich in 10 Größen zu je 2 Untersetzungsstufen und in 9 Größen zu je 3 Untersetzungsstufen.
- Vorgesehen sind drei Antriebsarten: mit vorstehender Antriebswelle, mit Auslegung für Motoranschluß (Glocke und Kupplung), mit Kompaktauslegung für Motoranschluß (Baugröße 56, 63 und 75 ausgenommen). Die drei Antriebstypen können alle sowohl in der vertikalen als auch in der horizontalen Ausführung verwendet werden.
- Die Getriebegehäuse ist aus Aluminiumlegierung EN AL - AlSi9Cu - AL - AlSi7 UNI EN 1706 (56-63-75), Maschienguß EN GJL 200 UNI EN 1561 und mit Rippen versehen, die die Steifheit gewährleisten; die Bearbeitung aller Flächen ermöglicht eine leichte Positionierung; eine einzige Schmierkammer gewährleistet eine höhere Wärmedissipation und eine bessere Schmierung aller inneren Elemente.
- Die Zahnräder bestehen aus legiertem Einsatzstahl, sie wurden einsatz- und abschreckgehärtet. Insbesondere, die erste Untersetzungsstufe besteht aus zwei spiralverzahnten GLEASON – Kegelrädern mit sorgfältig eingelaufenem Profil aus einsatz- und abschreckgehärtetem 16CrNi4- oder 18NiCrMo5. Die Schrägstirnräder bestehen aus einsatz- und abschreckgehärtetem 16NiCr4, 18NiCrMo5- oder 20MnCr5-Stahl UNI EN 10084, geschliffen innerhalb Qualitätsklasse 6 der Spez. DIN 3962.
- An allen Achsen werden Qualitäts-Kegelrollenlager eingebaut. Diese gewährleisten eine hohe Lebensdauer und das Aushalten von sehr hohen Radial- und Axialbelastungen. (Ausnahme: Muffe am Antrieb bei Kompaktauslegung die von Schrägkugellagern gehalten wird)
- Die serienmäßige Abtriebshohlwelle aus Stahl (auf Wunsch mit Schrumpfscheibe erhältlich), die Möglichkeit der Montage eines Abtriebsflansches an einer oder an beiden Seiten und die Auslegung für die Montage der Rücklaufsperrung heben die Vielseitigkeit dieser Untersetzungsgetriebe hervor und erleichtern ihren Einbau.
- Getriebegehäuse, Flansche, Glocken und Deckel werden in BLAU RAL 5010 lackiert (mit Ausnahme von Kegelstirnradgetriebe Größe 56, 63 und 75 die aus Aluminium bestehen).

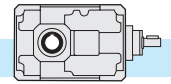

2.2 Designazione

2.2 Designation

2.2 Bezeichnung

Riduttore Gearbox Getriebe	Tipo entrata Input type Antriebsart	Grandezza Size Größe	Rotismo Gearing Räderwerk	Rapporto rid. Ratio Untersetzungsverhältnis	Predisposiz. Motor coupling Motoranschluss	Albero uscita cavo Hollow output shaft Abtriebshohlwelle	Entrata supplementare Additional input Zusatzantrieb	Esecuzione Execution Ausführung	Posizione di montaggio Mounting position Baulage	Flangia uscita Output flange Abtriebsflansch	Antiritorno Back-stop device Rücklaufsperre	Calettatore Shrink disk Schrumpfscheibe
T	A	112	B	10	P.A.M.	-	S.e.A.	O	B3	FLS	CW	C.S.
Riduttore ad assi ortogonali Bevel/helical gearbox Kegelstirradgetriebe	A	56 63 71 75 90 112 140 180 200 225	B	$i_n =$ 5 ... 630	56 ... 225	(1)	A C F	O V	B3 B6 B7 B8 VA VB	FLS	AW	C.S.
	C	56 63 75 80 100 125 160 180 200	C							FLD	CW	C.D.
F										FL2		

(1) Indicare il diametro dell'albero cavo solo se non è standard.  
Es.: TA 112 B 10 90 O B3 40

(1) Diameter of the hollow output shaft to be specified only if it is not standard.  
Ex.: TA 112 B 10 90 O B3 40

(1) Benennen Sie bitte den Durchmesser der Abtriebshohlwelle, insofern dieser nicht dem Standarddurchmesser entspricht  
Beispiel: TA 112 B 10 90 O B3 40

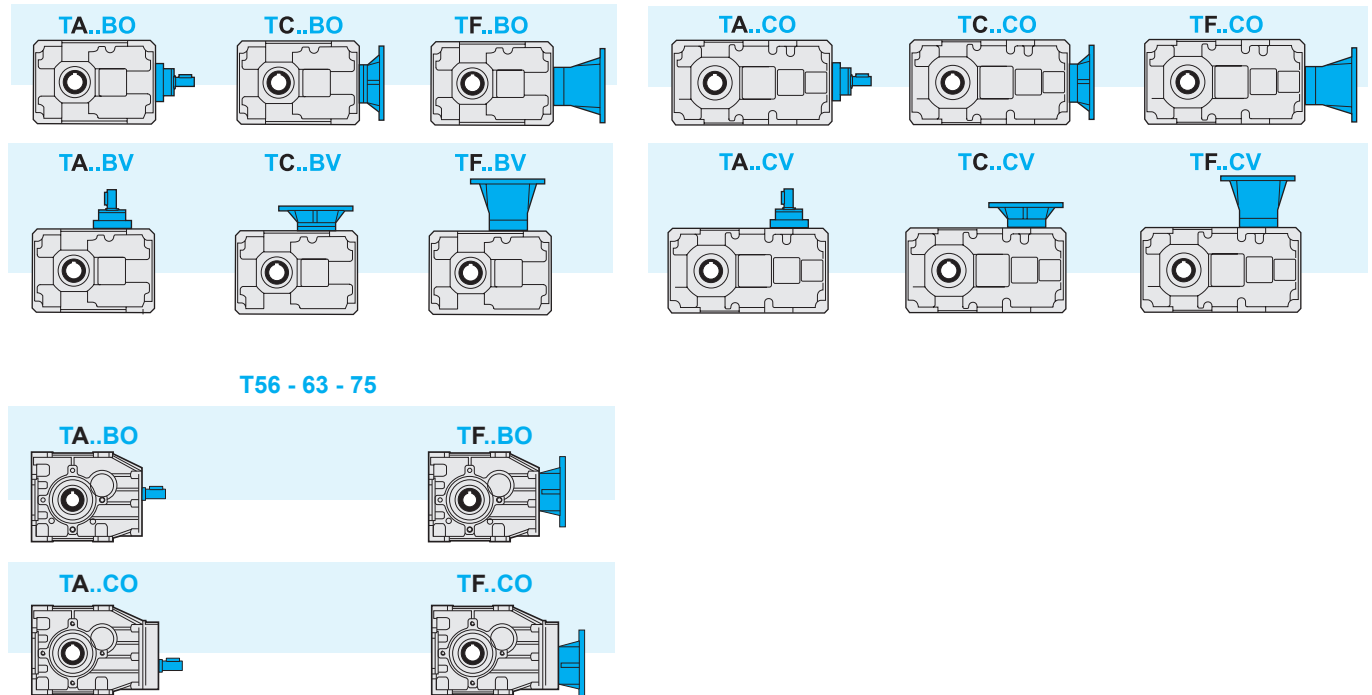

T56 - 63 - 75



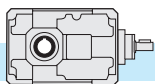

### 2.3 Sensi di rotazione alberi

Nei riduttori esecuzione orizzontale, per ottenere il senso di rotazione contrario al catalogo dell'albero lento mantenendo invariato il senso di rotazione dell'albero veloce, è sufficiente ruotare il riduttore di 180° attorno all'asse dell'albero veloce, utilizzando in pratica il piano di fissaggio opposto.

Nei riduttori esecuzione verticale è possibile fornire il senso di rotazione contrario al catalogo specificandolo al momento dell'ordine.

### 2.3 Direction of shaft rotation

*With regard to horizontal mounted gearboxes, in order to get output rotation in a direction opposite to that given in the catalogue, nevertheless keeping input rotation direction unchanged, simply turn the gearbox 180° around the input shaft; in practice, mount the other way up.*

*Vertical units can be supplied with rotation direction opposite to that given in the catalogue; specify when ordering.*

### 2.3 Drehrichtungen der Wellen

Wenn bei Untersetzungsgetrieben in waagerechter Ausführung für die Abtriebswelle eine andere als die im Katalog angegebene Drehrichtung gewünscht wird und die Antriebswelle ihre Drehrichtung beibehalten soll, so genügt es, das Getriebe um 180° um die Achse der Antriebswelle zu drehen, d.h. die gegenüberliegende Anschlußfläche zu verwenden.

Untersetzungsgetrieben in vertikaler Ausführung sind mit gegensätzlicher Drehrichtung lieferbar, deswegen ist es bei der Bestellung anzugeben, falls die umgekehrte Drehrichtung gewünscht wird.

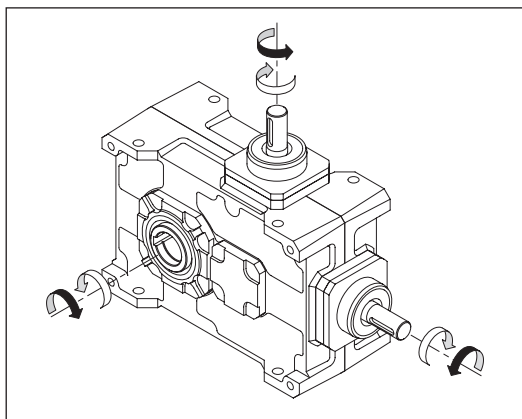

**Sensi di rotazione standard**  
**Standard direction of rotation**  
**Standarddrehrichtungen.**

### 2.4 Entrata supplementare

L'albero entrata può essere montato nella posizione orizzontale (O) o verticale (V), eccetto le grandezze 56,63 e 75. Il cambio di versione può essere facilmente realizzato anche successivamente al primo montaggio.

Eccetto le grandezze 56, 63 e 75, esiste la possibilità di montare una seconda entrata scegliendola, in base alle necessità, tra quelle previste: TA, TC, TF.

In questo caso occorre definire la versione del riduttore con l'entrata principale e specificare quindi la seconda entrata.

### 2.4 Additional input

*The input shaft can be mounted either horizontally (O) or vertically (V) on all sizes except for 56, 63 and 75. The version can be easily changed even after the first assembly.*

*Except for sizes 56, 63 and 75, there is the possibility of mounting a second input; the available options are TA, TC, TF.*

*Both the main input and the additional second input shall be specified when ordering.*

### 2.4 Zusatzantrieb

Die Antriebswelle kann entweder waagrecht (O) oder senkrecht (V) montiert werden ((Baugröße 56, 63 und 75 ausgenommen). Auch nach der ersten Montage kann die Version leicht geändert werden. Mit Ausnahme von den Größen 56,63 und 75 kann ein zweiter Antrieb TA, TC oder TF montiert werden.

Bei der Bestellung sollte sowohl der hauptsächliche Antrieb als auch der zweite Antrieb angegeben werden.

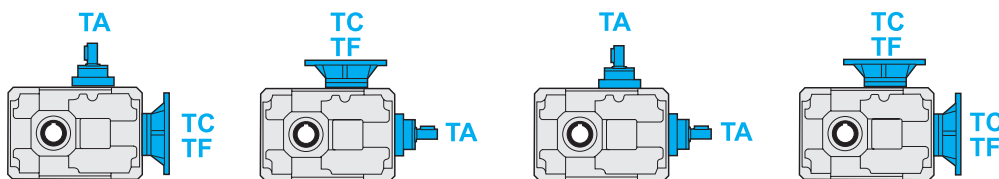

### 2.5 Rendimento

Il valore del rendimento dei riduttori può essere stimato con sufficiente approssimazione in base al numero di riduzioni, trascurando le variazioni non significative attribuibili alle varie grandezze e rapporti.

### 2.5 Efficiency

*The efficiency value of the gear units can be estimated sufficiently well on the basis of the number of reduction stages, ignoring non-significant variations which can be attributed to the various sizes and ratios.*

### 2.5 Wirkungsgrad

Der Wirkungsgrad des Getriebes kann mit ausreichender Annäherung aufgrund der Anzahl der Untersetzungsstufen ermittelt werden. Dabei können die unwesentlichen Veränderungen, die auf die verschiedenen Größen und Untersetzungsverhältnisse zurückzuführen sind, ausser Acht gelassen werden.

$\eta$	T...B	T...C
	0.95	0.93

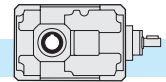

## 2.6 Velocità in entrata

Tutte le prestazioni dei riduttori sono calcolate in base ad una velocità in entrata di 1400 min<sup>-1</sup>.

Tutti i riduttori ammettono velocità fino a 3000 min<sup>-1</sup> anche se è consigliabile, dove l'applicazione lo permette, utilizzare valori inferiori a 1400 min<sup>-1</sup>.

Nella tabella sottostante riportiamo i coefficienti correttivi della potenza in entrata P alle varie velocità riferita ad Fs = 1

Tab. 1

n <sub>1</sub> (rpm)	3000	2800	2200	1800	1400	900	700	500
P <sub>c</sub> (kW)	P x 1.9	P x 1.8	P x 1.48	P x 1.24	P x 1	P x 0.7	P x 0.56	P x 0.42

## 2.7 Potenza termica

I valori delle potenze termiche, P<sub>10</sub> (kW), sono riportati nella tabella seguente, in funzione di grandezza, rapporto e velocità entrata del riduttore.

I valori sono calcolati considerando l'utilizzo di olio sintetico ISO 320.

Vedere paragrafo 1.4 per la scelta dei fattori correttivi.

## 2.6 Input speed

All calculations of gear unit performance are based on an input speed of 1400 min<sup>-1</sup>. All gear units permit speed up to 3000 min<sup>-1</sup>, nevertheless it is advisable to keep below 1400 min<sup>-1</sup>, depending on application.

The table below reports input power P corrective coefficients at the various speeds, with Fs = 1.

## 2.7 Thermal power

The following table shows the values of thermal power P<sub>10</sub> (kW) for each gearbox size on the basis of ratio and input speed.

The values have been calculated considering the utilization of synthetic oil ISO 320.

See chapter 1.4 for the corrective coefficients.

## 2.6 Antriebsdrehzahl

Bei der Berechnung der Getriebeleistungen wurde eine Antriebsdrehzahl von 1400 min<sup>-1</sup> berücksichtigt.

Bei allen Getrieben sind Antriebsdrehzahlen bis 3000 min<sup>-1</sup> möglich; es ist jedoch ratsam, die Drehzahlen unter 1400 min<sup>-1</sup> zu halten, wenn die Anwendung es ermöglicht.

In der folgenden Tabelle finden Sie die Korrekturkoeffizienten für die Antriebsleistung P bei den verschiedenen Drehzahlen, bezogen auf Fs = 1.

## 2.7 Thermische Leistung

Die folgende Tabelle enthält die Werte P<sub>10</sub> der thermischen Leistung (kW) je nach Getriebegröße und abhängig von Untersetzung und von Drehzahlen am Getriebeantrieb. Die angegebenen Werte beziehen sich auf Schmierung mit synthetischen Öl ISO 320.

Im Abschnitt 1.4 finden Sie die Korrekturkoeffizienten.

Potenza Termica / Thermal power / Thermische Leistung																				
P <sub>10</sub> [kW]																				
i <sub>n</sub>	T56B		T63B		T75B		T63B		T90B		T112B		T140B		T180B		T200B		T225B	
	1400	2800	1400	2800	1400	2800	1400	2800	1400	2800	1400	2800	1400	2800	1400	2800	1400	2800	1400	2800
8							-	-	-	-	-	-	-	-	-	48.3	45.4	59	48	
10	4	3.4	5.5	4.7	5.6	4.8	4	6.3	10.8	17	32	43.3	42	55	45.8					
12.5							3.7	5.8	10	15.5	28.7	39	38.5	49	41.5					
16							3.3	5.2	9	14	25.8	33.8	37							
18*	-	-	-	-	-	-	-	-	-	12.9	24.6	-	-							
20							2.8	4.4	7.7	11.8	23.5	30.8	35							
25	4	3.4	5.5	4.7	5.6	4.8	2.7	4.2	7.3	11	21.6	28.6	32.3							
31.5							2.5	3.9	6.8	10.4	20	25.6	27.7							
35*	-	-	-	-	-	-	-	-	-	10	19	-	-							
40	4	3.4	5.5	4.7	5.6	4.8	2.3	3.6	6.3	9.5	18	23.9	25.8							
50			5.5	4.7	5.6	4.8	1.9	3	4.7	7.6	11.3	17.4	-							
63							1.8	2.8	4.4	7.3	10.7	16.6	-							
70*	-	-	-	-	-	-	-	-	-	7	10.3	-	-							
80							1.7	2.6	4.2	6.8	10	-	-							

Potenza Termica / Thermal power / Thermische Leistung																				
P <sub>10</sub> [kW]																				
i <sub>n</sub>	T56C		T63C		T75C		T80C		T100C		T125C		T160C		T180C		T200C			
	1400	2800	1400	2800	1400	2800	1400	2800	1400	2800	1400	2800	1400	2800	1400	2800	1400	2800		
40					-	-	-	-	-	-	-	-	-	-	-	32	34.2			
50							3.6	5.8	9.7	16.8	18.2	21	23.3	30.7	32.6					
63							3.4	5.3	9	15.5	17	19.5	21.6	28.5	30					
80							3.2	5	8.6	14.6	16	18.4	20.4	26.4	27.7					
100	3.3	2.8	4.2	3.6	4.3	3.7	2.9	4.5	7.7	13	14	17	18.4	24.8	27					
125							2.7	4.2	7.3	12.3	13.2	15.6	17	23.3	25.3					
160							2.6	4	7	11.7	12.5	14.7	16	21.8	23.5					
200							2.5	4	6.6	11	12	13.6	14.7	16	17.5					
225*	-	-	-	-	-	-	-	-	-	6	10.2	11	-	-	-	-				
250	3.3	2.8	4.2	3.6	4.3	3.7	2.2	3.3	5.3	9.3	10	12	12.8	15.3	16.7					
315							2	3.2	5.2	9	9.7	11.4	12.3	14.6	15.8					
400							2	3	5	8.6	9.3	10.7	11.5							
450*							-	-	4.9	8.3	9									
500							2	3	4.7	8	8.6									
550*							-	-	4.7	7.9	8.5									
630							2	3	4.6	7.8	8.4									

\* Rapporti speciali / Special ratios / Sonderverhältnisse

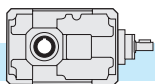

2.8 Dati tecnici

2.8 Technical data

2.8 Technische Daten

T	n <sub>1</sub> = 1400			TC - TF				TA	
	in	ir	n <sub>2</sub> rpm	T <sub>2</sub> Nm	P1 kW	FS'	IEC	T <sub>2M</sub> Nm	P kW
56B	8	8.06	174	94	1.8	1.2	56	110	2.1
	10	10.17	138	120	1.8	1.0	63	120	1.8
	12.5	12.31	114	120	1.5	1.1	(B5)	130	1.6
	16	15.00	93	107	1.1	1.3	71	140	1.4
	20	20.33	69	140	1.1	1.0	80	140	1.1
	25	24.62	57	140	0.9	1.0	90	140	0.90
	31.5	30.00	47	107	0.55	1.3	(B5) (B14)	140	0.70
	40	39.38	36	140	0.55	1.0	TF	140	0.55
	50	48.00	29	115	0.37	1.2	TF	140	0.45
56C	40	40.28	35	140	0.55	1.0	56	140	0.55
	50	50.83	28	119	0.37	1.2	63	140	0.45
	63	61.54	23	140	0.37	1.0	(B5)	140	0.37
	80	75.00	19	119	0.25	1.2	71	145	0.30
	100	101.67	14	145	0.22	1.0	80	145	0.22
	125	123.08	11	141	0.18	1.0	90	145	0.19
	160	150.00	9	124	0.13	1.2	(B5) (B14)	145	0.15
	200	196.92	7	136	0.11	1.1	TF	145	0.12
	250	240.00	6	135	0.09	1.0	TF	135	0.09
63B	8	7.94	176	93	1.8	1.7	56	155	3.0
	10	10.18	138	119	1.8	1.4	63	170	2.6
	12.5	12.50	112	146	1.8	1.3	(B5)	185	2.3
	16	15.88	88	185	1.8	1.0	71	185	1.8
	20	20.36	69	200	1.5	1.0	80	200	1.5
	25	25.00	56	180	1.1	1.1	90	200	1.2
	31.5	31.00	45	181	0.9	1.1	(B5) (B14)	200	1.0
	40	40.00	35	194	0.75	1.0	TF	200	0.80
	50	49.60	28	177	0.55	1.0	TF	200	0.60
63	60.80	23	146	0.37	1.0	TF	170	0.40	
63C	40	39.71	35	194	0.75	1.0	56	200	0.80
	50	50.89	28	178	0.55	1.2	63	210	0.65
	63	62.50	22	210	0.55	1.0	(B5)	210	0.55
	80	79.41	18	186	0.37	1.1	71	210	0.42
	100	101.79	14	161	0.25	1.3	80	210	0.33
	125	125.00	11	198	0.25	1.0	90	210	0.26
	160	155.00	9	210	0.22	1.0	(B5) (B14)	210	0.22
	200	200.00	7	165	0.13	1.3	TF	210	0.17
	250	248.00	6	200	0.13	1.0	TF	200	0.13
315	304.00	5	180	0.09	1.0	TF	180	0.09	
75B	8	7.87	178	204	4.0	1.2	71	245	4.8
	10	9.82	143	254	4.0	1.1	80	279	4.4
	12.5	12.67	110	330	4.0	1.0	90	330	4.0
	16	15.43	91	299	3.0	1.1	100	329	3.3
	20	19.38	72	277	2.2	1.3	112	360	2.9
	25	25.00	56	356	2.2	1.0	(B5) (B14)	356	2.2
	31.5	30.45	46	355	1.8	1.1	TF	391	2.0
	40	40.00	35	285	1.1	1.3	TF	371	1.4
	50	48.73	29	344	1.1	1.1	TF	378	1.2

T	n <sub>1</sub> = 1400			TC - TF				TA	
	in	ir	n <sub>2</sub> rpm	T <sub>2</sub> Nm	P1 kW	FS'	IEC	T <sub>2M</sub> Nm	P kW
75C	50	49.08	29	330	1.1	1.0	63	330	1.1
	63	63.33	22	303	0.75	1.1	(B5)	333	0.8
	80	77.15	18	271	0.55	1.3	71	352	0.70
	100	96.88	14	350	0.55	1.0	80	350	0.55
	125	125.00	11	299	0.37	1.2	90	359	0.44
	160	152.27	9	247	0.25	1.4	(B5) (B14)	346	0.35
	200	200.00	7	317	0.25	1.2	TF	380	0.30
	250	243.64	6	370	0.25	1.0	TF	370	0.25
	71B	10	10.25	137	120	1.8	1.9	63	230
12.5		13.05	107	152	1.8	1.6	71	240	2.8
16		15.63	90	182	1.8	1.4	80	250	2.5
20		19.64	71	229	1.8	1.3	90	290	2.3
25		24.99	56	243	1.5	1.2	(B5)	280	1.7
31.5		29.95	47	213	1.1	1.2	TC-TF	260	1.3
40		38.73	36	226	0.9	1.1	80	240	1.0
50		50.18	28	244	0.75	1.1	(B14)	260	0.80
63		60.13	23	214	0.55	1.2	TC	260	0.70
80	77.76	18	186	0.37	1.3	TC	240	0.50	
90B	5*	4.56	307	118	4	1.8	71	210	7.2
	6.3*	6.26	224	162	4	1.8	80	290	7.2
	10	10.25	137	266	4	1.8	90	480	7.2
	12.5	13.05	107	338	4	1.6	100	530	6.3
	16	15.63	90	405	4	1.4	112	550	5.4
	20	19.64	71	509	4	1.2	(B5)	620	4.9
	25	24.99	56	630	4	1.0	TC-TF	630	4.0
	31.5	29.95	47	560	3	1.0	90*	560	3.0
	40	38.73	36	452	1.8	1.1	(B14)	500	2.0
50	50.18	28	488	1.5	1.1	TC	550	1.7	
63	60.13	23	570	1.5	1.0	TC	570	1.5	
80	77.76	18	454	0.9	1.1	TC	505	1.0	
80C	50	52.18	27	596	1.8	1.1	63	660	2.0
	63	62.53	22	595	1.5	1.1	71	680	1.7
	80	79.58	18	555	1.1	1.3	80	710	1.4
	100	99.97	14	698	1.1	1.1	90	740	1.2
	125	119.78	12	684	0.9	1.1	(B5)	740	1.0
	160	152.45	9	532	0.55	1.3	TC-TF	680	0.70
	200	182.67	8	637	0.55	1.1	80	700	0.60
	250	240.51	6	565	0.37	1.3	(B14)	750	0.49
	315	306.11	5	719	0.37	1.0	TC	740	0.38
400	366.78	4	582	0.25	1.2	TC	700	0.30	
500	474.35	3	660	0.22	1.0	TC	660	0.22	
630	613.46	2	506	0.13	1.2	TC	620	0.16	
112B	5*	4.86	288	290	9.2	1.5	80	430	13.9
	10	10.25	137	611	9.2	1.5	90	920	13.9
	12.5	13.05	107	778	9.2	1.3	100	1000	11.8
	16	15.63	90	932	9.2	1.2	112	1100	10.9
	20	19.64	71	1171	9.2	1.0	132	1190	9.4
	25	24.99	56	1215	7.5	1.1	(B5)	1280	7.9
	31.5	29.95	47	1067	5.5	1.1	TC-TF	1220	6.3
	40	38.73	36	1004	4	1.0	TC-TF	1050	4.2
	50	50.18	28	976	3	1.1	TC-TF	1070	3.3
63	60.13	23	857	2.2	1.3	TC-TF	1140	2.9	
80	77.76	18	907	1.8	1.2	TC-TF	1080	2.1	

- Flange quadrate / Square flanges / Viereckige Flansche
  - \* Rapporti speciali / Special ratios / Sonderverhältnisse
- Verifica termica necessaria / Thermal rating needed / Thermische - Prüfung erforderlich

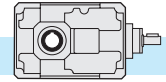

2.8 Dati tecnici

2.8 Technical data

2.8 Technische Daten

T	n <sub>1</sub> = 1400			TC - TF				TA		
	in	ir	n <sub>2</sub> rpm	T <sub>2</sub> Nm	P1 kW	FS'	IEC	T <sub>2M</sub> Nm	P kW	
100C	50	52.18	27	993	3	1.3		1300	3.9	
	63	62.53	22	1190	3	1.1	71	1350	3.4	
	80	79.58	18	1111	2.2	1.3	80	1410	2.8	
	100	99.97	14	1395	2.2	1.1	90	1470	2.3	
	125	119.78	12	1368	1.8	1.1	100	1480	1.9	
	160	152.45	9	1064	1.1	1.3	112	1360	1.4	
	200	182.67	8	1275	1.1	1.1	(B5)	1400	1.2	
	250	240.51	6	1330	0.90	1.1		1500	1.0	
	315	306.11	5	1456	0.75	1.1	90•	1480	0.80	
	400	366.78	4	1280	0.55	1.1	(B14)	1400	0.60	
	500	474.35	3	1113	0.37	1.3	TC	1360	0.50	
630	613.46	2	973	0.25	1.2		1240	0.30		
140B	7*	6.88	203	983	22	1.3		1200	27.9	
	10	10.25	137	1461	22	1.3		1850	27.9	
	12.5	13.05	107	1860	22	1.1		2050	24.3	
	16	15.63	90	1874	18.5	1.2	80	2200	21.7	
	18*	17.43	80	2098	18.5	1.1	90	2300	20.3	
	20	19.64	71	2354	18.5	1.0	100	2400	18.9	
	25	24.99	56	2429	15	1.0	112	2540	15.7	
	31.5	29.95	47	2135	11	1.1	132	2300	11.9	
	35*	33.38	42	1620	7.5	1.4	160	2300	10.6	
	40	38.73	36	1882	7.5	1.2	180	2210	8.8	
	50	50.18	28	1789	5.5	1.2	(B5)	TC-TF	2120	6.5
63	60.13	23	2143	5.5	1.1			2350	6.0	
70*	67.03	21	2376	5.5	1.0			2400	5.5	
80	77.76	18	2016	4	1.1			2250	4.5	
125C	50	52.18	27	2483	7.5	1.1		2650	8.0	
	63	62.53	22	2182	5.5	1.3		2760	7.0	
	80	79.58	18	2777	5.5	1.0		2880	5.7	
	100	99.97	14	2537	4	1.2		3000	4.7	
	125	119.78	12	3000	4	1.0	80	3000	4.0	
	160	152.45	9	2128	2.2	1.3	90	2720	2.8	
	200	182.67	8	2549	2.2	1.1	100	2800	2.4	
	225*	203.63	7	2284	1.8	1.1	112	2580	2.0	
	250	240.51	6	2746	1.8	1.1	132	3050	2.0	
	315	306.11	5	2913	1.5	1.0	(B5)	2960	1.5	
	400	366.78	4	2560	1.1	1.1	TC-TF	2800	1.2	
450*	408.87	3	2350	0.90	1.1		2600	1.0		
500	474.35	3	2640	0.90	1.0		2640	0.90		
550*	528.78	3	2562	0.75	1.1		2800	0.85		
630	613.46	2	2140	0.55	1.2		2550	0.70		
180B	10	10.25	137	1993	30	2.0		3900	58.7	
	12.5	13.05	107	2536	30	1.7		4300	50.9	
	16	15.63	90	3039	30	1.5		4500	44.4	
	18*	17.43	80	3402	30	1.4	100	4800	42.5	
	20	19.64	71	3818	30	1.3	112	5100	40.1	
	25	24.99	56	4859	30	1.1	132	5230	32.3	
	31.5	29.95	47	4269	22	1.1	160	4680	24.1	
	35*	33.38	42	3996	18.5	1.2	180	4650	21.5	
	40	38.73	36	3764	15	1.1	200	4300	17.1	
	50	50.18	28	3577	11	1.2	(B5)	TC-TF	4300	13.2
	63	60.13	23	4286	11	1.1		4780	12.3	
70*	67.03	21	3975	9.2	1.2		4650	10.7		
80	77.76	18	3779	7.5	1.2		4380	8.7		

T	n <sub>1</sub> = 1400			TC - TF				TA		
	in	ir	n <sub>2</sub> rpm	T <sub>2</sub> Nm	P1 kW	FS'	IEC	T <sub>2M</sub> Nm	P kW	
160C	50	52.18	27	4966	15	1.0		5130	15.5	
	63	62.53	22	4363	11	1.2		5350	13.5	
	80	79.58	18	5570	11	1.0		5570	11.0	
	100	99.97	14	5800	9.2	1.0	80	5800	9.2	
	125	119.78	12	5699	7.5	1.0	90	5800	7.6	
	160	152.45	9	5319	5.5	1.0	100	5470	5.7	
	200	182.67	8	4635	4	1.2	112	5560	4.8	
	225*	203.63	7	5149	4	1.1	160	5800	4.5	
	250	240.51	6	5890	4	1.0	180	5890	4.0	
	315	306.11	5	5920	3	1.0	(B5)	5826	3.0	
	400	366.78	4	5119	2.2	1.1	TC-TF	5600	2.4	
450*	408.87	3	5747	2.2	1.0		5700	2.2		
500	474.35	3	5280	1.8	1.0		5280	1.8		
550*	528.78	3	5124	1.5	1.1		5360	1.6		
630	613.46	2	4281	1.1	1.2		4960	1.3		
200B	8	8.14	172	2370	45	2.1		5000	94.8	
	10	10.43	134	3050	45	1.8	112	5500	81.4	
	12.5	12.60	111	3680	45	1.6	132	6000	73.5	
	16	15.63	90	4540	45	1.4	160	6500	64.2	
	20	17.65	79	5170	45	1.3	180	7100	62.1	
	25	24.14	58	7030	45	1.0	200	7150	45.7	
	31.5	29.95	47	7150	37	1.0	(B5)	TC-TF	7250	37.4
	40	33.82	41	6575	30	1.1	225	7300	33.3	
	50	47.93	29	6833	22	1.1	(B5)	7400	23.8	
	63	54.13	26	6489	18.5	1.1	TF	7400	21.1	
	180C	50	53.11	26	6234	18.5	1.1		7240	21.0
63		63.64	22	7280	18.5	1.0	80	7280	18.5	
80		76.85	18	7313	15	1.0	90	7420	15.2	
100		99.97	14	6936	11	1.1	100	7500	11.9	
125		122.88	11	7172	9.2	1.0	112	7500	9.6	
160		147.23	10	7005	7.5	1.1	132	7550	8.1	
200		190.41	7	6644	5.5	1.1	160	7600	6.3	
250		246.73	6	6261	4	1.2	180	7650	4.9	
315		295.63	5	7502	4	1.0	(B5)	TC-TF	7700	4.1
400		382.33	4	7276	3	1.1		7950	3.3	
225B		8	8.44	166	2461	45	3.0		7500	137.1
	10	10.13	138	2955	45	2.8	132	8300	126.4	
	12.5	12.45	112	3630	45	2.5	160	9100	112.8	
	16	15.93	88	4644	45	2.2	180	10000	96.9	
	20	19.13	73	5577	45	1.9	200	10700	86.3	
	25	23.49	60	6850	45	1.6	225	11000	72.3	
	31.5	30.29	46	8832	45	1.3	(B5)	TF	11100	56.6
	40	37.09	38	10800	45	1.0		10800	45.0	
	200C	40	42.62	33	8110	30	1.3		10900	40.3
		50	51.18	27	9740	30	1.1	100	11000	33.9
		63	62.86	22	8772	22	1.3	112	11350	28.5
80		76.97	18	10742	22	1.0	132	11050	22.6	
100		98.04	14	11200	18.5	1.0	160	11200	18.5	
125		120.41	12	11459	15	1.0	180	11500	15.1	
160		147.45	9	10290	11	1.1	200	11200	12.0	
200		196.87	7	11400	9.2	1.0	(B5)	TC-TF	11400	9.2
250		241.79	6	11504	7.5	1.0		11700	7.6	
315		296.07	5	10330	5.5	1.1		11850	6.3	

• Flange quadrate / Square flanges / Viereckige Flansche

\* Rapporti speciali / Special ratios / Sonderverhältnisse

Verifica termica necessaria / Thermal rating needed

Thermische - Prüfung erforderlich

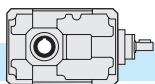

2.9 **Momenti d'inerzia** [Kg·cm<sup>2</sup>]  
(riferiti all'albero veloce in entrata)

2.9 **Moments of inertia** [Kg·cm<sup>2</sup>]  
(referred to input shaft)

2.9 **Trägheitsmoment** [Kg·cm<sup>2</sup>]  
(bez. Antriebswelle)

**TA..B - TC..B - TF..B**

56B	i <sub>n</sub>	TA	TF				
			IEC B5				
			56	63	71	80	90
8	0.25			0.32	0.40	0.60	0.77
10	0.22		0.29	0.29	0.37	0.56	0.74
12.5	0.20		0.27	0.27	0.35	0.54	0.72
16	0.18		0.25	0.26	0.33	0.53	0.71
20	0.08		0.15	0.15	0.22	0.42	0.60
25	0.07		0.14	0.15	0.22	0.42	0.59
31.5	0.07		0.14	0.14	0.21	0.41	0.59
40	0.04		0.11	0.12	0.19	0.39	0.56
50	0.04		0.11	0.11	0.19	0.39	0.56

63B	i <sub>n</sub>	TA	TF				
			IEC B5				
			56	63	71	80	90
8	0.40		0.47	0.47	0.55	0.74	0.92
10	0.34		0.41	0.42	0.49	0.69	0.87
12.5	0.31		0.38	0.38	0.45	0.65	0.83
16	0.16		0.23	0.24	0.31	0.51	0.68
20	0.15		0.22	0.22	0.29	0.49	0.67
25	0.14		0.21	0.21	0.29	0.48	0.66
31.5	0.13		0.20	0.21	0.28	0.48	0.65
40	0.07		0.15	0.15	0.22	0.42	0.60
50	0.07		0.14	0.15	0.22	0.42	0.60
63	0.07		0.14	0.15	0.22	0.42	0.59

75B	i <sub>n</sub>	TA	TF			
			IEC B5			
			71	80	90	100-112
8	1.35		1.70	2.10	2.01	3.05
10	1.21		1.55	1.96	1.87	2.91
12.5	1.05		1.39	1.80	1.71	2.75
16	0.99		1.34	1.74	1.65	2.69
20	0.36		0.71	1.11	1.02	2.06
25	0.32		0.67	1.07	0.98	2.02
31.5	0.30		0.65	1.06	0.97	2.01
40	0.16		0.51	0.92	0.82	1.86
50	0.15		0.50	0.91	0.82	1.86

71B	i <sub>n</sub>	TA	TC				TF			
			IEC B5				IEC B5			
			63	71	80	90	63	71	80	90
10	0.95		1.00	1.14	1.52	1.57	1.20	1.22	1.89	2.96
12.5	0.89		0.94	1.08	1.46	1.51	1.14	1.16	1.83	2.90
16	0.85		0.91	1.05	1.43	1.47	1.11	1.12	1.80	2.87
20	0.38		0.43	0.57	0.94	0.99	0.63	0.65	1.32	2.39
25	0.36		0.41	0.55	0.93	0.98	0.61	0.63	1.31	2.37
31.5	0.35		0.40	0.54	0.92	0.97	0.61	0.62	1.30	2.36
40	0.34		0.39	0.53	0.91	0.96	0.60	0.61	1.29	2.35
50	0.19		0.22	0.36	0.74	0.79	0.44	0.46	1.14	2.20
63	0.19		0.22	0.36	0.74	0.79	0.44	0.46	1.14	2.20
80	0.19		0.22	0.36	0.74	0.79	0.44	0.46	1.13	2.20

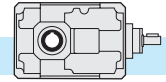







2.9 **Momenti d'inerzia** [Kg·cm<sup>2</sup>]  
(riferiti all'albero veloce in entrata)



2.9 **Moments of inertia** [Kg·cm<sup>2</sup>]  
(referred to input shaft)

2.9 **Trägheitsmoment** [Kg·cm<sup>2</sup>]  
(bez. Antriebswelle)

**TA..B - TC..B - TF..B**

90B	i <sub>n</sub>	TA 	TC 				TF 			
			IEC B5				IEC B5			
			71	80	90	110-112	71	80	90	110-112
5*	4.36	4.77	4.94	5.31	6.15	5.22	5.35	6.53	8.70	
6.3*	3.67	4.07	4.24	4.62	5.46	4.52	4.66	5.84	8.00	
10	2.77	3.18	3.35	3.73	4.57	3.63	3.77	4.94	7.11	
12.5	2.60	3.01	3.18	3.56	4.40	3.46	3.60	4.77	6.94	
16	2.49	2.90	3.07	3.44	4.28	3.35	3.48	4.66	6.82	
20	1.16	1.53	1.70	2.08	2.92	2.02	2.16	3.33	5.50	
25	1.12	1.49	1.66	2.04	2.88	1.98	2.11	3.29	5.45	
31.5	1.09	1.46	1.63	2.00	2.84	1.94	2.08	3.25	5.42	
40	1.06	1.43	1.60	1.98	2.82	1.92	2.05	3.23	5.40	
50	0.65	0.98	1.15	1.53	2.37	1.50	1.64	2.81	4.98	
63	0.64	0.97	1.14	1.52	2.36	1.50	1.63	2.81	4.97	
80	0.63	0.97	1.14	1.51	2.35	1.49	1.62	2.80	4.97	

112B	i <sub>n</sub>	TA 	TC 				TF 			
			IEC B5				IEC B5			
			80	90	110-112	132	80	90	110-112	132
5*	12.20	13.70	13.57	14.53	17.67	14.53	14.46	16.78	30.77	
10	8.51	9.44	9.31	10.26	13.40	10.84	10.77	13.09	27.08	
12.5	7.67	8.60	8.47	9.42	12.56	10.00	9.93	12.25	26.24	
16	7.27	8.20	8.07	9.03	12.16	9.61	9.54	11.85	25.85	
20	3.62	4.46	4.33	5.29	8.43	5.96	5.89	8.20	22.20	
25	3.39	4.23	4.10	5.06	8.20	5.73	5.66	7.97	21.97	
31.5	3.29	4.13	4.00	4.95	8.09	5.62	5.55	7.87	21.86	
40	3.21	4.05	3.92	4.87	8.01	5.55	5.47	7.79	21.79	
50	1.79	2.50	2.37	3.32	6.46	4.13	4.05	6.37	20.37	
63	1.77	2.47	2.35	3.30	6.44	4.10	4.03	6.34	20.34	
80	1.75	2.46	2.33	3.28	6.42	4.08	4.01	6.33	20.32	

140B	i <sub>n</sub>	TA 	TC 						TF 					
			IEC B5						IEC B5					
			80	90	110-112	132	160	180	80	90	110-112	132	160	180
7*	29.65	30.78	30.65	30.79	33.99	38.41	41.43	31.85	34.23	34.40	49.26	51.44	96.71	
10	25.04	26.17	26.04	26.18	29.38	33.80	36.82	27.23	29.62	29.79	44.65	46.83	92.10	
12.5	22.28	23.41	23.28	23.42	26.62	31.05	34.06	24.48	26.86	27.04	41.90	44.08	89.34	
16	21.26	22.39	22.26	22.40	25.60	30.02	33.04	23.46	25.84	26.01	40.87	43.05	88.32	
18*	20.60	21.73	21.60	21.74	24.94	29.36	32.38	22.79	25.18	25.36	40.22	42.40	87.66	
20	9.17	10.13	10.00	10.14	13.34	17.76	20.78	11.37	13.75	13.92	28.78	30.97	76.23	
25	8.42	9.38	9.25	9.39	12.59	17.01	20.03	10.62	13.00	13.17	28.03	30.22	75.48	
31.5	8.14	9.10	8.97	9.11	12.31	16.73	19.75	10.34	12.72	12.90	27.76	29.94	75.20	
35*	7.96	8.92	8.79	8.93	12.13	16.55	19.57	10.16	12.54	12.72	24.58	29.76	75.02	
40	7.92	8.87	8.74	8.88	12.08	16.51	19.52	10.11	12.49	12.67	27.53	29.71	74.98	
50	4.28	4.94	4.81	4.95	8.15	12.57	15.59	6.47	8.85	9.03	23.89	26.07	71.34	
63	4.21	4.87	4.74	4.88	8.08	12.50	15.52	6.40	8.79	8.96	23.82	26.00	71.27	
70*	4.17	4.82	4.69	4.83	8.03	12.45	15.47	6.36	8.74	8.92	23.78	25.96	71.22	
80	4.15	4.81	4.68	4.82	8.02	12.44	15.46	6.35	8.73	8.91	23.77	25.95	71.21	

\* **Rapporti speciali / Special ratios / Sonderverhältnisse**

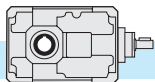







2.9 **Momenti d'inerzia** [Kg·cm<sup>2</sup>]  
(riferiti all'albero veloce in entrata)



2.9 **Moments of inertia** [Kg·cm<sup>2</sup>]  
(referred to input shaft)

2.9 **Trägheitsmoment** [Kg·cm<sup>2</sup>]  
(bez. Antriebswelle)

**TA..B - TC..B - TF..B**

180B	i <sub>n</sub>	TA 	 TC					 TF				
			IEC B5					IEC B5				
			100-112	132	160	180	200	100-112	132	160	180	200
10	78.24	80.83	86.51	85.51	88.42	98.81	97.86	99.23	101.41	150.52	147.05	
12.5	68.84	71.43	77.11	76.11	79.02	89.41	88.46	89.82	92.01	141.12	137.65	
16	66.22	68.81	74.49	73.49	76.40	86.79	85.84	87.20	89.38	138.50	135.03	
18*	64.77	67.36	73.04	72.04	74.95	85.34	84.39	85.75	87.94	137.05	133.58	
20	28.52	31.29	36.97	35.97	38.88	49.27	48.14	49.50	51.68	100.80	97.33	
25	25.96	26.14	31.82	30.82	33.73	44.12	45.58	46.94	49.12	98.24	94.77	
31.5	25.25	28.01	33.69	32.69	35.60	45.99	44.86	46.23	48.41	97.53	94.05	
35*	24.85	27.62	33.3	32.30	35.21	45.60	44.47	45.83	48.01	97.13	93.66	
40	24.43	27.19	32.88	31.88	34.79	45.17	44.04	45.41	47.59	96.71	93.23	
50	11.97	14.25	19.93	18.93	21.84	32.23	31.59	32.95	35.13	84.25	80.78	
63	11.80	14.07	19.75	18.75	21.66	32.05	31.41	32.78	34.96	84.08	80.60	
70*	11.70	13.97	19.66	18.66	21.57	31.95	31.31	32.68	34.86	83.98	80.50	
80	11.59	13.87	19.55	18.55	21.46	31.85	31.21	32.57	34.75	83.87	80.40	

200B	i <sub>n</sub>	TA 	 TC					 TF					
			IEC B5					IEC B5					
			110-112	132	160	180	200	110-112	132	160	180	200	225
8	109.38	110.72	116.40	115.40	118.31	128.70	129.00	130.37	132.55	181.66	178.19	181.78	
10	95.71	97.05	102.73	101.73	104.64	115.03	115.33	116.69	118.87	167.99	164.52	168.11	
12.5	85.34	86.68	92.36	91.36	94.27	104.66	104.96	106.32	108.51	157.62	154.15	157.74	
16	79.58	80.92	86.60	85.60	88.51	98.90	99.20	100.56	102.74	151.86	148.39	151.98	
20	75.15	76.49	82.17	81.17	84.08	94.47	94.77	96.13	98.32	147.43	143.96	147.55	
25	31.37	32.88	38.56	37.56	40.47	50.86	50.98	52.35	54.53	103.65	100.17	103.76	
31.5	29.80	31.31	36.99	35.99	38.90	49.29	49.41	50.78	52.96	102.08	98.60	102.20	
40	28.59	30.11	35.79	34.79	37.70	48.09	48.21	49.57	51.75	100.87	97.40	100.99	
50	20.48	21.49	27.17	26.17	29.08	39.47	40.09	41.46	43.64	92.76	89.28	92.88	
63	20.01	21.02	26.70	25.70	28.61	39.00	39.62	40.99	43.17	92.29	88.81	92.40	

225B	i <sub>n</sub>	TA 	 TF				
			IEC B5				
			132	160	150	200	225
8	265.00	337.3	345.3	343.3	339.8	342.6	
10	249.31	321.6	329.6	327.6	324.1	326.9	
12.5	234.27	306.6	314.5	312.5	309.1	311.9	
16	90.92	163.2	171.2	169.2	165.7	168.5	
20	86.52	158.8	166.8	164.8	161.3	164.1	
25	82.29	154.6	162.6	160.6	157.1	159.9	
31.5	68.32	140.6	148.6	146.6	143.1	145.9	
40	64.25	136.5	144.5	142.5	139.0	141.9	

\* **Rapporti speciali / Special ratios / Sonderverhältnisse**

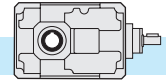





2.9 **Momenti d'inerzia** [Kg·cm<sup>2</sup>]  
(riferiti all'albero veloce in entrata)



2.9 **Moments of inertia** [Kg·cm<sup>2</sup>]  
(referred to input shaft)

2.9 **Trägheitsmoment** [Kg·cm<sup>2</sup>]  
(bez. Antriebswelle)

**TA..C - TC..C - TF..C**

56C	i <sub>n</sub>	TA 	TF 				
			IEC B5				
			56	63	71	80	90
40	0.06	0.136	0.139	0.212	0.410	0.588	
50	0.06	0.134	0.138	0.211	0.409	0.587	
63	0.06	0.134	0.137	0.210	0.408	0.586	
80	0.06	0.133	0.137	0.210	0.408	0.585	
100	0.06	0.129	0.132	0.205	0.403	0.581	
125	0.06	0.129	0.132	0.205	0.403	0.581	
160	0.06	0.128	0.132	0.205	0.403	0.581	
200	0.06	0.127	0.131	0.204	0.402	0.580	
250	0.06	0.127	0.131	0.204	0.402	0.580	

63C	i <sub>n</sub>	TA 	TF 				
			IEC B5				
			56	63	71	80	90
40	0.07	0.142	0.145	0.218	0.416	0.594	
50	0.07	0.139	0.143	0.216	0.414	0.592	
63	0.07	0.138	0.142	0.215	0.413	0.590	
80	0.06	0.132	0.136	0.209	0.407	0.585	
100	0.06	0.132	0.135	0.208	0.406	0.584	
125	0.06	0.131	0.135	0.208	0.406	0.584	
160	0.06	0.131	0.135	0.208	0.406	0.583	
200	0.06	0.129	0.132	0.205	0.403	0.581	
250	0.06	0.129	0.132	0.205	0.403	0.581	
315	0.06	0.129	0.132	0.205	0.403	0.581	

75C	i <sub>n</sub>	TA 	TF 			
			IEC B5			
			63	71	80	90
50	0.104	0.179	0.252	0.450	0.628	
63	0.098	0.173	0.246	0.444	0.622	
80	0.095	0.171	0.244	0.442	0.619	
100	0.070	0.145	0.219	0.417	0.594	
125	0.069	0.144	0.217	0.415	0.593	
160	0.068	0.143	0.216	0.414	0.592	
200	0.062	0.138	0.211	0.409	0.586	
250	0.062	0.137	0.210	0.408	0.586	



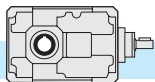







2.9 **Momenti d'inerzia** [Kg·cm<sup>2</sup>]  
(riferiti all'albero veloce in entrata)

2.9 **Moments of inertia** [Kg·cm<sup>2</sup>]  
(referred to input shaft)

2.9 **Trägheitsmoment** [Kg·cm<sup>2</sup>]  
(bez. Antriebswelle)

**TA..C - TC..C - TF..C**

80C	i <sub>n</sub>	TA 	TC 				TF 			
			IEC B5				IEC B5			
			63	71	80	90	63	71	80	90
50	0.90	0.95	1.09	1.47	1.52	1.15	1.17	1.84	2.91	
63	0.86	0.91	1.05	1.43	1.48	1.11	1.13	1.81	2.87	
80	0.86	0.91	1.05	1.43	1.48	1.11	1.13	1.80	2.87	
100	0.36	0.41	0.55	0.93	0.98	0.62	0.63	1.31	2.38	
125	0.35	0.38	0.52	0.90	0.95	0.61	0.62	1.30	2.37	
160	0.35	0.40	0.54	0.92	0.97	0.61	0.62	1.30	2.36	
200	0.35	0.40	0.54	0.92	0.97	0.61	0.62	1.30	2.36	
250	0.19	0.22	0.36	0.74	0.79	0.44	0.46	1.14	2.20	
315	0.19	0.22	0.36	0.74	0.79	0.44	0.46	1.14	2.20	
400	0.19	0.22	0.36	0.74	0.79	0.44	0.46	1.14	2.20	
500	0.19	0.22	0.36	0.74	0.79	0.44	0.46	1.13	2.20	
630	0.19	0.22	0.36	0.74	0.79	0.44	0.46	1.13	2.20	

100C	i <sub>n</sub>	TA 	TC 				TF 			
			IEC B5				IEC B5			
			71	80	90	110-112	71	80	90	110-112
50	2.68	3.08	3.25	3.63	4.47	3.53	3.67	4.84	7.01	
63	2.56	2.96	3.13	3.51	4.35	3.41	3.55	4.72	6.89	
80	2.53	2.94	3.11	3.49	4.33	3.39	3.52	4.70	6.87	
100	1.14	1.51	1.68	2.06	2.89	2.00	2.13	3.31	5.47	
125	1.10	1.47	1.64	2.02	2.86	1.96	2.10	3.27	5.44	
160	1.10	1.47	1.64	2.02	2.86	1.96	2.09	3.27	5.44	
200	1.10	1.47	1.64	2.01	2.85	1.95	2.09	3.26	5.43	
250	0.64	0.98	1.15	1.52	2.36	1.50	1.63	2.81	4.98	
315	0.64	0.97	1.14	1.52	2.36	1.50	1.63	2.81	4.98	
400	0.64	0.97	1.14	1.52	2.36	1.50	1.63	2.81	4.98	
500	0.63	0.97	1.14	1.51	2.35	1.49	1.62	2.80	4.97	
630	0.63	0.97	1.14	1.51	2.35	1.49	1.62	2.80	4.97	

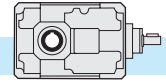







2.9 **Momenti d'inerzia** [Kg·cm<sup>2</sup>]  
(riferiti all'albero veloce in entrata)

2.9 **Moments of inertia** [Kg·cm<sup>2</sup>]  
(referred to input shaft)

2.9 **Trägheitsmoment** [Kg·cm<sup>2</sup>]  
(bez. Antriebswelle)

**TA..C - TC..C - TF..C**

	i <sub>n</sub>	TA 	TC 				TF 			
			IEC B5				IEC B5			
			80	90	110-112	132	80	90	110-112	132
<b>125C</b>	50	7.82	8.75	8.62	9.57	12.71	10.16	10.08	12.40	26.40
	63	7.46	8.39	8.26	9.22	12.36	9.80	9.73	12.04	26.04
	80	7.39	8.32	8.19	9.14	12.28	9.72	9.65	11.97	25.96
	100	3.44	4.28	4.15	5.10	8.24	5.77	5.70	8.02	22.01
	125	3.34	4.18	4.05	5.00	8.14	5.67	5.60	7.92	21.91
	160	3.32	4.16	4.03	4.98	8.12	5.65	5.58	7.90	21.89
	200	3.31	4.15	4.02	4.97	8.11	5.65	5.57	7.89	21.89
	225*	3.31	4.15	4.02	4.97	8.11	4.08	4.01	6.33	20.32
	250	1.78	2.49	2.36	3.31	6.45	4.11	4.04	6.36	20.35
	315	1.77	2.48	2.35	3.31	6.45	4.11	4.04	6.35	20.35
	400	1.77	2.48	2.35	3.30	6.44	4.11	4.03	6.35	20.35
	450*	1.77	2.48	2.35	3.30	6.44	4.10	4.03	6.35	20.35
	500	1.75	2.46	2.33	3.28	6.42	4.08	4.01	6.33	20.32
	550*	1.75	2.46	2.33	3.28	6.42	4.08	4.01	6.33	20.32
630	1.75	2.46	2.33	3.28	6.42	4.08	4.01	6.33	20.32	

	i <sub>n</sub>	TA 	TC 						TF 					
			IEC B5						IEC B5					
			80	90	110-112	132	160	180	80	90	110-112	132	160	180
<b>160C</b>	50	23.13	24.26	24.13	24.27	27.47	31.89	34.91	25.33	27.71	27.88	42.74	44.92	90.19
	63	22.01	23.14	23.01	23.15	26.35	30.77	33.79	24.21	26.59	26.77	41.63	43.81	89.07
	80	21.76	22.89	22.76	22.90	26.10	30.52	33.54	23.96	26.34	26.51	41.37	43.56	88.82
	100	8.65	9.61	9.48	9.62	12.82	17.24	20.26	10.85	13.23	13.40	28.26	30.45	75.71
	125	8.35	9.30	9.17	9.31	12.51	16.94	19.95	10.54	12.92	13.10	27.96	30.14	75.41
	160	8.28	9.23	9.10	9.24	12.44	16.87	19.88	10.47	12.86	13.03	27.89	30.07	75.34
	200	8.26	9.21	9.09	9.22	12.42	16.85	19.87	10.46	12.84	13.01	27.87	30.05	75.32
	225*	8.25	9.20	9.08	9.21	12.41	16.84	19.86	10.44	12.83	13.00	27.86	30.04	75.31
	250	4.26	4.92	4.79	4.93	8.13	12.55	15.57	6.46	8.84	9.01	23.87	26.05	71.32
	315	4.24	4.90	4.77	4.91	8.11	12.53	15.55	6.44	8.82	9.00	23.86	26.04	71.30
	400	4.24	4.90	4.77	4.91	8.11	12.53	15.55	6.43	8.81	8.99	23.85	26.03	71.30
	450*	4.23	4.89	4.76	4.90	8.10	12.52	15.54	6.43	8.81	8.99	23.85	26.03	71.29
	500	4.17	4.83	4.70	4.84	8.03	12.46	15.48	6.36	8.74	8.92	23.78	25.96	71.23
	550*	4.16	4.82	4.69	4.83	8.03	12.46	15.47	6.36	8.74	8.92	23.78	25.96	71.22
	630	4.16	4.82	4.69	4.83	8.03	12.45	15.47	6.36	8.74	8.92	23.78	25.96	71.22

\* **Rapporti speciali / Special ratios / Sonderverhältnisse**

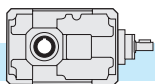







2.9 **Momenti d'inerzia** [Kg·cm<sup>2</sup>]  
(riferiti all'albero veloce in entrata)

2.9 **Moments of inertia** [Kg·cm<sup>2</sup>]  
(referred to input shaft)

2.9 **Trägheitsmoment** [Kg·cm<sup>2</sup>]  
(bez. Antriebswelle)

**TA..C - TC..C - TF..C**

	$i_n$	TA 	TC 						TF 					
			IEC B5						IEC B5					
			80	90	110-112	132	160	180	80	90	110-112	132	160	180
			<b>180C</b>	50	23.76	24.89	24.76	24.90	28.10	32.52	35.54	25.95	28.34	28.51
63	22.45	23.58		23.45	23.59	26.79	31.21	34.23	24.65	27.03	27.20	42.06	44.25	89.51
80	22.17	23.30		23.17	23.31	26.51	30.93	33.95	24.37	26.75	26.93	41.79	43.97	89.23
100	20.94	22.07		21.94	22.07	25.27	29.70	32.72	23.13	25.51	25.69	40.55	42.73	88.00
125	8.71	9.67		9.54	9.68	12.88	17.30	20.32	10.91	13.29	13.47	28.33	30.51	75.77
160	8.39	9.35		9.22	9.36	12.56	16.98	20.00	10.59	12.97	13.14	28.00	30.18	75.45
200	8.05	9.01		8.88	9.02	12.22	16.64	19.66	10.25	12.63	12.81	27.67	29.85	75.11
250	4.35	5.01		4.88	5.02	8.22	12.64	15.66	6.55	8.93	9.10	23.96	26.14	71.41
315	4.27	4.93		4.80	4.94	8.14	12.56	15.58	6.47	8.85	9.02	23.88	26.06	71.33
400	4.18	4.84		4.72	4.85	8.05	12.48	15.50	6.38	8.76	8.94	23.80	25.98	71.25

	$i_n$	TA 	TC 					TF 				
			IEC B5					IEC B5				
			110-112	132	160	180	200	110-112	132	160	180	200
			<b>200C</b>	40	72.31	74.90	80.58	79.58	82.49	92.88	91.93	93.29
50	71.70	74.28		79.97	78.97	81.87	92.26	91.31	92.68	94.86	143.98	140.50
63	71.11	73.69		79.38	78.38	81.28	91.67	90.72	92.09	94.27	143.39	139.91
80	70.63	73.22		78.90	77.90	80.81	91.20	90.24	91.61	93.79	142.91	139.43
100	26.74	29.50		35.19	34.19	37.09	47.48	46.35	47.72	49.90	99.02	95.54
125	26.58	29.34		35.03	34.02	36.93	47.32	46.19	47.56	49.74	98.86	95.38
160	26.45	29.21		34.90	33.89	36.80	47.19	46.06	47.43	49.61	98.73	95.25
200	12.17	14.44		20.12	19.12	22.03	32.42	31.78	33.15	35.33	84.45	80.97
250	12.13	14.40		20.09	19.08	21.99	32.38	31.74	33.11	35.29	84.41	80.93
315	12.09	14.37		20.05	19.05	21.96	32.35	31.71	33.07	35.25	84.37	80.90

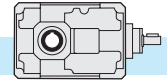

2.10 Dimensioni

2.10 Dimensions

2.10 Abmessungen

**TF56B...**

2 Riduzioni/Stages/Stufen

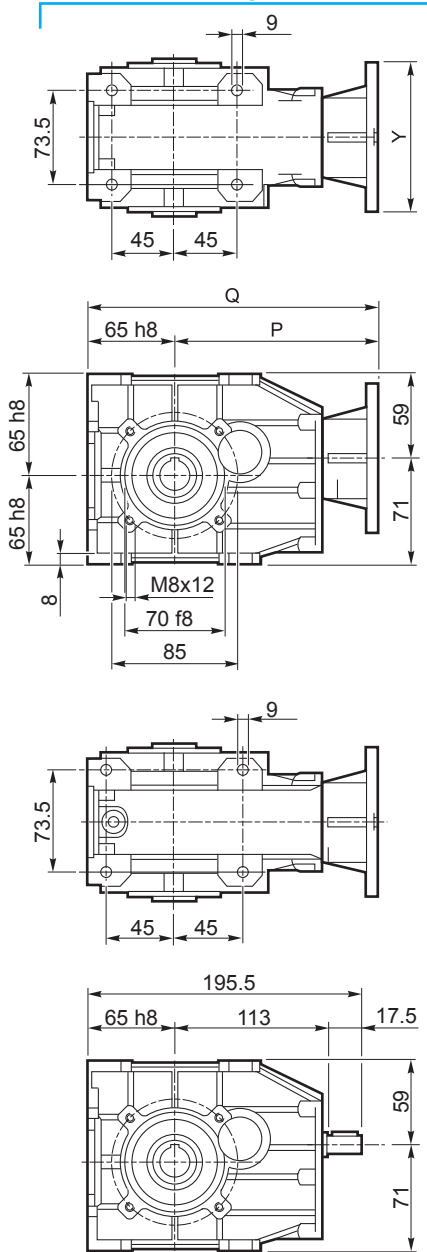





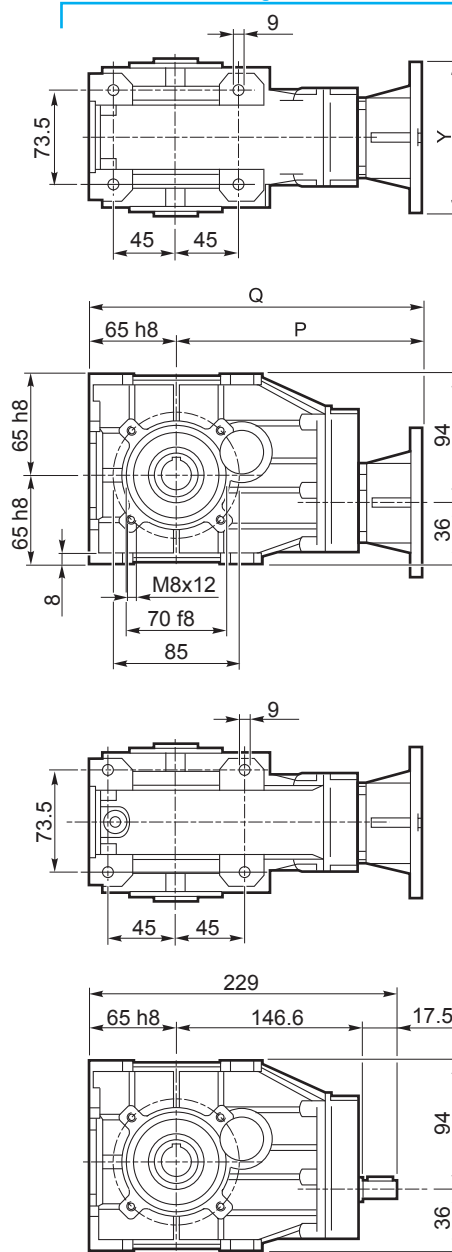

**TF56C...**

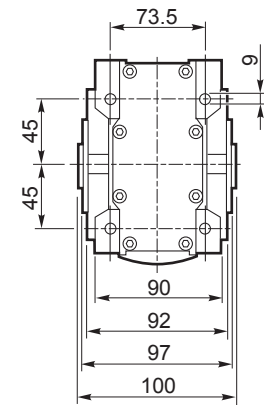
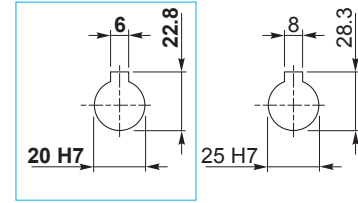
3 Riduzioni/Stages/Stufen



standard



IEC	
	56 B5
	63 B5
	71 B5
	80 B5/B14
	90 B5/B14

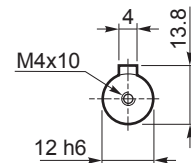

B5	TF...									
	56B					56C				
IEC..	56	63	71	80	90	56	63	71	80	90
Y	120	140	160	200	200	120	140	160	200	200
P	153	156	163	183	183	187	190	197	217	217
Q	218	221	228	248	248	252	255	262	282	282
kg	4.5	4.5	4.5	4.5	4.5	5.0	5.0	5.0	5.0	5.0

B14	TF...									
	56B					56C				
IEC..	56	63	71	80	90	56	63	71	80	90
Y	—	—	105	120	140	—	—	105	120	140
P	—	—	163	183	183	—	—	197	217	217
Q	—	—	228	248	248	—	—	262	282	282
kg	—	—	4.5	4.5	4.5	—	—	5.0	5.0	5.0

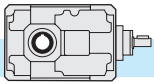

2.10 Dimensioni

2.10 Dimensions

2.10 Abmessungen

**TF63B...**

2 Riduzioni/Stages/Stufen

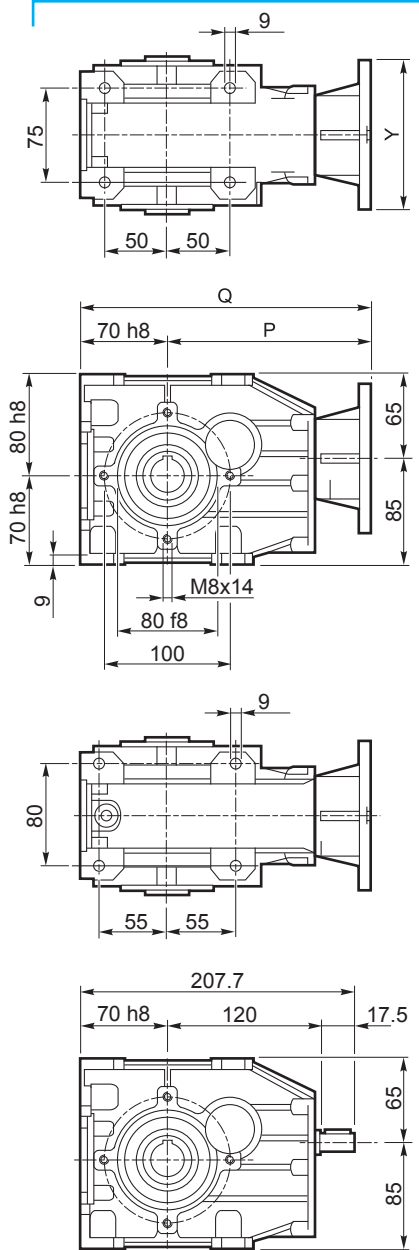

**TF63C...**

3 Riduzioni/Stages/Stufen

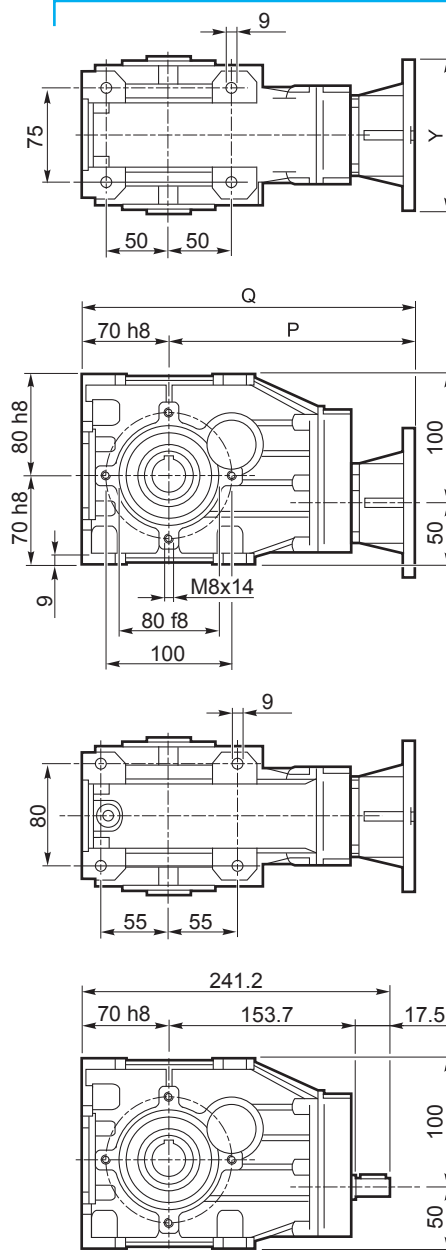

standard

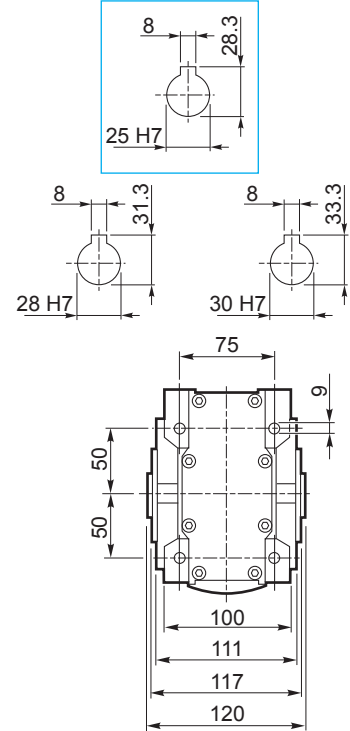

IEC	
	56 B5
	63 B5
	71 B5
	80 B5/B14
	90 B5/B14

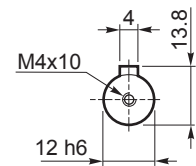

IEC..	TF...									
	63B					63C				
Y	120	140	160	200	200	120	140	160	200	200
P	160	163	170	190	190	194	197	204	224	224
Q	230	233	240	260	260	264	267	274	294	294
kg	6.0	6.0	6.0	6.0	6.0	6.5	6.5	6.5	6.5	6.5

IEC..	TF...									
	63B					63C				
Y	—	—	105	120	140	—	—	105	120	140
P	—	—	170	190	190	—	—	204	224	224
Q	—	—	240	260	260	—	—	274	294	294
kg	—	—	6.0	6.0	6.0	—	—	6.5	6.5	6.5

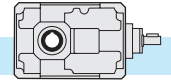

2.10 Dimensioni

2.10 Dimensions

2.10 Abmessungen

**TF75B...**

2 Riduzioni/Stages/Stufen

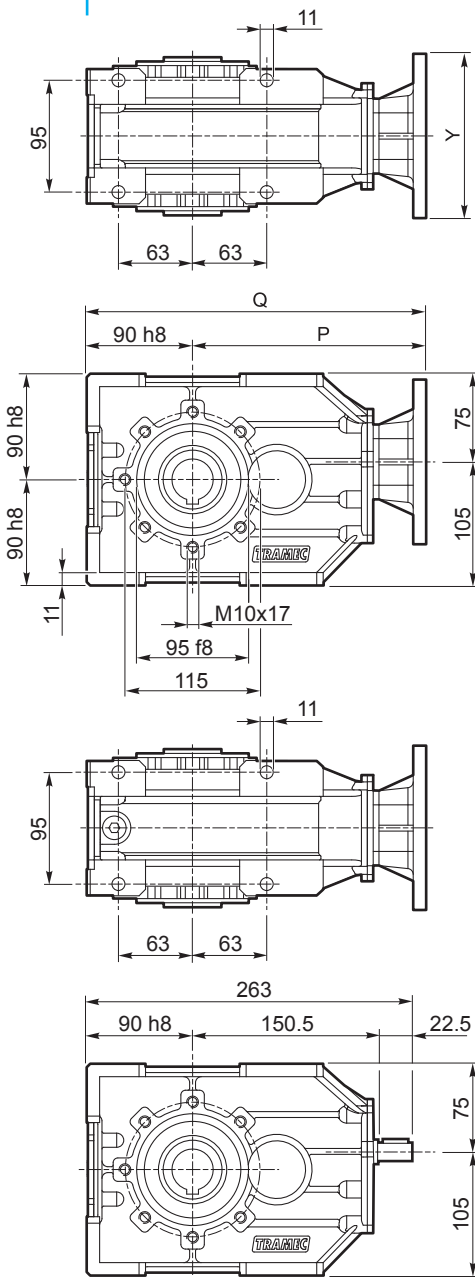

**TF75C...**

3 Riduzioni/Stages/Stufen

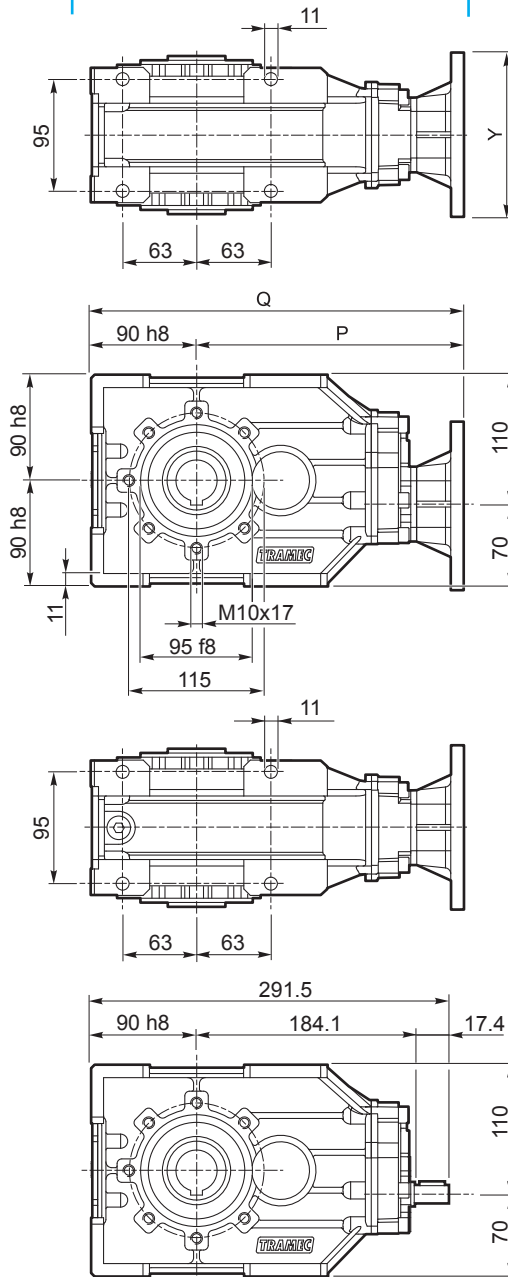

standard

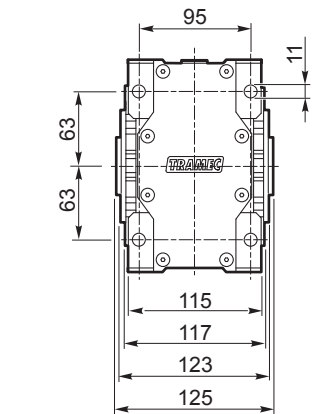
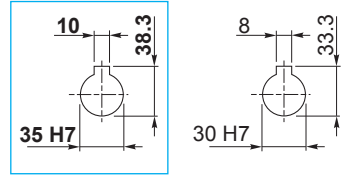

IEC	
	63 B5
71 B14	71 B5
	80 B5/B14
	90 B5/B14
	100 B5/B14

**TA75B... TA75C...**

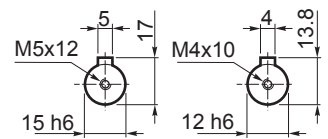

B5	TF...									
	75B					75C				
IEC..	71	80	90	100	112	63	71	80	90	
Y	160	200	200	250	250	140	160	200	200	
P	205.5	225.5	225.5	235.5	235.5	227	234	254	254	
Q	295.5	315.5	315.5	325.5	325.5	317	324	344	344	
kg	10	10	10	10	10	11	11	11	11	

B14	TF...									
	75B					75C				
IEC..	71	80	90	100	112	63	71	80	90	
Y	105	120	140	160	160	-	105	120	140	
P	205.5	225.5	225.5	235.5	235.5	-	234	254	254	
Q	295.5	315.5	315.5	325.5	325.5	-	324	344	344	
kg	10	10	10	10	10	-	11	11	11	

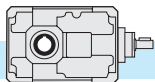

2.10 Dimensioni

2.10 Dimensions

2.10 Abmessungen

TA... - TC... - TF..																	
	71B			90B			112B			140B		180B		200B		225B	
A	142			180			224			280		360		400		450	
a	102			134			166			209		272.5		305		344	
a1	—			—			—			—		—		—		—	
B	112			127			150			175		215		255		290	
b	90			104			125			145		180		210		240	
C2	115			130			155			180		220		260		300	
D1 h6	14			19			24			28		38		38		48	
D2 H7	24	28	30	32	30	35	42	40	45	55	50	70	60	90	80	100	90
E	206			262			326			407		522.5		585		654	
e	38			52			64			82		110		120		140	
F	9			11			13			15		17		19		21	
f	M8x13			M10x16			M12x19			M14x22		M16x25		M18x35		M18x30	
G	122			155			194			244		320		350		400	
g	61			77.5			97			122		160		175		200	
H	71			90			112			140		180		200		225	
h	174			212			262			317		400		422.5		500	
I	110			130			160			190		237.5		237.5		296	
i	125			159.5			199			249		322.5		360		404	
L1	30			40			50			60		80		80		110	
O	64			82			102			127		162.5		185		204	
T	275			342			424			517		660		702.5		835	
t	211			260			322			390		497.5		517.5		631	
Z	9			11			13			16		20		22		25	

TA..														
kg	12.5		20		34		58		116		165		232	

TC... - TF...														
kg	15.5		25		44		75		136		185		270	

TC...												
	71B				90B				112B			
IEC	63 B5	71 B5	80/90 B5	80 B14	71 B5	80/90 B5	*90 B14	100/112 B5	80/90 B5	100/112 B5	132 B5	
Y	140	160	200	120	160	200	□ 120 / R73	250	200	250	300	
P	177	184	204	204	220	240	240	250	286	296	318	
p	113	120	140	140	138	158	158	168	184	194	216	
Q	248	255	275	275	310	330	330	340	398	408	430	
q	184	191	211	211	228	248	248	258	296	306	328	

	140B				180B				200B			
IEC	80/90 B5	100/112 B5	132 B5	160/180 B5	100/112 B5	132 B5	160/180 B5	200 B5	100/112 B5	132 B5	160/180 B5	200 B5
Y	200	250	300	350	250	300	350	400	250	300	350	400
P	331	341	363	393	413 / 423 (i=10-40) / (i=50-80)	433 / 443 (i=10-40) / (i=50-80)	463 / 473 (i=10-40) / (i=50-80)		435 / 445 (i=8-40) / (i=50-63)	455 / 465 (i=8-40) / (i=50-63)	485 / 495 (i=8-40) / (i=50-63)	
p	204	214	236	266	250 / 260 (i=10-40) / (i=50-80)	270 / 280 (i=10-40) / (i=50-80)	300 / 310 (i=10-40) / (i=50-80)		250 / 260 (i=8-40) / (i=50-63)	270 / 280 (i=8-40) / (i=50-63)	300 / 310 (i=8-40) / (i=50-63)	
Q	471	481	503	533	593 / 603 (i=10-40) / (i=50-80)	613 / 623 (i=10-40) / (i=50-80)	643 / 653 (i=10-40) / (i=50-80)		635 / 645 (i=8-40) / (i=50-63)	655 / 665 (i=8-40) / (i=50-63)	685 / 695 (i=8-40) / (i=50-63)	
q	344	354	376	406	430 / 440 (i=10-40) / (i=50-80)	450 / 460 (i=10-40) / (i=50-80)	480 / 490 (i=10-40) / (i=50-80)		450 / 460 (i=8-40) / (i=50-63)	470 / 480 (i=8-40) / (i=50-63)	500 / 510 (i=8-40) / (i=50-63)	

\* Flange quadrate / Square flanges / Viereckige Flansche

TF...													
	71B			90B			112B			140B			
IEC	63 B5	71 B5	80/90 B5	71 B5	80/90 B5	100/112 B5	80/90 B5	100/112 B5	132 B5	80/90 B5	100/112 B5	132 B5	160/180 B5
Y	140	160	200	160	200	250	200	250	300	200	250	300	350
P	231	238	259	286	307	317	367	377	398	432	442	463	493
p	167	174	195	204	225	235	265	275	296	305	315	336	366
Q	302	309	330	376	397	407	479	489	510	572	582	603	633
q	238	245	266	294	315	325	377	387	408	445	455	476	506

	180B				200B				225B				
IEC	100/112 B5	132 B5	160/180 B5	200 B5	100/112 B5	132 B5	160/180 B5	200 B5	225 B5	132 B5	160/180 B5	200 B5	225 B5
Y	250	300	350	400	250	300	350	400	450	300	350	400	450
P	546	566	596	596	568.5	588.5	618.5	620.5	648.5	698	728	728	758
p	393.5	403	433	433	383.5	403.5	433.5	435.5	466.5	494	524	524	554
Q	736	746	776	776	768.5	788.5	818.5	820.5	848.5	923	953	953	985
q	573.5	583	613	613	583.5	603.5	633.5	635.5	663.5	774	749	749	779

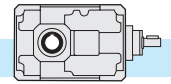

## T..71B - T..225B

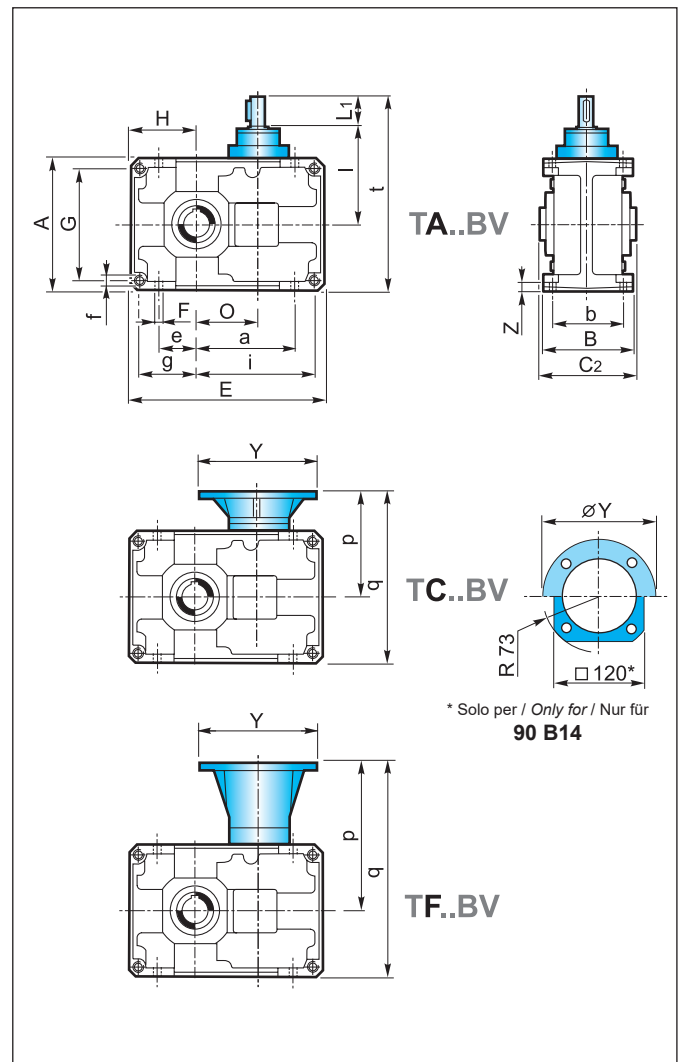
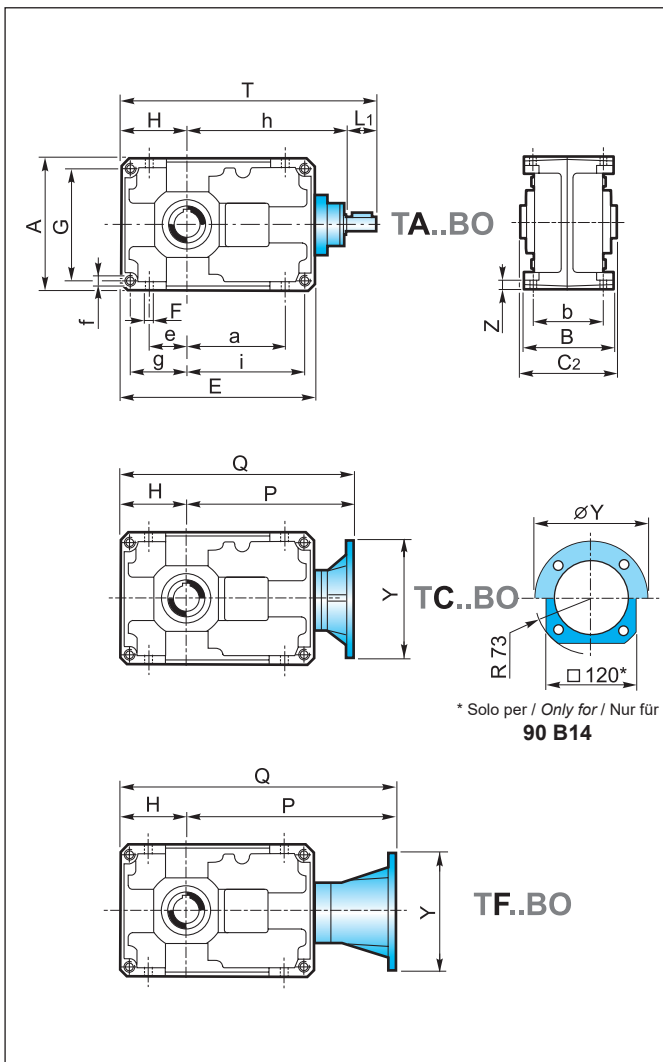

**Albero uscita cavo**  
*Hollow output shaft*  
**Abtriebshohlwelle**

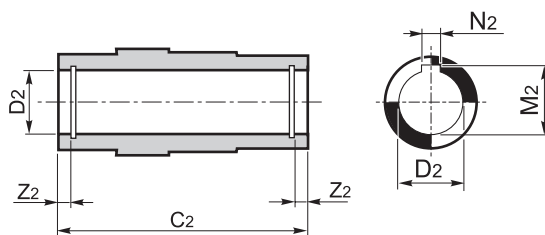

**Albero entrata**  
*Input shaft*  
**Antriebswelle**

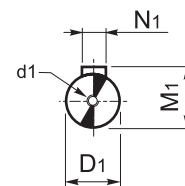

		TA... - TC... - TF...																
		71B			90B			112B			140B		180B		200B		225B	
<b>D1</b> h6		14			19			24			28		38		38		48	
<b>d1</b>		M4x15			M8x22			M8x22			M8x22		M10x28		M10x28		M12x34	
<b>M1</b>		16			21.5			27			31		41		41		51.5	
<b>N1</b>		5			6			8			8		10		10		14	
<b>C2</b>		115			130			155			180		220		260		300	
<b>D2</b> H7	<b>24</b>	28	30	<b>32</b>	30	35	<b>42</b>	40	45	<b>55</b>	50	<b>70</b>	60	<b>90</b>	80	<b>100</b>	90	
<b>M2</b>	27.3	31.3	33.3	35.3	33.3	38.3	45.3	43.3	48.8	59.3	53.8	74.9	64.4	95.4	85.4	106.4	95.4	
<b>N2</b>	8	8	8	10	8	10	12	12	14	16	14	20	18	25	22	28	25	
<b>Z2</b>	—			8.7	8.7	8.4	10.7	10.7	10.7	11.9	11.9	15.4	15.9	18.9	19.4	16.9	-	



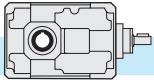

2.10 Dimensioni

2.10 Dimensions

2.10 Abmessungen

TA... - TC... - TF...														
80C			100C			125C		160C		180C		200C		
A	160			200			250		320		360		400	
a	82			102			127		162.5		185		204	
a1	106			134			169		217		207		277.5	
B	127			150			175		215		255		290	
b	104			125			145		180		210		240	
C2	130			155			180		220		260		300	
D1 h6	14			19			24		28		28		38	
D2 H7	32	30	35	42	40	45	55	50	70	60	90	80	100	90
E	306			384			479		609.5		652		766.5	
e	42			52			67		90		100		115	
F	11			13			15		17		19		21	
f	M10x16			M12x19			M14x22		M16x25		M18x35		M18x30	
G	135			170			214		280		310		350	
g	67.5			85			107		140		155		175	
H	80			100			125		160		180		200	
h	256			314			389		479.5		502		604	
I	110			130			160		190		190		237.5	
i	213.5			269			336		429.5		447		541.5	
L1	30			40			50		60		60		80	
O	146			184			229		289.5		312		366.5	
T	366			454			564		699.5		742		884	
t	220			270			335		410		430		517.5	
Z	11			13			16		20		22		25	

TA..												
kg	19		36		66		120		170		260	

TC... - TF...												
kg	22		41		76		137		190		295	

TC...											
80C				100C				125C			
IEC	63 B5	71 B5	80/90 B5	80 B14	71 B5	80/90 B5	*90 B14	100/112 B5	80/90 B5	100/112 B5	132 B5
Y	140	160	200	120	160	200	□ 120 / R 73	250	200	250	300
P	259	266	286	286	322	342	342	352	413	423	445
p	113	120	140	140	138	158	158	168	184	194	216
Q	339	346	366	366	422	442	442	452	538	548	570
q	193	200	220	220	238	258	258	268	309	319	341

160C				180C				200C				
IEC	80/90 B5	100/112 B5	132 B5	160/180 B5	80/90 B5	100/112 B5	132 B5	160/180 B5	100/112 B5	132 B5	160/180 B5	200 B5
Y	200	250	300	350	200	250	300	350	250	300	350	400
P	493	503	525	555	516	526	548	578	$\frac{617}{(i=40-160)} / \frac{627}{(i=200-315)}$	$\frac{637}{(i=40-160)} / \frac{647}{(i=200-315)}$	$\frac{667}{(i=40-160)} / \frac{677}{(i=200-315)}$	
p	204	214	236	266	204	214	236	266	$\frac{250}{(i=40-160)} / \frac{260}{(i=200-315)}$	$\frac{270}{(i=40-160)} / \frac{280}{(i=200-315)}$	$\frac{300}{(i=40-160)} / \frac{310}{(i=200-315)}$	
Q	653	663	686	715	696	706	728	758	$\frac{617}{(i=40-160)} / \frac{627}{(i=200-315)}$	$\frac{837}{(i=40-160)} / \frac{647}{(i=200-315)}$	$\frac{867}{(i=40-160)} / \frac{877}{(i=200-315)}$	
q	364	374	396	426	384	394	416	446	$\frac{450}{(i=40-160)} / \frac{460}{(i=200-315)}$	$\frac{470}{(i=40-160)} / \frac{480}{(i=200-315)}$	$\frac{500}{(i=40-160)} / \frac{510}{(i=200-315)}$	

\* Flange quadrate / Square flanges / Viereckige Flansche

TF...									
80C			100C			125C			
IEC	63 B5	71 B5	80/90 B5	71 B5	80/90 B5	100/112 B5	80/90 B5	100/112 B5	132 B5
Y	140	160	200	160	200	250	200	250	300
P	313	320	341	388	409	419	494	504	525
p	167	174	195	204	225	235	265	275	296
Q	393	400	421	488	509	519	619	629	650
q	247	254	275	304	325	335	390	400	421

160C				180C				200C				
IEC	80/90 B5	100/112 B5	132 B5	160/180 B5	80/90 B5	100/112 B5	132 B5	160/180 B5	100/112 B5	132 B5	160/180 B5	200 B5
Y	200	250	300	350	200	250	300	350	250	300	350	400
P	594	604	625	655	617	627	648	678	750	770	800	802
p	305	315	336	366	305	315	336	366	383.5	404	434	436
Q	754	764	785	815	797	807	828	858	950	970	1000	1002
q	465	475	496	526	485	495	516	546	583.5	604	634	636

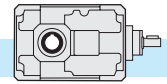

## T..80C - T..200C

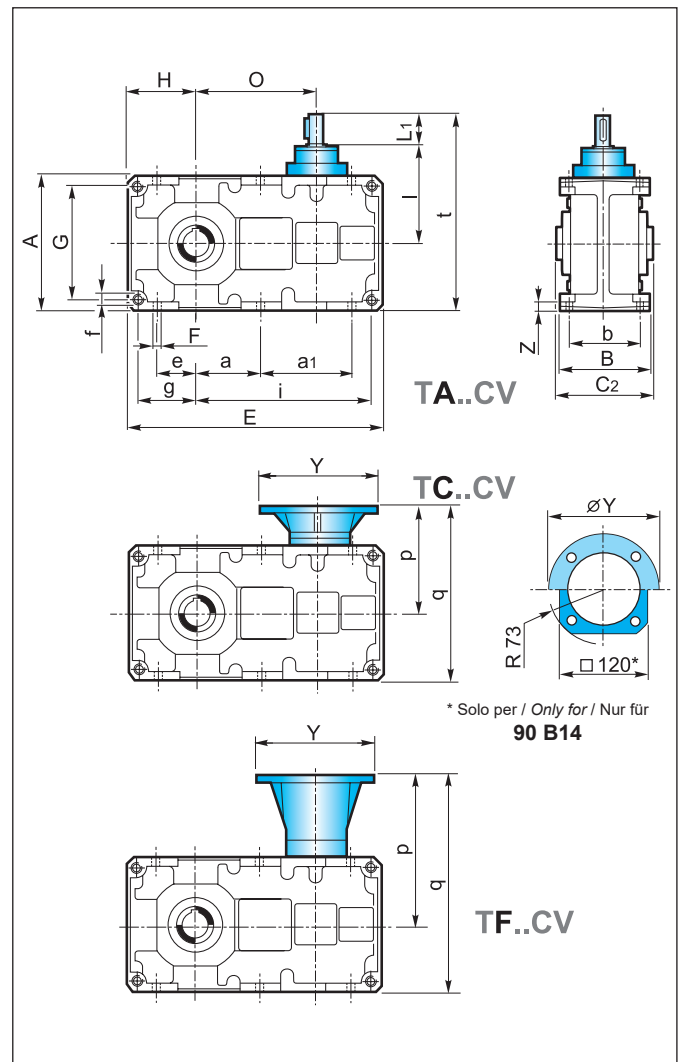
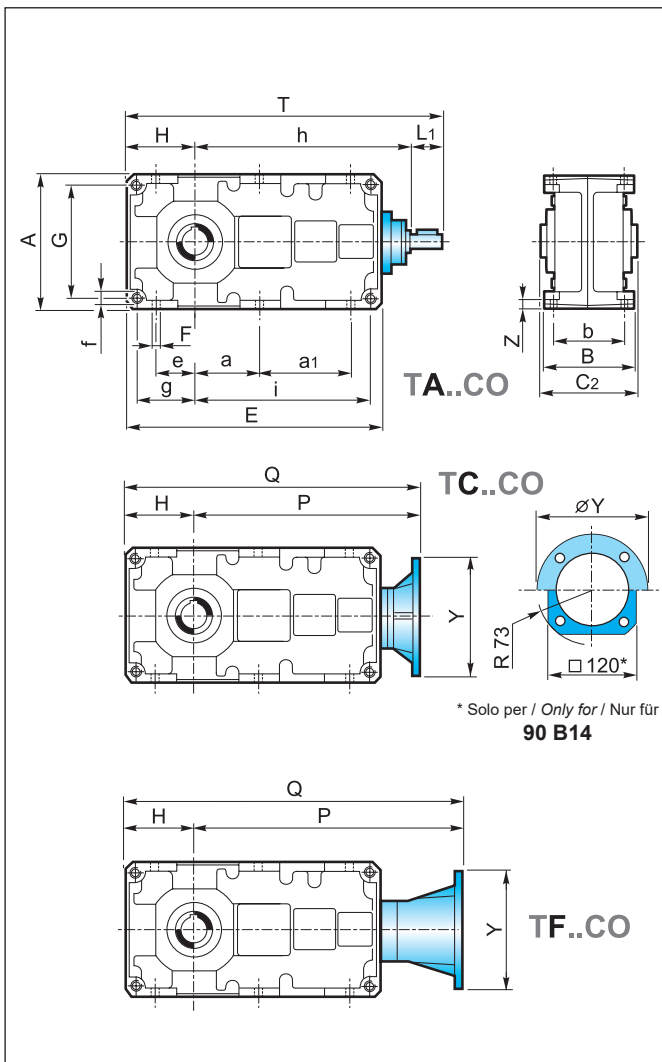

**Albero uscita cavo**  
*Hollow output shaft*  
**Abtriebshohlwelle**

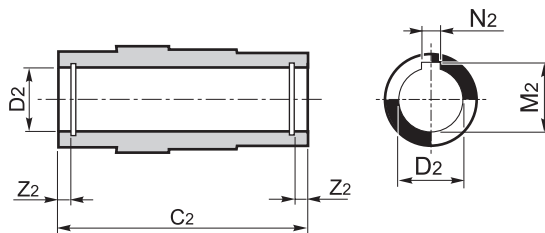

**Albero entrata**  
*Input shaft*  
**Antriebswelle**

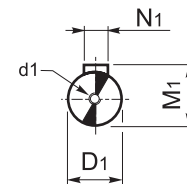

### TA... - TC... - TF...

	80C		100C			125C		160C		180C		200C		
<b>D1 h6</b>	14		19			24		28		28		38		
<b>d1</b>	M6x16		M8x22			M8x22		M8x22		M8x22		M10x28		
<b>M1</b>	16		21.5			27		31		31		41		
<b>N1</b>	5		6			8		8		8		10		
<b>C2</b>	130		155			180		220		260		300		
<b>D2 H7</b>	<b>32</b>	30	35	<b>42</b>	40	45	<b>55</b>	50	<b>70</b>	60	<b>90</b>	80	<b>100</b>	90
<b>M2</b>	35.3	33.3	38.3	45.3	43.3	48.8	59.3	53.8	74.9	64.4	95.4	85.4	106.4	95.4
<b>N2</b>	10	8	10	12	12	14	16	14	20	18	25	22	28	25
<b>Z2</b>	8.7		8.4		10.7		11.9		15.4		18.9		19.4	
													-	

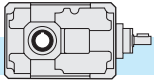

2.11 Accessori

2.11 Accessories

2.11 Zubehör

Albero lento

Output shaft

Abtriebswelle

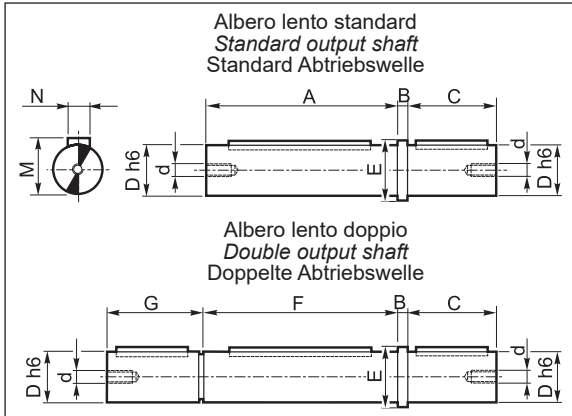

Materiale albero lento: C45  
Output shaft material: C45  
Material der Abtriebswelle: C45

	T											
	56B 56C	63B 63C	75B 75C	71B	90B 80C	112B 100C	140B 125C	180B 160C	200B 180C	225B 200C		
A	100	120	123	114	129	129	154	154	179	219	259	298
B	5	5	6	5	6	6	8	8	10	12	15	15
C	40	45	60	50	60	60	80	80	100	125	140	180
D <sub>h6</sub>	20	25	35	24	32	35	42	45	55	70	90	100
d	M8	M8	M10	M8	M8	M8	M10	M10	M10	M12	M16	M18
E	26	32	43	30	40	43	50	53	65	80	110	118
F	100	120	125	115	130	—	155	—	180	220	260	300
G	41	46	60	49	59	—	79	—	99	124	141	178
M	22.5	28	38	27	35	38	45	48.5	59	74.5	95	106
N	6	8	10	8	10	10	12	14	16	20	25	28

Kit fissaggio e smontaggio  
riduttori con albero lento cavo  
(escluso T 56, 63, 71 e 75)

Kit for the mounting and dismounting  
of the gearboxes with hollow output  
shaft (except T 56, 63, 71 and 75)

Kit für Montage und Ausbau der  
Getriebe mit Abtriebshohlwelle  
(außer dass T 56, 63, 71 und 75)

	T												
	90B 80C			112B 100C			140B 125C		180B 160C		200B 180C		225B 200C
C2	130			155			180		220		260		300
D2	32	30	35	42	40	45	55	50	70	60	90	80	100
H	8	7	6.5	10	8		9		12		16	15.5	17
d1	—			—			M10		M12		M16		M18
d2	—			—			M8		M10		M12		M16
d3	M8			M8			—		—		—		—
d4	M12			M12			—		—		—		—
Z2	8.7		8.4	10.7			11.9		15.4	15.9	18.9	19.4	16.9
Lmax	111	112		131	133		156		189		221		262
Lmin	106	107		126	128		149		182		211		252

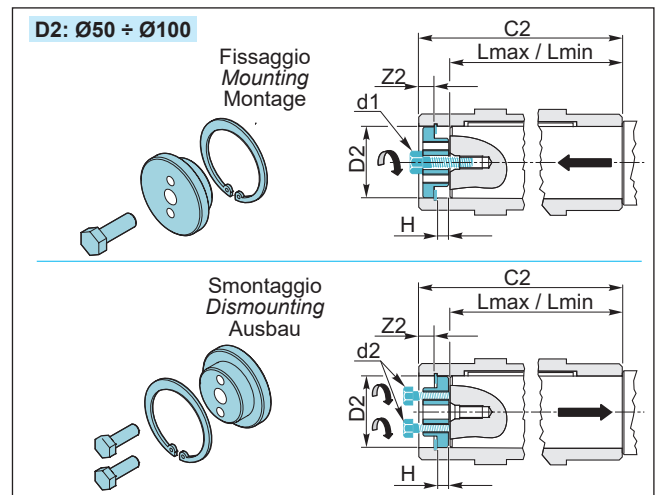
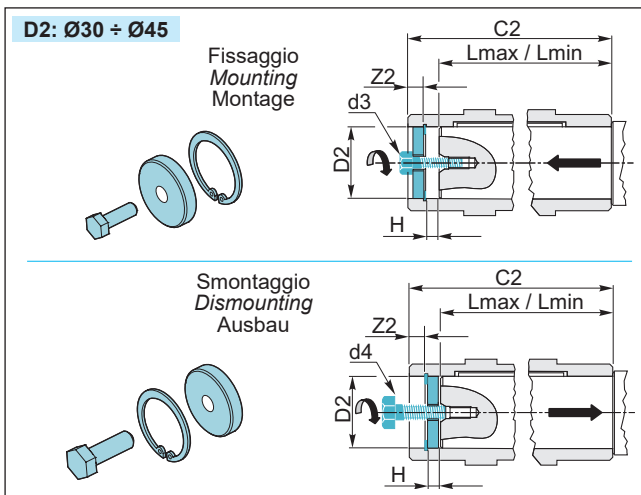

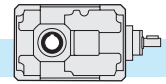

**Albero lento cavo con calettatore**

**Hollow output shaft with shrink disc**

**Abtriebshohlwelle mit Schrumpfscheibe**

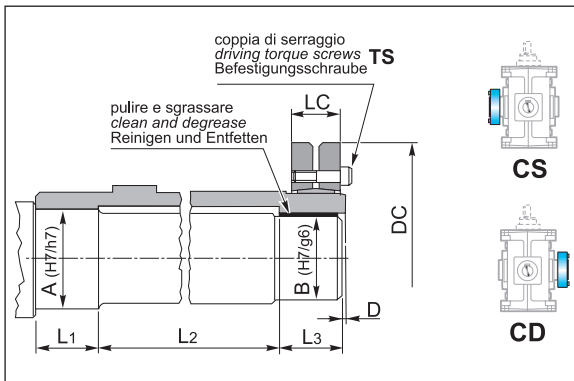

	T									
	56B 56C	63B 63C	75B 75C	71B	90B 80C	112B 100C	140B 125C	180B 160C	200B 180C	225B 200C
A	27	32	37	27	37	47	57	72	92	102
B	25	30	35	25	35	45	55	70	90	100
D	2	2	2	2	2	2	2	2	3	3
DC	60	72	80	60	80	100	115	155	188	215
LC	21.5	23.5	26	22	26	31	31	39	50	54
L <sub>1</sub>	32	36	39	36	39	45	50	60	70	80
L <sub>2</sub>	61	75	82	68	82	100	115	143	175	200
L <sub>3</sub>	32	36	39	36	39	45	50	60	70	80
TS(Nm)	4	12	12	4	12	12	12	30	59	59

**Flangia uscita**

**Output flange**

**Abtriebsflansch**

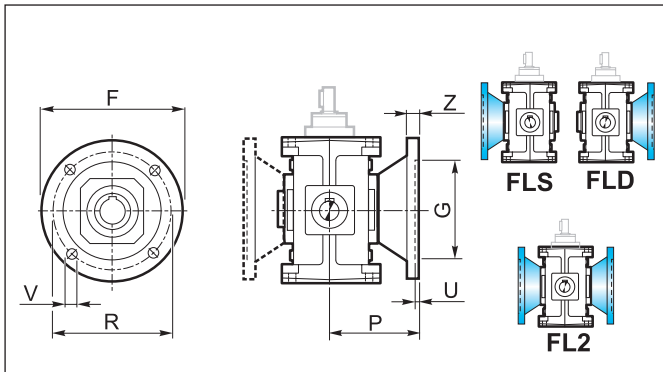

	T								
	56B 56C	63B 63C	75B 75C	71B	90B 80C	112B 100C	140B 125C	180B 160C	200B 180C
F	140	160	200	160	200	250	300	350	400
G <sub>F7</sub>	95	110	130	110	130	180	230	250	300
R	115	130	165	130	165	215	265	300	350
P	82	91.5	97.5	87	100	125	150	180	215
U	5	5	5	4	4.5	5	5	6	6
V	9	9	12	12	12	14	16	18	20
Z	15	10	15	10	12	16	20	25	30
kg	0.5	0.5	0.9	2	3.2	5	8	12.5	24

**Braccio di reazione**

**Torque arm**

**Drehmomentstütze**

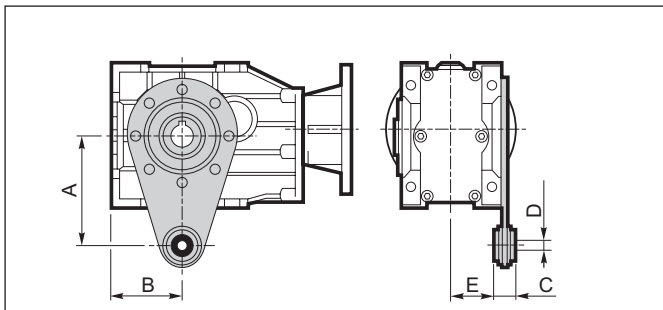

56B - 56C - 63B - 63C - 75B - 75C			
	T		
	56B 56C	63B 63C	75B 75C
A	100	150	200
B	65	70	90
C	20	20	25
D	10	10	20
E	39	48.5	49

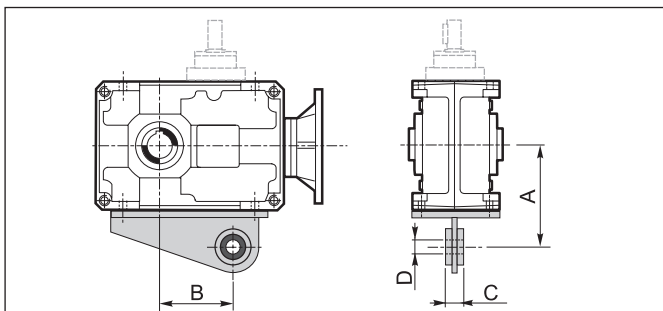

71B - 225B							
	T						
	71B	90B	112B	140B	180B	200B	225B
A	123	140	172	205	260	300	325
B	84	116	144	189	247.5	280	319
C	25	25	30	30	35	45	45
D	20	20	25	25	35	40	40

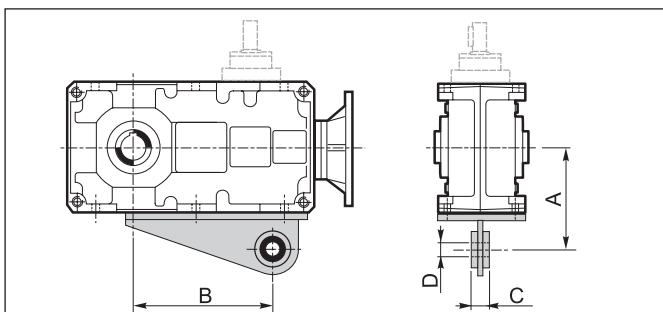

80C - 200C						
	T					
	80C	100C	125C	160C	180C	200C
A	130	160	190	240	280	300
B	170	214	276	354.5	367	456.5
C	25	30	30	35	45	45
D	20	25	25	35	40	40

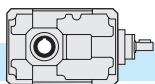

### Kit protezione albero cavo

Ad esclusione delle grandezze 56, 63 e 75, a richiesta è possibile predisporre il riduttore con un kit di protezione dell'albero cavo. Tale protezione, essendo dotata di un'opportuna guarnizione, impedisce ad eventuali fluidi, presenti nell'ambiente di lavoro, di venire a contatto con l'albero cavo del riduttore oltre ad impedire il contatto con corpi estranei. Le dimensioni di ingombro sono riportate nella tabella seguente.

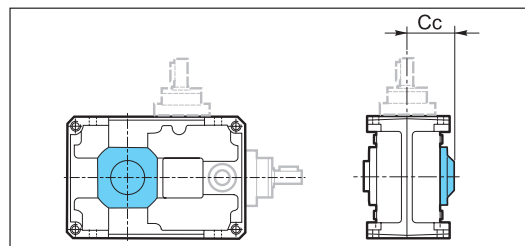

### Dispositivo antiritorno

Il riduttore ad assi ortogonali presenta valori di rendimento statico (e dinamico) molto elevati: per questo motivo non è garantita spontaneamente l'irreversibilità statica. L'irreversibilità statica si realizza quando, a riduttore fermo, l'applicazione di un carico all'albero lento non pone in rotazione l'asse entrata. Pertanto, per garantire l'irreversibilità del moto, a riduttore fermo, occorre predisporre il riduttore stesso con un opportuno dispositivo antiritorno, fornibile a richiesta tranne che sulle grandezze T56, T63 e T75. Tale dispositivo permette la rotazione dell'albero lento solo nel senso desiderato, da specificare all'atto dell'ordine.

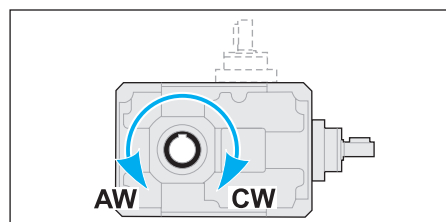

**Nel caso in cui sia presente il dispositivo antiritorno è necessario l'utilizzo di olio lubrificante sintetico, classe di viscosità ISO 150.**

Nella tabella seguente (tab. 3) sono indicati i valori dei momenti torcenti nominali massimi ( $T_{2Mmax}$ ), riferiti all'albero uscita, garantiti dal dispositivo di antiritorno, per ogni rapporto di riduzione e per ogni grandezza di riduttore. Se, in corrispondenza dell'albero lento, viene applicata una coppia maggiore di quella indicata, l'irreversibilità del moto non è più garantita. Questi valori di coppia non sono da confondere con quelli riportati nella tabella riguardante i dati tecnici dei riduttori. Infatti, si noti come in tabella siano stati messi in evidenza i valori di coppia garantiti (in uscita) dal dispositivo antiretro che risultano essere minori dei massimi valori di coppia motrice trasmissibili, con fattore di servizio  $F_s = 1$ , dal riduttore.

**Vedere paragrafo 1.5 per la verifica del dispositivo antiritorno.**

### Hollow shaft protection kit

*On request we can supply a hollow shaft protection kit (except for sizes 56, 63 and 75).*

*The kit features a gasket which prevents any contact between hollow shaft and foreign bodies or fluids existing in the working environment. Over-all dimensions are reported in the following table.*

Cc	T						
	71B	90B 80C	112B 100C	140B 125C	180B 160C	200B 180C	225B 200C
	79.5	87	105	120.5	141.5	167.5	191.5

### Backstop device

*Bevel helical gearboxes feature quite high values of static (and dynamic) efficiency: for this reason spontaneous static irreversibility is not guaranteed. Static irreversibility, with motionless gearbox, occurs when the application of a load on the output shaft does not cause rotation of the input axis. In order to guarantee motion irreversibility, with motionless gearbox, it is necessary to fit a backstop device, which is available on request, except for sizes 56, 63 and 75.*

*The backstop device enables rotation of the output shaft only in the required direction, which is to be specified when ordering.*

**CW** Rotazione oraria  
Clockwise rotation  
Im Uhrzeigersinn

**AW** Rotazione antioraria  
Anti-clockwise rotation  
Gegen den Uhrzeigersinn

**The utilization of synthetic oil, viscosity class ISO 150, is necessary for the gearboxes equipped with back stop device.**

*The following table (tab.3) shows the max. rated torques ( $T_{2Mmax}$ ) at gearbox output guaranteed by the backstop device, for each ratio and each gearbox size. If a higher torque is applied at gearbox output, motion irreversibility is no longer guaranteed.*

*These torque values are not to be confused with the values reported in the gearbox specifications tables.*

*Please note that the torque values guaranteed (at output) by the backstop device are lower than the max. driving torque values transmissible by the gearbox, with service factor  $F_s = 1$ .*

**To check the back stop device pls see paragraph 1.5.**

### Schutzvorrichtung für die Hohlwelle

Auf Wunsch ist eine Schutzvorrichtung für die Hohlwelle lieferbar (Größen 56, 63 und 75 ausgenommen).

Die Schutzvorrichtung weist eine Dichtung auf, die zur Vermeidung von irgendwelchem Kontakt zwischen Hohlwelle und Fremdkörper oder Flüssigkeiten der Arbeitsumgebung dient. Den Tabelle wird der Raumbedarf angegeben.

### Rücklaufsperre

Kegelstirnradgetriebe haben sehr hohen statischen (und dynamischen) Wirkungsgrad: deshalb wird keine spontane statische Irreversibilität garantiert. Statische Irreversibilität bei stillstehenden Getriebe hat man, wenn die Applikation mit einer Last auf die Abtriebswelle keine Drehung der Antriebswelle verursacht. Um Irreversibilität der Bewegung bei stillstehendem Getriebe zu sichern, sollte eine Rücklaufsperre montiert werden. Die Rücklaufsperre wird auf Wunsch geliefert (Größen 56, 63 und 75 ausgenommen). Die Rücklaufsperre ermöglicht, dass die Abtriebswelle nur in der gewünschten Richtung dreht (gewünschte Richtung beim Bestellen angeben).

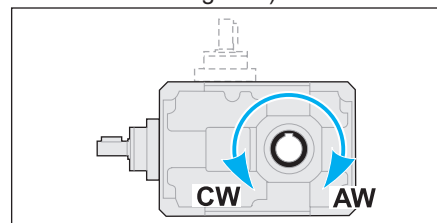

**Getriebe mit einer Rücklaufsperre müssen mit synthetischem Öl (Viskosität ISO150) betrieben werden.**

In der folgenden Tabelle (Tab. 3) werden die max. Nenndrehmomente am Abtrieb angegeben ( $T_{2Mmax}$ ), die die Rücklaufsperre je nach Übersetzungsverhältnis und Getriebegröße garantiert. Falls am Abtrieb ein höheres Drehmoment eingesetzt wird, dann ist die Irreversibilität der Bewegung nicht mehr garantiert.

Diese Drehmomente sind nicht mit den Werten zu verwechseln, die in der Tabelle der technischen Daten der Getriebe angegeben werden.

Die von der Rücklaufsperre (am Abtrieb) garantierten Drehmomente sind niedriger als die von den Getrieben übersetzbaren max. Drehmomente, unter Berücksichtigung eines Betriebsfaktors  $F_s = 1$ .

**Überprüfung der Rücklaufsperre siehe Abschnitt 1.5.**

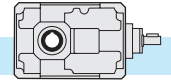

**Coppia massima garantita in uscita dal dispositivo antiritorno**  
**Max. output torque guaranteed by the backstop device**  
**Von der Rücklaufsperrre garantierten max. Abtriebsdrehmomente**

Tab. 3

T	in																
	5*	6.3*	7*	8	10	12.5	16	18*	20	25	31.5	35*	40	50	63	70*	80
	<b>T<sub>2M</sub> max [Nm]</b>																
<b>71B</b>	—	—	—	—	213	272	325	—	213	271	325	—	421	272	325	—	421
<b>90B</b>	148	204	—	—	333	424	508	—	333	424	508	—	657	424	508	—	657
<b>112B</b>	326	—	—	—	733	934	1118	—	733	933	1119	—	1446	933	1118	—	1446
<b>140B</b>	—	—	1038	—	1547	1969	2358	2630	1547	1968	2359	2630	3051	1968	2359	2630	3050
<b>180B</b>	—	—	—	—	3009	3831	4588	5115	3009	3829	4589	5115	5935	3829	4589	5115	5934
<b>200B</b>	—	—	—	5937	7607	9189	11399	—	12873	9190	11402	—	12875	11401	12875	—	—
<b>225B</b>	—	—	—	9856	11829	14538	9858	—	11838	14536	14537	—	17800	—	—	—	—

T	in															
	40	50	63	80	100	125	160	200	225*	250	315	400	450*	500	550*	630
	<b>T<sub>2M</sub> max [Nm]</b>															
<b>80C</b>	—	1086	1301	1656	1086	1301	1656	1985	—	1301	1656	1985	—	2567	—	3319
<b>100C</b>	—	1697	2033	2588	1697	2033	2588	3101	—	2033	2588	3101	—	4010	—	5186
<b>125C</b>	—	3733	4474	5694	3733	4473	5693	6822	7605	4473	5693	6822	7605	8822	9836	11410
<b>160C</b>	—	7874	9435	12008	7873	9435	12008	14388	16042	9434	12008	14388	16042	18607	20747	24064
<b>180C</b>	—	7874	9435	12008	7873	9435	12008	14388	—	9434	12008	14388	—	18607	—	24064
<b>200C</b>	12511	15024	18453	22586	15023	18450	22594	15024	—	18452	22594	—	—	—	—	—

\* Rapporti speciali / *Special ratios* / Sonderverhältnisse

Valori di coppia garantiti inferiori alla T<sub>2M</sub>

*Torque values guaranteed lower than T<sub>2M</sub> value*

Zuverlässige Drehmomente unter T<sub>2M</sub> Wert

Dimensioni riferite alla versione con antiretro

*Dimensions of the version with backstop device*

Abmessungen der Version mit Rücklaufsperrre

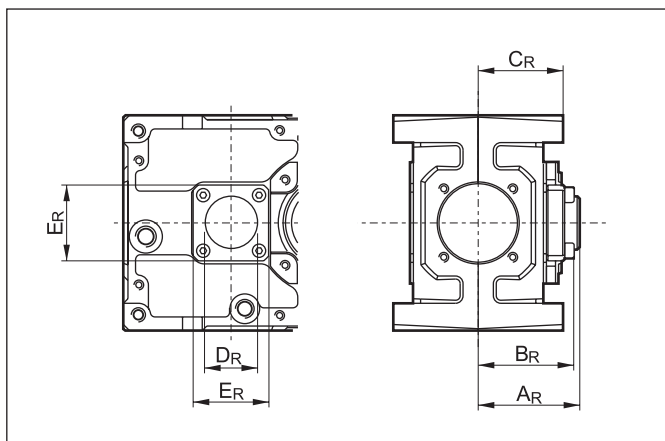

	A <sub>R</sub>	B <sub>R</sub>	C <sub>R</sub>	D <sub>R</sub>	E <sub>R</sub>
<b>T 71B</b>	67	63	56	35	50
<b>T 80C</b>	67	63	63.5	45	60
<b>T 90B</b>	73	68	63.5	45	60
<b>T 100C</b>	71.5	70	75	55	80
<b>T 112B</b>	90	83	75	55	80
<b>T 125C</b>	86.5	96.5	87.5	60	90
<b>T 140B</b>	108	95	87.5	70	90
<b>T 160C</b>	106.5	101	107.5	70	100
<b>T 180B</b>	122	113	107.5	80	110
<b>T180C</b>	110.5	110	127.5	70	100
<b>T200B</b>	163	137.5	127.5	90	160
<b>T 200C</b>	125	124	145	90	130
<b>T 225B</b>	169	147	145	110	155

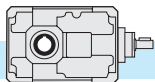

### 2.12 Giochi angolari

Bloccando l'albero di entrata, il gioco viene misurato sull'albero uscita ruotandolo nelle due direzioni ad applicando la coppia strettamente necessaria a creare il contatto tra i denti degli ingranaggi, al massimo pari al 2% della coppia massima garantita dal riduttore ( $T_{2M}$ ).

Nella tabella seguente sono riportati i valori indicativi del gioco angolare (in minuti di angolo) per quanto riguarda il montaggio normale. I valori ottenibili con una registrazione più precisa sono di poco inferiori di uno o due primi. Quest'ultima esecuzione è da utilizzare solo in caso di reale necessità in quanto potrebbe comportare un leggero aumento della rumorosità e rendere meno efficace l'azione dell'olio lubrificante.

### 2.12 Angular backlash

*After having blocked the input shaft the angular backlash can be measured on the output shaft by rotating it in both directions and applying the torque which is strictly necessary to create a contact between the teeth of the gears. The applied torque should be at most 2% of the max. torque guaranteed by the gearbox. ( $T_{2M}$ ). The following table reports the approximate values of the angular backlash (in minutes of arc) referred to standard mounting. The values that can be obtained with a more precise recording are slightly lower than one or two primes or two minutes of arc. The latter solution should be adopted only in case of necessity because it may rise the noise level and lessen the action of the lubricant.*

### 2.12 Winkelspiel

Nachdem die Antriebswelle blockiert worden ist, darf das Winkelspiel auf die Abtriebswelle bemessen werden. Dabei soll die Abtriebswelle in beiden Richtungen gedreht und ein Drehmoment ausgeübt werden, dass zur Entstehung eines Kontaktes zwischen den Zähnen genügt. Das ausgeübte Drehmoment soll höchstens 2% des max. vom Getriebe garantierten Drehmoment ( $T_{2M}$ ) sein.

Die folgende Tabelle weist die Näherungswerte des Winkelspiels (in Bogenminuten) für Standardmontage. Die mit einer genaueren Feineinstellung erhältlichen Werte sind um wenig geringer als 1 oder 2 Winkelminuten. Die präzise Lösung darf nur im Notfall angewendet werden, weil infolgedessen der Geräuschpegel zunimmt und die Wirkung des Schmiermittels abnimmt.

T	Gioco angolare massimo / Maximum Backlash / maximales Winkelspiel (1')
56B / 56C / 63B / 63C / 75B / 75C 71B / 90B / 80C / 112B / 100C	20'
140B / 125C / 180B / 160C / 200B / 180C / 225B / 200C	15'

### 2.13 Lubrificazione

I riduttori ad assi ortogonali ( ad esclusione dei tipi T56, T63 e T75, con lubrificazione a vita) sono forniti predisposti per lubrificazione a olio e muniti dei tappi di carico, livello e scarico olio.

Si raccomanda di precisare sempre la posizione di montaggio desiderata in fase di ordine.

#### POMPA DI LUBRIFICAZIONE.

Una pompa per lubrificazione forzata dei cuscinetti superiori è fornita a richiesta sulle grandezze 112, 125, 140, 160, 180, 200 e 225 nella posizione di montaggio VA.

Nelle posizioni di montaggio in cui sono presenti cuscinetti posti al di sopra del livello dell'olio lubrificante è prevista l'applicazione di grasso speciale su tali cuscinetti per migliorarne la lubrificazione. E' possibile dotare gli stessi cuscinetti di un anello metallico (nylos) con la funzione di contenimento del grasso e, di conseguenza, di prolungare l'effetto nel tempo. Questa soluzione viene fornita su specifica richiesta.

### 2.13 Lubrication

*Bevel helical gearboxes (except for T56, T63 and T75 which are lubricated for life) require oil lubrication and are equipped with filler, level and drain plugs.*

*The mounting position should always be specified when ordering the gearbox.*

#### OIL PUMP.

*A pump for forced lubrication of the upper bearings is supplied on request for sizes 112, 125, 140, 160, 180, 200 and 225 in the VA mounting position.*

*Depending on the mounting position, the bearings may be lodged above the lubricant level. In this case it is necessary to apply special grease on the bearings in order to improve their lubrication. A metallic ring (nylos) can be fitted on the bearings it keeps the grease in place thus prolonging the action. It is supplied on specific request.*

### 2.13 Schmierung

Die Kegelstirnradgetriebe sind für die Ölschmierung mit Einfüll-, Ölstand- und Ablassstopfen versehen.

Bei der Bestellung ist immer die gewünschte Montageposition anzugeben.

#### ÖLPUMPE.

Eine Pumpe für die Zwangsschmierung der oberen Lager kann auf Wunsch bei den Größen 112, 125, 140, 160, 180, 200 und 225 in der Montageposition VA geliefert werden.

Abhängig von der Einbaulage kann es sein, dass die Lager über dem Ölstand liegen. In dem Fall wird Sonderfett auf die Lager geschmiert, um deren Schmierung zu verbessern. Ein metallischer Ring (nylos) für die Lager kann auf Wunsch geliefert werden: er hält das Fett fest und verlängert die Lebensdauer.

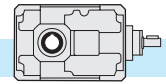

**Posizione di montaggio e quantità di lubrificante (litri)**

I quantitativi di olio riportati nelle varie tabelle sono indicativi e riferiti alle posizioni di lavoro indicate e considerando le condizioni di funzionamento a temperatura ambiente e velocità in ingresso di 1400 min<sup>-1</sup>. Per condizioni di lavoro diverse da quelle sopra riportate contattare il servizio tecnico.

**Mounting positions and lubricant quantity (liters)**

The oil quantities stated in the tables are approximate values and refer to the indicated working positions, considering operating conditions at ambient temperature and an input speed of 1400 min<sup>-1</sup>. Should the operating conditions be different, please contact the technical service.

**Montageposition und Ölmenge (liter)**

Die in der Tabellen angegebenen Daten sind Richtwerte. Die Ölmengen beziehen sich auf die angegebenen Betriebspositionen. Dabei wird den Betrieb bei Umgebungstemperatur und Antriebsdrehzahl von 1400 min<sup>-1</sup> berücksichtigt. Falls die Betriebsbedingungen anders sind, dann ist das technische Büro zu befragen.

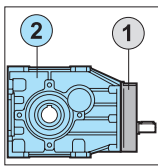
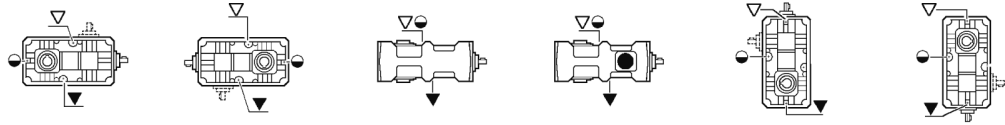

	T	B3	B8	B6	B7	VA	VB
②	56B			0.30		0.40	0.30
①	56C				0.05		
②	56C					0.40	0.30
②	63B			0.30		0.45	0.35
①	63C				0.05		
②	63C			0.35		0.45	0.35
②	75B				0.45		
①	75C				0.08		
②	75C				0.45		
	71B	0.6		0.7	0.5		0.8
	80C	1.1		1.5	1.3		1.5
	90B	1.0		1.4	1.2		1.3
	100C	2.0		2.6	2.3		2.8
	112B	1.8		2.6	2.3		2.4
	125C	3.8		4.8	4.5		5.0
	140B	3.6		4.6	4.3		4.3
	160C	7.0		9.2	8.7		10.0
	180B	7.5		9.7	9.2		8.0
	180C	9.5		14.0	13.0		15.5
	200B	12.5		15.0	14.0		17.5
	200C	13.5		19.0	18.0		19.5
	225B	14.5		19.0	18.0		18.7

\* Nella posizione di montaggio B6-B7 è previsto un tappo di sfiato con asta di livello, tranne T 56, 63 e 75.  
 \* In mounting position B6-B7 the breather plug is supplied complete with the dipstick, except T 56, 63 and 75.  
 \* Für die Version B6-B7 ist eine Entlüftungsschraube mit Ölstandsanzeige vorgesehen, außer dass T 56, 63 und 75.

**Posizione morsetti**

**Terminal board position**

**Lage des Klemmenkastens**

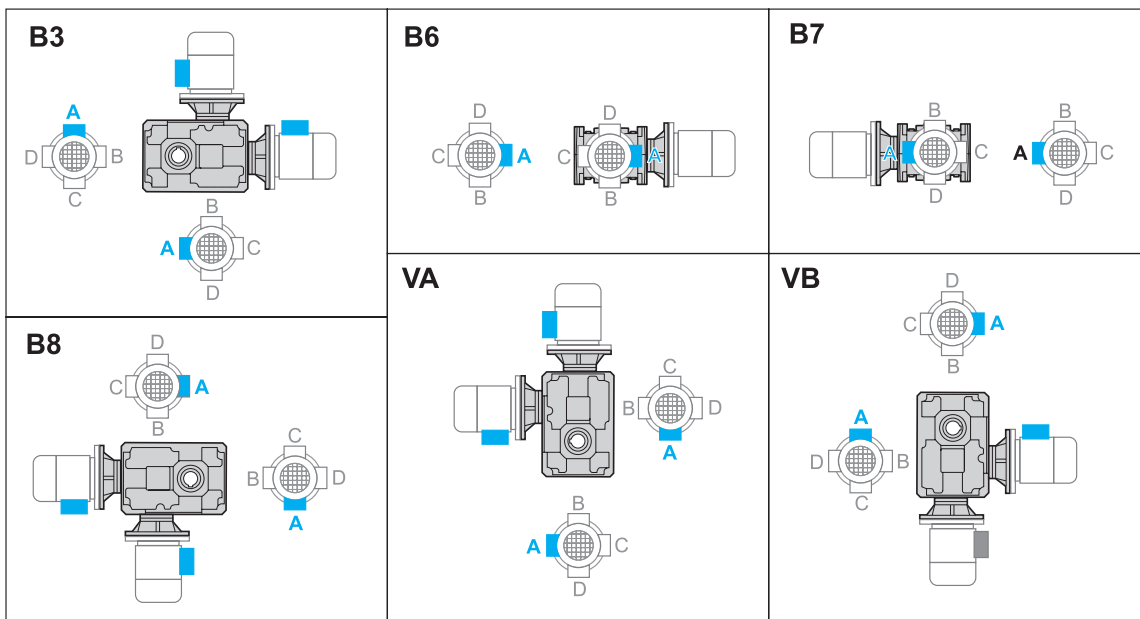

N.B. Se non diversamente specificato, il motore verrà fornito con la morsetti in posizione A.

N.B. Unless otherwise agreed, the motor will be supplied with the terminal board in position A..

ANMERKUNG: Ausser wenn anders angegeben, wird der Motor mit Klemmenkasten in der A Position geliefert.



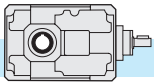

## 2.14 Carichi radiali e assiali (N)

Le trasmissioni effettuate tramite pignoni per catena, ruote dentate o pulegge generano delle forze radiali ( $F_R$ ) sugli alberi dei riduttori. L'entità di tali forze può essere calcolata con la formula:

## 2.14 Radial and axial loads (N)

*Transmissions implemented by means of chain pinions, wheels or pulleys generate radial forces ( $F_R$ ) on the gear unit shafts. The entity of these forces may be calculated using the following formula:*

## 2.14 Radial- und Axialbelastungen (N)

Antriebe mit Kettenritzel, Zählrädern oder Riemscheiben erzeugen radiale Kräfte ( $F_R$ ) an den Wellen der Untersetzungsgetriebe. Das Ausmaß dieser Kräfte kann nach folgender Formel berechnet werden:

$$F_R = \frac{K_R \cdot T}{d} \text{ [N]}$$

dove:

T = Momento torcente [Nm]  
d = Diametro pignone o puleggia [mm]

$K_R$  = 2000 per pignone per catena  
= 2500 per ruote dentate  
= 3000 per puleggia con cinghie a V

where:

T = torque [Nm]  
d = pinion or pulley diameter [mm]

$K_R$  = 2000 for chain pinion  
= 2500 for wheel  
= 3000 for V-belt pulley

dabei ist:

T = Drehmoment [Nm]  
d = Kettenritzel- bzw. Riemscheiben  
durchmesser [mm]

$K_R$  = 2000 bei Kettenritzel  
= 2500 bei Zahnrad  
= 3000 bei Riemscheibe mit  
Keilriemen

I valori dei carichi radiali e assiali generati dall'applicazione debbono essere sempre minori o uguali a quelli ammissibili indicati nelle tabelle.

*The values of the radial and axial loads generated by the application must always be lower than or equal to the admissible values reported in the tables.*

Die Werte der Radial- und Axialbelastungen, die durch die Anwendung hervorgehoben werden, dürfen nicht über den in den Tabellen angegebenen zulässigen Werten liegen.

$$F_R \geq Fr_{1-2}$$

Se il carico radiale sull'albero non è applicato a metà della sporgenza dell'albero, il valore del carico ammissibile deve essere valutato utilizzando la formula che si riferisce ad  $F_{r_{1-2}}$ , in cui i valori di a, b e  $F_{r_{1-2}}$  sono riportati nelle tabelle relative ai carichi radiali.

Nel caso di alberi bisporgenti il valore del carico applicabile a ciascuna estremità è uguale ai 2/3 del valore di tabella, purché i carichi applicati siano uguali di intensità e direzione ed agiscano nello stesso senso. Diversamente contattare il servizio tecnico.

*Should the radial load affect the shaft not at the half-way point of its projection but at a different point, the value of the admissible load has to be calculated using the  $F_{r_{1-2}}$  formula: a, b and  $F_{r_{1-2}}$  values are reported in the radial load tables.*

*With regard to double-projecting shafts, the load applicable at each end is 2/3 of the value given in the table, on condition that the applied loads feature same intensity and direction and that they act in the same direction.*

*Otherwise please contact the technical department.*

Falls die Radialbelastungen nicht in dem Mittelpunkt der herausragenden Welle sondern in einem anderen Punkt wirken, soll die zulässige Belastung mit der Formel bezüglich  $F_{r_{1-2}}$  kalkuliert werden: a, b und  $F_{r_{1-2}}$  Werte sind aus der Tabelle der Radialbelastungen zu entnehmen.

Bei doppelseitigen Abtriebswellen ist die Belastung, die an jedem Ende anwendbar ist, 2/3 des in der Tabelle angegebenen Wertes unter der Bedingung, dass die Belastungen die selbe Stärke und Richtung aufweisen und dass sie in der selben Richtung wirken. Andernfalls muß mit dem technischen Büro Rücksprache gehalten werden.

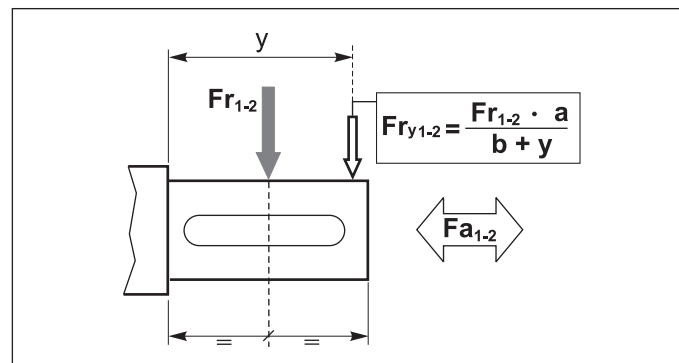

I carichi radiali indicati nelle tabelle si intendono applicati a metà della sporgenza dell'albero e sono riferiti ai riduttori operanti con fattore di servizio 1.

*The radial loads indicated in the chart are considered to be applied at the half-way point of the shaft projection, and refer to gear units operating with service factor 1.*

Die Radialbelastungen, die in den Tabellen angegeben werden, gelten für Ansatzpunkte in der Mitte des herausragenden Wellenteils und für Getriebe mit Betriebsfaktor 1.

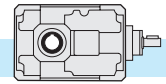

		T 56B		T 63B		T 75B				T 56C		T 63C		T 75C	
ALBERO ENTRATA / INPUT SHAFT / ANTRIEBSWELLE ( $n_1 = 1400 \text{ min}^{-1}$ )															
in	a = *	b = *	a = *	b = *	a = *	b = *	in	a = *	b = *	a = *	b = *	a = *	b = *	a = *	b = *
	Fr <sub>1</sub>	Fa <sub>1</sub>	Fr <sub>1</sub>	Fa <sub>1</sub>	Fr <sub>1</sub>	Fa <sub>1</sub>		Fr <sub>1</sub>	Fa <sub>1</sub>	Fr <sub>1</sub>	Fa <sub>1</sub>	Fr <sub>1</sub>	Fa <sub>1</sub>	Fr <sub>1</sub>	Fa <sub>1</sub>
Tutti A// Alle	*	*	*	*	*	*	Tutti A// Alle	*	*	*	*	*	*	*	*

\* Consultare il ns. Servizio Tecnico.

\* Contact Tramec Technical dept..

\* Fragen sie Tramec technisches Büro.

		T 56B		T 63B		T 75B				T 56C		T 63C		T 75C	
ALBERO USCITA / OUTPUT SHAFT / ABTRIEBSWELLE ( $n_1 = 1400 \text{ min}^{-1}$ )															
	a = 106	b = 81	a = 121	b = 93.5	a = 106	b = 81	in	a = 106	b = 81	a = 121	b = 93.5	a = 121	b = 93.5		
	Fr <sub>2</sub>	Fa <sub>2</sub>	Fr <sub>2</sub>	Fa <sub>2</sub>	Fr <sub>2</sub>	Fa <sub>2</sub>		Fr <sub>2</sub>	Fa <sub>2</sub>	Fr <sub>2</sub>	Fa <sub>2</sub>	Fr <sub>2</sub>	Fa <sub>2</sub>		
8	1300	260	1500	300	2500	500	40	2300	460	2500	500	—	—		
10	1300	260	1500	300	2500	500	50	2300	460	2500	500	3500	700		
12.5	1300	260	1500	300	2500	500	63	2300	460	2500	500	3500	700		
16	1800	360	2000	400	2500	500	80	2800	560	3000	600	3500	700		
20	1800	360	2000	400	3000	600	100	2800	560	3000	600	4000	800		
25	1800	360	2000	400	3000	600	125	2800	560	3000	600	4000	800		
31.5	1800	360	2000	400	3000	600	160	2800	560	3000	600	4000	800		
40	2300	460	2500	500	3500	700	200	3000	600	3500	700	4500	900		
50	2300	460	2500	500	3500	700	250	3000	600	3500	700	4500	900		
63	—	—	2500	500	—	—	315	—	—	3500	700	—	—		

		T 71B		T 90B		T 112B		T 140B		T 180B		T200B		T 225B	
ALBERO ENTRATA / INPUT SHAFT / ANTRIEBSWELLE ( $n_1 = 1400 \text{ min}^{-1}$ )															
in	a = 66.75	b = 51.75	a = 77	b = 57	a = 90	b = 70	a = 113	b = 83	a = 141.5	b = 101.5	a = 138.5	b = 98.5	a = 201	b = 146	
	Fr <sub>1</sub>	Fa <sub>1</sub>	Fr <sub>1</sub>	Fa <sub>1</sub>	Fr <sub>1</sub>	Fa <sub>1</sub>	Fr <sub>1</sub>	Fa <sub>1</sub>	Fr <sub>1</sub>	Fa <sub>1</sub>	Fr <sub>1</sub>	Fa <sub>1</sub>	Fr <sub>1</sub>	Fa <sub>1</sub>	
8-40	400	80	630	125	1000	200	1600	320	2500	500	2500	500	3150	630	
50÷ 80									2000	400	2000	400			
ALBERO USCITA / OUTPUT SHAFT / ABTRIEBSWELLE ( $n_1 = 1400 \text{ min}^{-1}$ )															
in	a = 114.5	b = 84.5	a = 131	b = 95	a = 161.5	b = 113.5	a = 192	b = 132	a = 236.5	b = 162	a = 276	b = 191	a = 325	b = 220	
	Fr <sub>2</sub>	Fa <sub>2</sub>	Fr <sub>2</sub>	Fa <sub>2</sub>	Fr <sub>2</sub>	Fa <sub>2</sub>	Fr <sub>2</sub>	Fa <sub>2</sub>	Fr <sub>2</sub>	Fa <sub>2</sub>	Fr <sub>2</sub>	Fa <sub>2</sub>	Fr <sub>2</sub>	Fa <sub>2</sub>	
≤ 8	—	—	4300	860	7000	1400	11000	2200	—	—	25000	5000	36000	7200	
10	3000	600	4750	950	7500	1500	11800	2360	19000	3800	26800	5360	38000	7600	
12.5	3150	630	5000	1000	8000	1600	12500	2500	20000	4000	28800	5760	40000	8000	
16	3350	670	5300	1060	8500	1700	13200	2640	21200	4240	30400	6080	42400	8480	
18*	—	—	—	—	—	—	13600	2720	21800	4360	—	—	—	—	
20	3550	710	5600	1120	9000	1800	14000	2800	22400	4480	32200	6440	44800	8960	
25	3750	750	6000	1200	9500	1900	15000	3000	23600	4720	34000	6800	47200	9440	
31.5	4000	800	6300	1260	10000	2000	16000	3200	25000	5000	35800	7160	50000	10000	
35*	—	—	—	—	—	—	16500	3300	25700	5140	—	—	—	—	
40	4250	850	6700	1340	10600	2120	17000	3400	26500	5300	37600	7520	53000	10600	
50 ÷ 80	4500	900	7100	1420	11200	2240	18000	3600	28000	5600	38000	7600	—	—	

\* Rapporti speciali / Special ratios / Sonderverhältnisse

		T 80C		T 100C		T 125C		T 160C		T180C		T 200C	
ALBERO ENTRATA / INPUT SHAFT / ANTRIEBSWELLE ( $n_1 = 1400 \text{ min}^{-1}$ )													
in	a = 66.75	b = 51.75	a = 77	b = 57	a = 90	b = 70	a = 113	b = 83	a = 113	b = 83	a = 141.5	b = 101.5	
	Fr <sub>1</sub>	Fa <sub>1</sub>	Fr <sub>1</sub>	Fa <sub>1</sub>	Fr <sub>1</sub>	Fa <sub>1</sub>	Fr <sub>1</sub>	Fa <sub>1</sub>	Fr <sub>1</sub>	Fa <sub>1</sub>	Fr <sub>1</sub>	Fa <sub>1</sub>	
Tutti A// Alle	400	80	630	125	1000	200	1600	320	2000	400	2500	500	
ALBERO USCITA / OUTPUT SHAFT / ABTRIEBSWELLE ( $n_1 = 1400 \text{ min}^{-1}$ )													
in	a = 131	b = 95	a = 161.5	b = 113.5	a = 192	b = 132	a = 236.5	b = 162	a = 276	b = 191	a = 325	b = 220	
	Fr <sub>2</sub>	Fa <sub>2</sub>	Fr <sub>2</sub>	Fa <sub>2</sub>	Fr <sub>2</sub>	Fa <sub>2</sub>	Fr <sub>2</sub>	Fa <sub>2</sub>	Fr <sub>2</sub>	Fa <sub>2</sub>	Fr <sub>2</sub>	Fa <sub>2</sub>	
Tutti A// Alle	8000	1600	12500	2500	20000	4000	32000	6400	43000	8600	53000	10600	

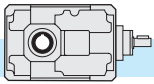

## TA/TF 56B - TA/TF 63B - TA/TF 75B

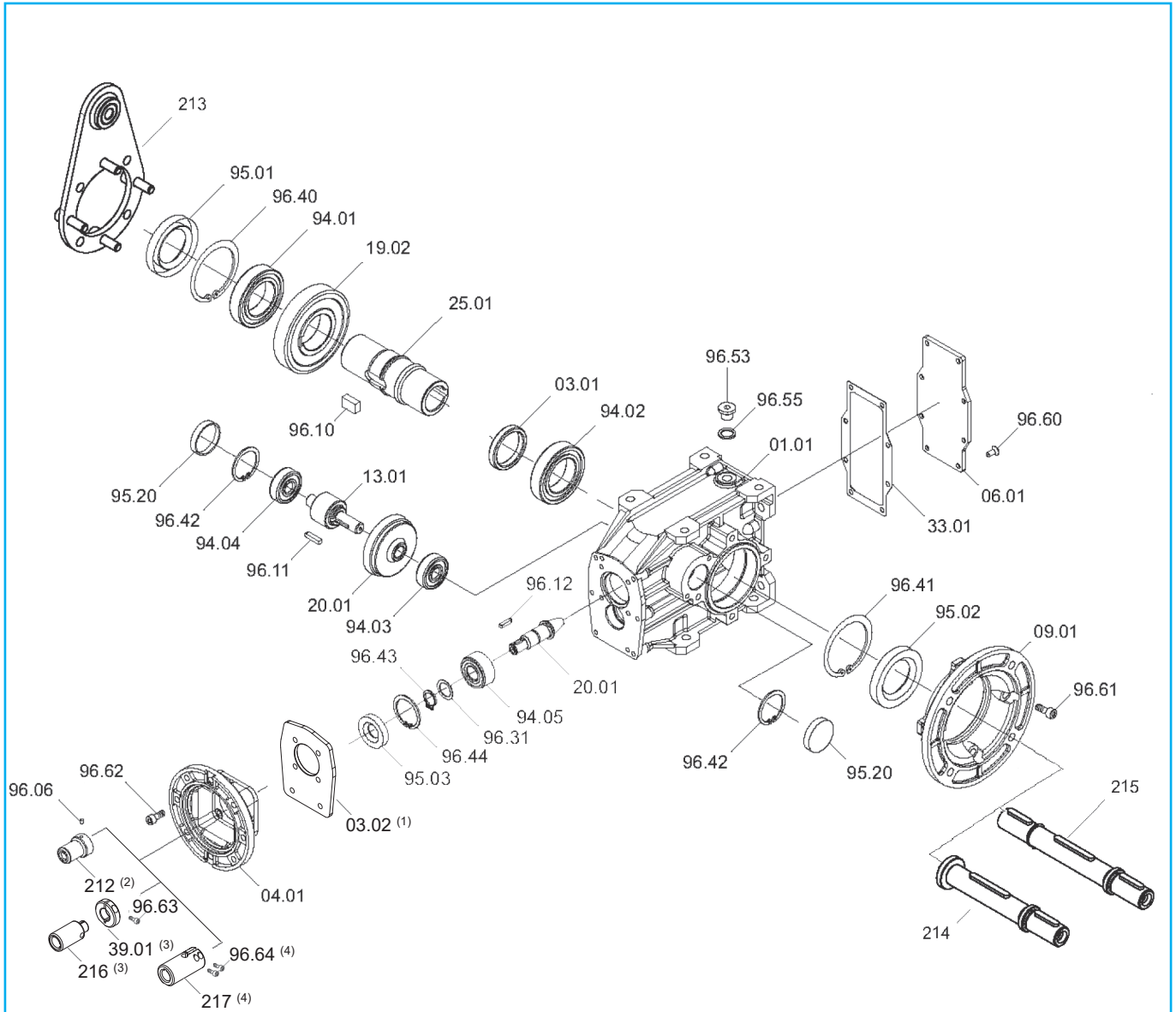

T	Cuscinetti/ Bearings / Lager					Anelli di tenuta / Oilseals / Öldichtungen			Cappellotto / Closed oil seal / Geschlossene Öldichtung
	94.01	94.02	94.03	94.04	94.05	95.01	95.02	95.03	95.20
<b>56B</b>	<b>6007</b> 35/62/14	<b>6007</b> 35/62/14	<b>6201</b> 12/32/10	<b>6201</b> 12/32/10	<b>3201</b> 12/32/15.9	35/62/7	35/62/7	<b>12/32/7</b>	ø 32x7
<b>63B</b>	<b>6008</b> 40/68/15	<b>6008</b> 40/68/15	<b>6301</b> 12/37/12	<b>6301</b> 12/37/12	<b>3202</b> 15/35/15.9	40/68/10	40/68/10	<b>15/35/7</b>	ø 37x7
<b>75B</b>	<b>6010</b> 50/80/16	<b>6010</b> 50/80/16	<b>6203</b> 17/40/12	<b>6203</b> 17/40/12	<b>3202</b> 15/35/15.9	50/80/8	50/80/8	<b>15/35/7</b>	ø 47x7

(1) Solo per TF75B PAM 71, 80, 90 / Only for TF75B PAM 71, 80, 90 / Nur für T75B PAM 71, 80, 90.

(2) Solo per TF56B e TF63B PAM 56, 63 / Only for TF56B and TF63B PAM 56, 63 / Nur für TF56B und TF63B PAM 56, 63.

(3) Solo per TF56B e TF63B PAM 71, 80, 90 / Only for TF56B and TF63B PAM 71, 80, 90 / Nur für TF56B und TF63B PAM 71, 80, 90.

(4) Solo per TF75B tutti i PAM / Only for TF75B all PAM / Nur für TF75B alle PAM.

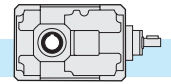

## TA/TF 56C - TA/TF 63C - TA/TF 75 C

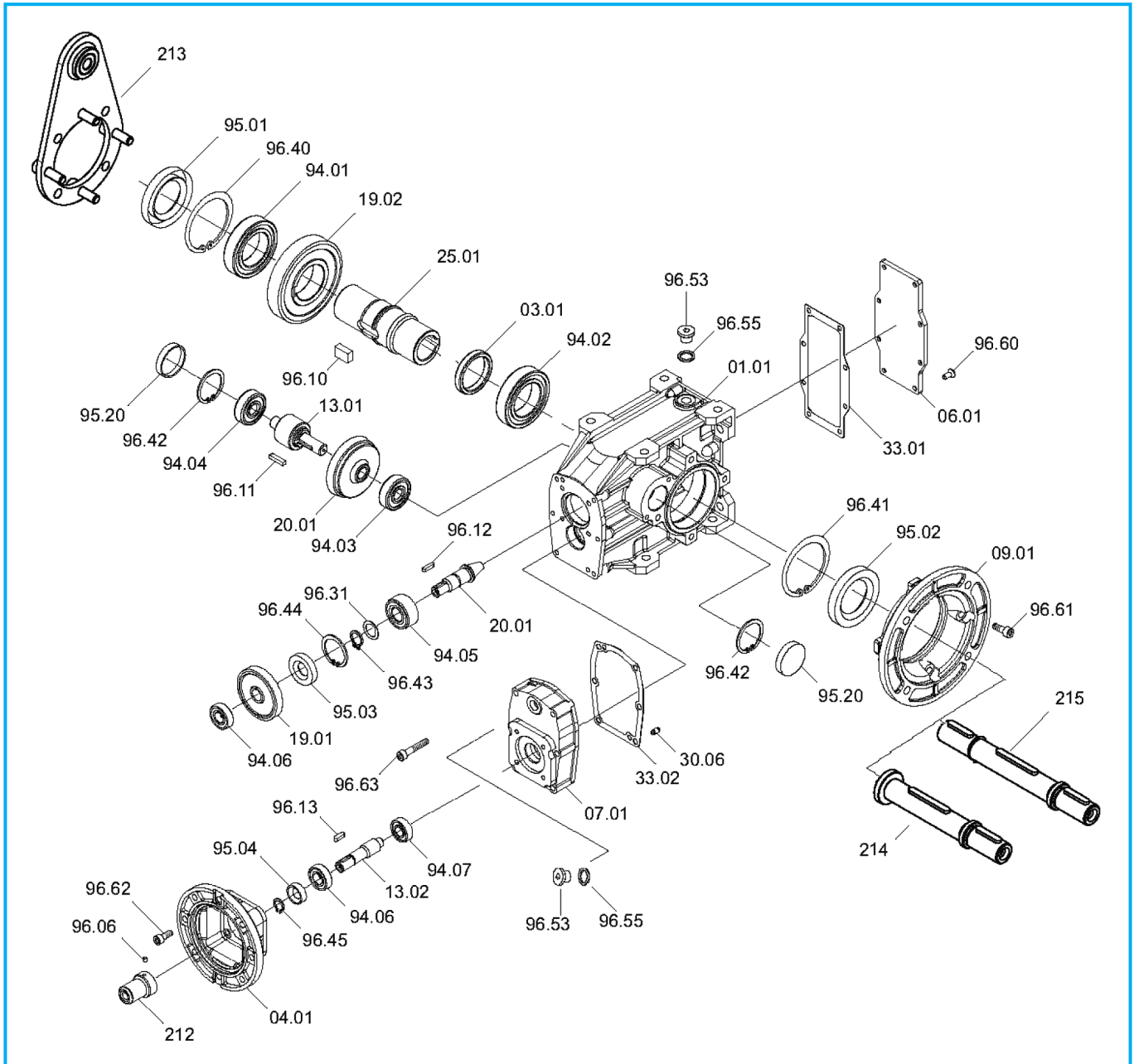

T	Cuscinetti/ Bearings / Lager								Anelli di tenuta / Oilseals / Öldichtungen				Cappellotto / Closed oil seal / Geschlossene Öldichtung
	94.01	94.02	94.03	94.04	94.05	94.06	94.07	94.08	95.01	95.02	95.03	95.04	95.20
<b>56C</b>	6007 35/62/14	6007 35/62/14	6201 12/32/10	6201 12/32/10	3201 12/32/15.9	6001 12/28/8	6000 10/26/8	6001 12/28/8	35/62/7	35/62/7	12/32/7	12/22/7	ø 32x7
<b>63C</b>	6008 40/68/15	6008 40/68/15	6301 12/37/12	6301 12/37/12	3202 15/35/15.9	6001 12/28/8	6000 10/26/8	6001 12/28/8	40/68/10	40/68/10	15/35/7	12/22/7	ø 37x7
<b>75C</b>	6010 50/80/16	6010 50/80/16	6203 17/40/12	6203 17/40/12	3202 15/35/15.9	6002 16/32/9	6000 10/26/8	6001 12/28/8	50/80/8	50/80/8	15/35/7	12/22/7	ø 47x7

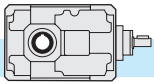

**TA..B - TC..B - TF..B**

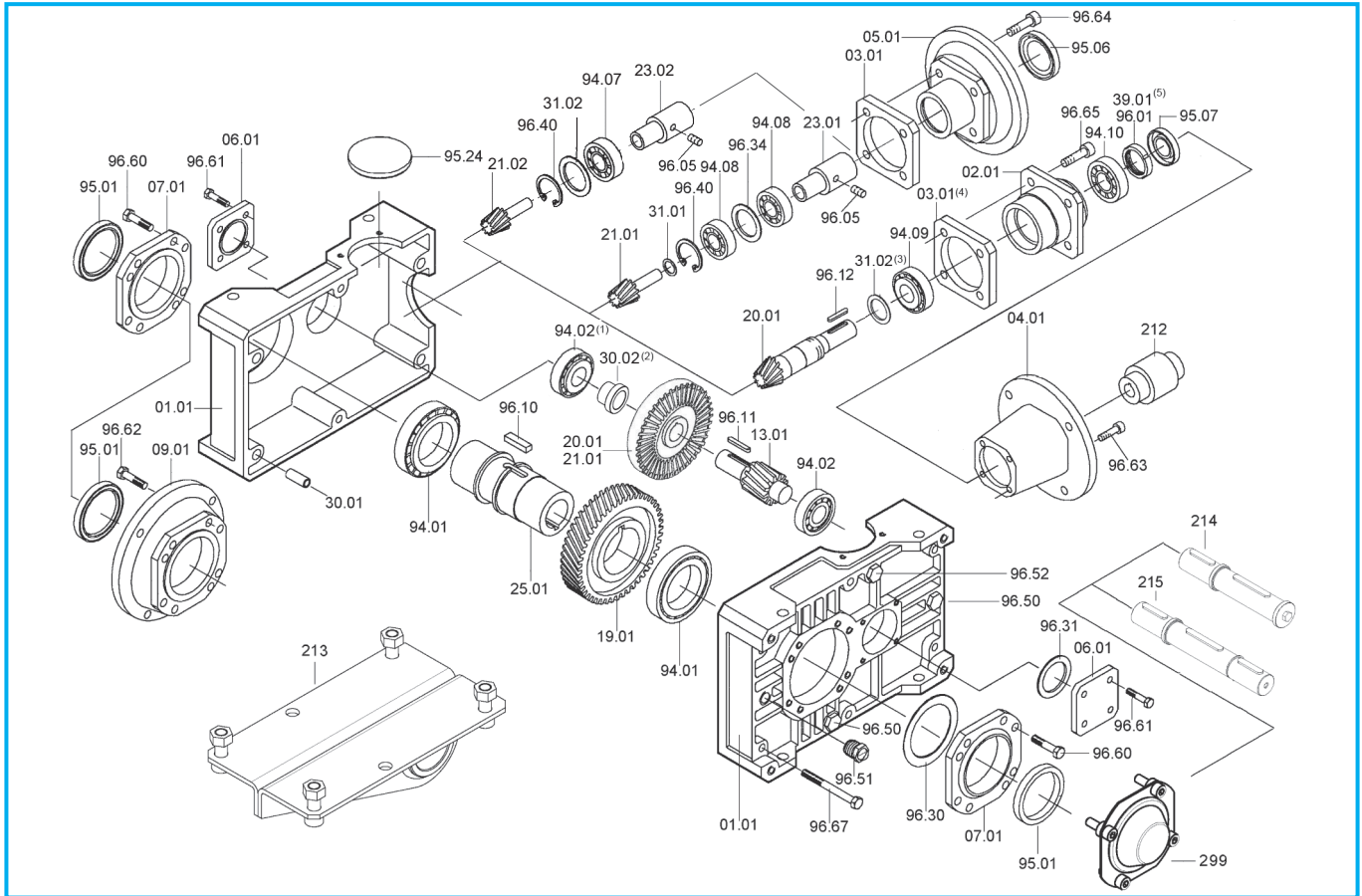

T	Cuscinetti/ Bearings / Lager						Anelli di tenuta / Oilseals / Öldichtungen					
	TA - TC - TF		TC		TA - TF		TA - TC - TF		TC		TA - TF	
	94.01	94.02	94.07	94.08	94.09	94.10	95.01	IEC	95.06	95.07		
<b>71B</b>	32008 40/68/19	30302 15/42/14.25	3203 17/40/17.5 (i= 50, 63, 80)	7203 17/40/12	30203 17/40/13.25	94.09	94.10	40/56/8	63	25/52/7	15/40/10	
									71	30/52/7		
									80	35/52/7		
									90	37/52/8		
<b>90B</b>	32010 50/80/20	30204 20/47/15.25	3205 25/52/20.6 (i= 50, 63, 80)	7205 25/52/15	32005 25/47/15	94.09	94.10	50/65/8	71 - 80	35/62/7	20/47/7	
									90	40/62/7		
									100 - 112	45/62/8		
									80 - 90	40/72/7		
<b>112B</b>	32012 60/95/23	30305 25/62/18.25	3206 30/62/23.8 (i= 50, 63, 80)	7206 30/62/16	32006 30/55/17	94.09	94.10	60/80/10	100 - 112	45/72/8	25/58/10	
									132	55/72/10		
									80 - 90	45/80/10		
									100 - 112	45/80/10		
<b>140B</b>	32015 75/115/25	32206B 30/62/21.25	3207 35/72/27 (i= 50, 63, 80)	7207 35/72/17	32007 35/62/18	94.09	94.10	75/95/10	132	55/80/10	30/62/7	
									160	60/80/8		
									180	65/80/8		
									100 - 112	55/100/13		
<b>180B</b>	32019 95/145/32	31307 35/80/22.75	—	7209 45/85/19	33109 45/80/26	94.09	94.10	95/125/12	132 - 160	60/100/10	40/80/10	
		32208 (1) 40/80/24.75							180	65/100/10		
									200	75/100/10		
									100 - 112	55/100/13		
<b>200B</b>	32024 120/180/38	31309 45/100/27.25	—	7209 45/85/19	33109 45/80/26	94.09	94.10	120/160/15	132 - 160	60/100/10	40/80/10	
										180		65/100/10
										200		75/100/10
										100 - 112		55/100/13
<b>225B</b>	32026 130/200/45	31310 50/110/29.25	—	—	33211 55/100/35	94.09	94.10	130/160/12	—	—	75/100/10	

(1) Presente solo nella versione con antiretro / Only on version with back stop device / Nur für die Version mit Rücklaufsperr

(2) Solo per T200B / Only for T200B / Nur für T200B

(3) Solo per T225B i=16 - 40 (no per i = 8 - 12.5) / Only for T225B i = 16- 40 (not for i = 8 - 12.5) / Nur für T225B i= 16- 40 (Nicht für i = 8 - 12.5)

(4) Non presente nel T225B / Not on T225B / Nicht vorhanden für T225B

(5) Solo per T225B / Only for T225B / Nur für T225B



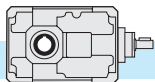

**TA..B - TC..B - TF..B - TA..C - TC..C - TF..C**

**Dispositivo antiritorno - Backstop device - Rücklaufperre**

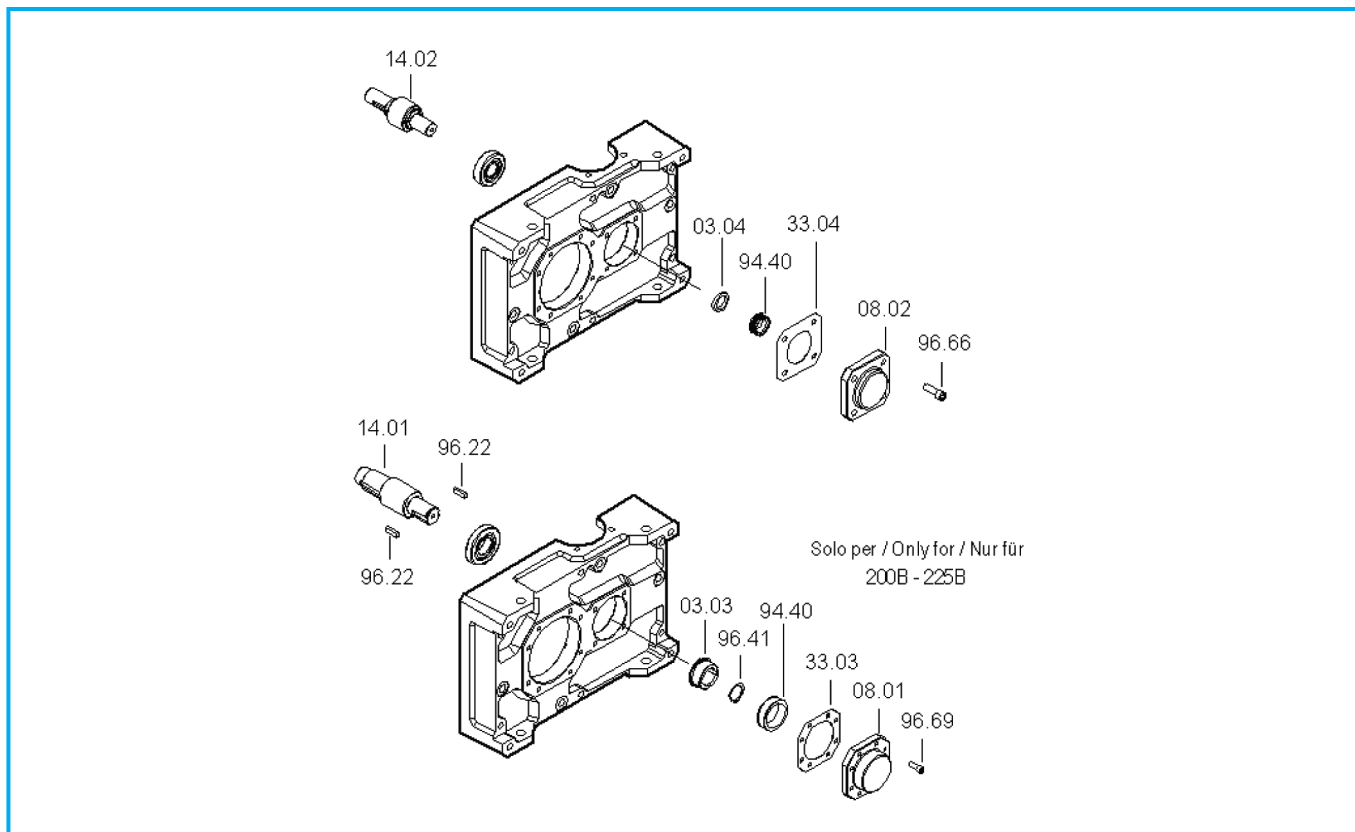

T...B	Ruota libera / Free wheel / Freilauftrad 94.40
71	FE 423 Z
90	FE 428 Z
112	BF 50 Z 16
140	BF 70 Z 21
180	FE 8040 Z 19
200	FE 8054 Z 25
225	FE 8072 Z 25

T...C	Ruota libera / Free wheel / Freilauftrad 94.40
80	FE 423 Z
100	FE 428 Z
125	BF 50 Z 16
160	BF 70 Z 21
180	BF 70 Z 21
200	FE 8040 Z 19

In fase di ordine delle parti di ricambio, specificare sempre n° particolare (vedi disegno esploso), data (1), n° codice (2) e n° variante (3). (Vedi targhetta).

CODICE: distinta base  
CODE: base list  
ART.-Nr.: Basisstückliste

TIPO: descrizione  
TYPE: description  
TYP: Bezeichnung

When ordering please specify the spare part number (see exploded view) as well as the date (1), the article number (2) and the variant number (3) (see plate)

Bei der Bestellung von Ersatzteilen sind Ersatzteilnummer (s. Explosionszeichnung), Datum (1), Artikelnummer (2) und Variantennummer (3) anzugeben. (s. Schild)

VARIANTE: codice alfanumerico  
MODEL: alphanumeric code  
VARIANTE: alphanumerische Nummer

RAP: rapporto di riduzione  
RATIO: reduction ratio  
ÜBERS: Untersetzungsverhältnis

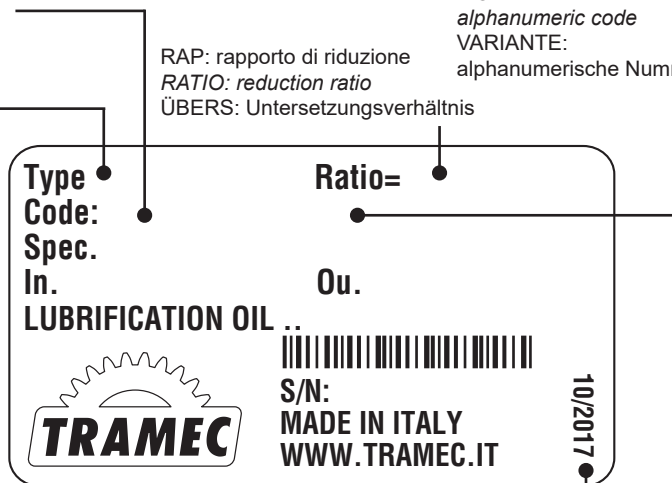

DATA: mese/anno  
DATE: month/year  
DATUM: Monat/Jahr

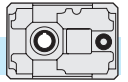

### 3.0 RIDUTTORI AD ASSI PARALLELI

### PARALLEL SHAFT GEARBOX

### PARALLELENGETRIEBE

3.1	Caratteristiche	<i>Characteristics</i>	Merkmale	46
3.2	Designazione	<i>Designation</i>	Bezeichnung	47
3.3	Velocità in entrata	<i>Input speed</i>	Antriebsdrehzahl	47
3.4	Rendimento	<i>Efficiency</i>	Wirkungsgrad	47
3.5	Potenza termica	<i>Thermal power</i>	Thermische Leistung	48
3.6	Dati tecnici	<i>Technical data</i>	Technische Daten	48
3.7	Momenti d'inerzia	<i>Moments of inertia</i>	Trägheitsmoment	50
3.8	Dimensioni	<i>Dimensions</i>	Abmessungen	54
3.9	Seconda entrata	<i>Second input</i>	Zweiter Antrieb	56
3.10	Accessori	<i>Accessories</i>	Zubehör	56
3.11	Giochi angolari	<i>Angular backlash</i>	Winkelspiel	59
3.12	Lubrificazione	<i>Lubrication</i>	Schmierung	60
3.13	Carichi radiali e assiali	<i>Radial and axial loads</i>	Radial- und Axialbelastungen	61
3.14	Lista parti di ricambio	<i>Spare parts list</i>	Ersatzteilliste	63

ZF..

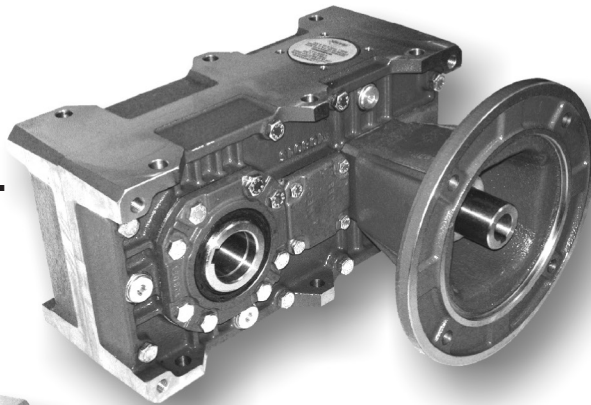

ZA..

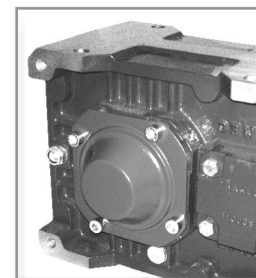
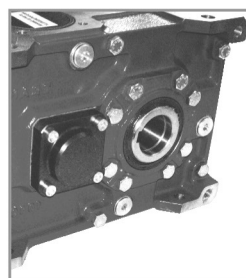
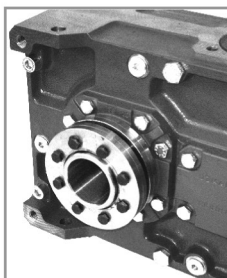
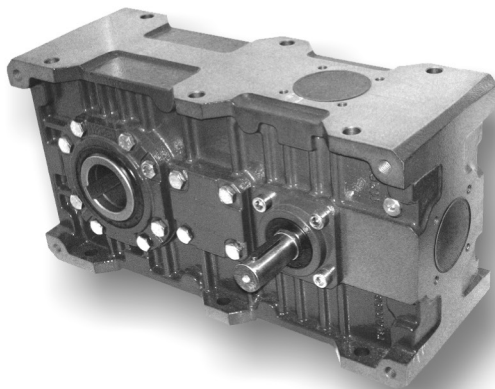



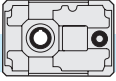

### 3.1 Caratteristiche

- Costruiti in 6 grandezze a una riduzione, 6 a 2 riduzioni e 6 grandezze a 3 riduzioni.
- Sono previsti due tipi di entrata: con albero entrata sporgente, con predisposizione attacco motore (campana e giunto).
- Il corpo riduttore in ghisa meccanica EN GJL 200 UNI EN 1561(71-180), abbondantemente nervato all'interno e all'esterno per garantire la rigidità, è lavorato su tutti i piani per consentire un facile posizionamento; inoltre un'unica camera di lubrificazione garantisce una maggiore dissipazione termica e una migliore lubrificazione di tutti gli organi interni.
- Gli ingranaggi cilindrici, a dentatura elicoidale, sono costruiti in acciaio 16NiCr4, 18NiCrMo5 o 20MnCr5 UNI EN 10084 cementati e temprati, tutti rettificati entro la classe di qualità 6 della DIN 3962.
- L'utilizzo dei cuscinetti a rulli conici di qualità su tutti gli assi consente al riduttore di ottenere delle durate molto elevate e di sopportare dei carichi radiali e assiali esterni di notevole entità.
- L'albero lento cavo di serie in acciaio (disponibile a richiesta con calettatore), la possibilità di montare una flangia uscita sul fianco opposto all'albero entrata e la predisposizione per il montaggio del dispositivo antiritorno esaltano la versatilità di questi riduttori facilitandone l'installazione.
- Il corpo riduttore, le flange, le campane ed i coperchi vengono verniciati esternamente di colore BLU RAL 5010.

### 3.1 Characteristics

- *Built in 6 sizes with single reduction stage, in 6 sizes with two reduction stages and in 6 sizes with three reduction stages.*
- *Two input types are available : with projecting input shaft, with pre-engineered motor coupling (bell and joint).*
- *The gear unit body in engineering cast iron, EN GJL 200 UNI EN 1561 is internally and externally ribbed to guarantee rigidity, it is machined on all surfaces for easy positioning. The single lubrication chamber guarantees improved heat dissipation and better lubrication of all the internal components.*
- *The helical spur gears are built in 16NiCr4, 18NiCrMo5 or 20MnCr5 UNI EN 10084 quench-hardened and case-hardened steel, all ground according to quality 6 DIN 3962.*
- *The use of high-quality tapered roller bearings on all shafts ensures long life, and enables very high external radial and axial loads.*
- *The standard hollow output shaft made of steel (shrink disc available on request), the option of mounting an output flange on the side opposite to the input shaft the possibility of mounting a backstop device make these gear units extremely versatile and easy to install.*
- *Gearbox housing, flanges, bells and covers are externally painted with BLUE RAL 5010.*

### 3.1 Merkmale

- Erhältlich in 6 Größen mit einer Unterstufungsstufe, in 6 Größen mit 2 Unterstufungsstufen und 6 Größen mit drei Unterstufungsstufen.
- Zwei Antriebsarten (Getriebeeingang) sind lieferbar: Eingangswelle, Motoranbau mit Glocke und Kupplung, Motor Direktanbau.
- Das Getriebegehäuse ist aus Maschinenguss EN GJL 200 UN EN 1561 innen als auch außen mit Rippen versehen, die die Steifheit gewährleisten; die Bearbeitung aller Flächen ermöglicht eine leichte Positionierung. Eine einzige Schmierkammer gewährleistet eine höhere Wärmedissipation und eine bessere Schmierung aller inneren Elemente.
- Die Schrägstriräder bestehen aus einsatz- und abschreckgehärtetem 16NiCr4, 18NiCrMo5-oder 20MnCr5-Stahl UNI EN 10084, geschliffen innerhalb Qualitätsklasse 6 der Spez. DIN 3962.
- An allen Achsen wurden Qualitäts-Kegelrollenlager verwendet, diese gewährleisten eine hohe Lebensdauer und das Aushalten sehr hoher äußerer Radial und Axialbelastungen.
- Die serienmäßige Abtriebshohlwelle aus Stahl (auf Wunsch mit Schrumpfscheibe erhältlich), die Möglichkeit der Montage eines Abtriebsflansches auf der Seite gegenüber der Antriebswelle und die Auslegung für die Montage der Rücklauf Sperre heben die Vielseitigkeit dieser Unterstufungsgetriebe hervor und erleichtern ihren Einbau.
- Getriebegehäuse, Flansche, Glocken und Deckel werden in BLAU RAL 5010 lackiert.

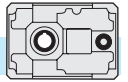

### 3.2 Designazione

### 3.2 Designation

### 3.2 Bezeichnung

Macchina Machine Maschine	Tipo entrata Input type Antriebsart	Grandezza Size Größe	Rotismo Gearing Räderwerk	Rapporto rid. Ratio Untersetzungsverhältnis	Predisposiz. Motor coupling Motoranschluss	Albero uscita cavo Hollow output shaft Abtriebshohlwelle	Entrata supplementare Additional input Zusatzantrieb	Esecuzione Execution Ausführung	Posizione di montaggio Mounting position Baulage	Flangia uscita Output flange Abtriebsflansch	Antiritorsmo Back-stop device Rücklaufsperr	Calettatore Shrink disk Schrumpfscheibe	
Z	A	112	B	10	P.A.M.	-	S.e.A.	O	B3	FLD	CW	C.S.	
Riduttore ad assi paralleli Parallel shaft gear unit Parallelgetriebe	A	71 90 112 140 180 225	A	$i_n =$ 5 ÷ 280	71 + 200	(1)	A	O	B3 V1 V3 VA VB	FLD	AW	C.S.	
	F	80 100 125 160 180 200	B				F				FLD	CW	C.D.
		80 100 125 160 180 200	C										

(1) Indicare il diametro dell'albero cavo **solo** se non è standard.

Es.: Z A 112 B 10 90 O B3 40

(1) Diameter of the hollow output shaft to be specified only if it is not standard.

Ex.: Z A 112 B 10 90 O B3 40

(1) Benennen Sie bitte den Durchmesser der Abtriebshohlwelle, insofern dieser nicht dem Standarddurchmesser entspricht

Beispiel: Z A 112 B 10 90 O B3 40

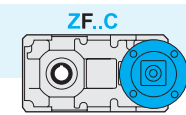
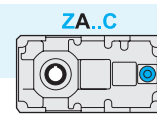
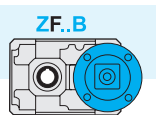
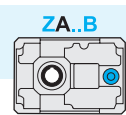
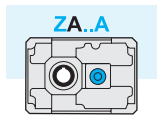

### 3.3 Velocità in entrata

### 3.3 Input speed

### 3.3 Antriebsdrehzahl

Tutte le prestazioni dei riduttori sono calcolate in base ad una velocità in entrata di 1400 min<sup>-1</sup>.

Tutti i riduttori ammettono velocità fino a 3000 min<sup>-1</sup> anche se è consigliabile, dove l'applicazione lo permette, utilizzare valori inferiori a 1400 min<sup>-1</sup>.

Nella tabella sottostante riportiamo i coefficienti correttivi della potenza in entrata P alle varie velocità riferita ad Fs = 1

All calculations of gear unit performance are based on an input speed of 1400 min<sup>-1</sup>. All gear units permit speed up to 3000 min<sup>-1</sup>, nevertheless it is advisable to keep below 1400 min<sup>-1</sup>, depending on application.

The table below reports input power P corrective coefficients at the various speeds, with Fs = 1.

Bei der Berechnung der Getriebeleistungen wurde eine Antriebsdrehzahl von 1400 min<sup>-1</sup> berücksichtigt.

Bei allen Getrieben sind Antriebsdrehzahlen bis 3000 min<sup>-1</sup> möglich; es ist jedoch ratsam, die Drehzahlen unter 1400 min<sup>-1</sup> zu halten, wenn die Anwendung es ermöglicht.

In der folgenden Tabelle finden Sie die Korrekturkoeffizienten für die Antriebsleistung P bei den verschiedenen Drehzahlen, bezogen auf Fs = 1.

Tab. 1

n <sub>1</sub> [min <sup>-1</sup> ]	3000	2800	2200	1800	1400	900	700	500
Pc (kW)	P x 1.9	P x 1.8	P x 1.48	P x 1.24	P x 1	P x 0.7	P x 0.56	P x 0.42

### 3.4 Rendimento

### 3.4 Efficiency

### 3.4 Wirkungsgrad

Il valore del rendimento dei riduttori può essere stimato con sufficiente approssimazione in base al numero di riduzioni, trascurando le variazioni non significative attribuibili alle varie grandezze e rapporti.

The efficiency value of the gear units can be estimated sufficiently well on the basis of the number of reduction stages, ignoring non-significant variations which can be attributed to the various sizes and ratios.

Der Wirkungsgrad des Getriebes kann mit ausreichender Annäherung aufgrund der Anzahl der Untersetzungsstufen ermittelt werden; dabei können die unwesentlichen Veränderungen, die auf die verschiedenen Größen und Untersetzungsverhältnisse zurückzuführen sind, außer acht gelassen werden.

η	Z...A	Z...B	Z...C
	0.97	0.95	0.93

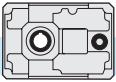

### 3.5 Potenza termica

### 3.5 Thermal power

### 3.5 Thermische Leistung

I valori delle potenze termiche,  $P_{10}$  (kW), sono riportati nella tabella seguente, in funzione di grandezza, rapporto e velocità entrata del riduttore. I valori sono calcolati considerando l'utilizzo di olio sintetico ISO 320. Vedere paragrafo 1.4 per la scelta dei fattori correttivi.

The following table shows the values of thermal power  $P_{10}$  (kW) for each gearbox size on the basis of ratio and input speed. The values have been calculated considering the utilization of synthetic oil ISO 320. See chapter 1.4 for the corrective coefficients.

Die folgende Tabelle enthält die Werte  $P_{10}$  der thermischen Leistung (kW) je nach Getriebegröße und abhängig von Untersetzung und von Drehzahlen am Getriebeantrieb. Die angegebenen Werte beziehen sich auf Schmiering mit synthetischem Öl ISO 320. Im Abschnitt 1.4 finden Sie die Korrekturkoeffizienten.

Tab. 2

Potenza Termica / Thermal power / Thermische Leistung $P_{10}$ [kW]												
	Z71A		Z90A		Z112A		Z140A		Z180A		Z225A	
$i_n$	1400	2800	1400	2800	1400	2800	1400	2800	1400	2800	1400	2800
5	5.5		10		16.5		28.5		49.6	47	93	67
6.3	5		8.6		14.5	15.4	24.8	25.8	-		-	
8	4		7		12	13	20.6	22	-		-	
	Z80B		Z100B		Z125B		Z160B		Z180B		Z200B	
$i_n$	1400	2800	1400	2800	1400	2800	1400	2800	1400	2800	1400	2800
8	-		-		-		-		55.7	53.4	75	65.2
10	7		12		20	21	37	37.6	49	48.3	69.4	61.8
12.5	6.5		10.8		18	19	32.7	33.4	43.6	43.4	61	55.3
16	5.8		9.8		16	17	29	30	36.6	40.2	51	54.7
18*	-		-		15	16.2	27.3	29.3	-	-	-	-
20	5		8.7		14	15.5	25.6	28.6	33.2	36.7	48	51.7
25	5		7.8		12.8	14	23.4	26	30.5	33.5	43	46.8
31.5	4.6		7.4		12	13	21.6	23.7	27	29.5	39.4	42.4
35*	-		-		11.6	12.5	20.8	22.7	-	-	-	-
40	4.2		7		11.2	12	20	21.6	25.2	27	-	-
45*	-		-		10.8	11.5	19.2	20.6	-	-	-	-
50	4		6.3		10.3	11	18.3	19.5	-	-	-	-
56*	-		-		9.9	10.6	17.5	18.8	-	-	-	-
63	3.5		5.7		9.4	10.2	16.6	18	-	-	-	-
	Z80C		Z100C		Z125C		Z160C		Z180C		Z200C	
$i_n$	1400	2800	1400	2800	1400	2800	1400	2800	1400	2800	1400	2800
40	-		-		-		-		-		34.2	37.8
50	3.6		6		10	11	17.8	19.8	22.3	25.3	32.7	36
63	3.3		5.6		9.2	10.2	16.3	18.3	20.4	23.3	30.3	33
80	3.2		5.3		8.8	9.7	15.3	17	19.2	21.8	28.2	30.7
90*	-		-		8.4	9.2	14.7	16.3	-	-	-	-
100	2.8		4.8		8	8.8	14	15.5	17.6	19.7	25.5	28.6
125	2.6		4.5		7.5	8.2	13	14.4	16.2	18.5	24	26.8
160	2.5		4.3		7.2	7.8	12.4	13.6	15.3	17	22.5	25
180*	-		-		6.9	7.5	12	13.1	-	-	-	-
200	2.4		4		6.6	7.2	11.5	12.6	14.4	16	-	-
250	2.4		3.8		6.3	7	11	12	13.4	14.7	-	-
280*	-		-		6	6.8	10.5	11.4	-	-	-	-

\* Rapporti speciali  
Special ratios  
Sonderverhältnisse

### 3.6 Dati tecnici

### 3.6 Technical data

### 3.6 Technische Daten

Z	$n_1 = 1400$			ZA	
	$i_n$	$i_r$	$n_2$ rpm	$T_{2M}$ Nm	P kW
71A	5	5.09	275	270	8.0
	6.3	6.10	230	210	5.2
	8	7.88	177	180	3.5
90A	5	5.09	275	590	17.5
	6.3	6.10	230	480	11.9
	8	7.88	177	360	6.9
112A	5	5.09	275	1200	35.6
	6.3	6.10	230	1150	28.5
	8	7.88	177	780	14.9
140A	5	5.09	275	2350	69.8
	6.3	6.10	230	2150	53.3
	8	7.88	177	2100	40.2
180A	5	5.09	275	4800	142.5
225A	5	4.82	291	8600	270

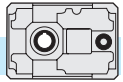

3.6 Dati tecnici

3.6 Technical data

3.6 Technische Daten

Z	n <sub>1</sub> = 1400			ZF				ZA	
	in	ir	n <sub>2</sub> rpm	T <sub>2</sub> Nm	P1 kW	FS'	IEC	T <sub>2M</sub> Nm	P kW
80B	10	10.20	137	119	1.8	4.3	71 80 90	510	7.7
	12.5	12.98	108	151	1.8	3.8		570	6.8
	16	15.56	90	181	1.8	3.5		630	6.3
	20	20.36	69	238	1.8	2.9		700	5.3
	25	24.40	57	285	1.8	2.5		700	4.4
	31.5	31.05	45	362	1.8	1.7		630	3.1
	40	37.21	38	434	1.8	1.3		560	2.3
	50	48.12	29	468	1.5	1.1		520	1.7
80C	50	52.51	27	600	1.8	1.1	63 71 80 90	660	2.0
	63	62.91	22	599	1.5	1.1		680	1.7
	80	80.08	17	559	1.1	1.3		710	1.4
	100	105.52	13	736	1.1	1.0		740	1.1
	125	126.43	11	740	0.9	1.0		740	0.90
	160	160.91	9	561	0.55	1.2		680	0.70
	200	208.11	7	700	0.55	1.0		700	0.55
	250	249.36	6	585	0.37	1.2		720	0.48
100B	10	10.20	137	364	5.5	2.9	71 80 90 100 112	1050	15.9
	12.5	12.98	108	462	5.5	2.5		1150	13.7
	16	15.56	90	554	5.5	2.3		1280	12.7
	20	20.36	69	723	5.5	2		1420	10.8
	25	24.40	57	875	5.5	1.6		1420	9.0
	31.5	31.05	45	1110	5.5	1.2		1290	6.4
	40	37.21	38	965	4	1.3		1220	5.1
	50	48.12	29	936	3	1.1		1060	3.4
100C	50	51.93	27	593	1.8	2.2	71 80 90	1300	4.0
	63	62.22	23	710	1.8	1.9		1350	3.4
	80	79.19	18	904	1.8	1.6		1410	2.8
	100	103.67	14	1184	1.8	1.2		1470	2.2
	125	124.22	11	1418	1.8	1.0		1480	1.9
	160	158.10	9	1103	1.1	1.2		1360	1.4
	200	204.46	7	1400	1.1	1.0		1400	1.1
	250	244.99	6	1399	0.9	1.0		1440	0.9
125B	10	10.20	137	608	9.2	3.5	80 90 100 112 132	2100	31.8
	12.5	12.98	108	774	9.2	3.0		2300	27.3
	16	15.56	90	927	9.2	2.7		2500	24.8
	18*	17.34	81	1025	9.2	2.4		2450	22.0
	20	20.36	69	1214	9.2	2.3		2850	21.6
	25	24.40	57	1455	9.2	2.0		2850	18.0
	31.5	31.05	45	1851	9.2	1.4		2550	12.7
	35*	34.62	40	2076	9.2	1.2		2470	11.0
	40	37.21	38	2218	9.2	1.1		2350	9.8
	45*	41.48	34	1991	7.5	1.2		2400	9.0
	50	48.12	29	2250	7.5	1.0		2250	7.5
	56*	53.64	26	1909	5.5	1.0		1950	5.6
	63	62.23	22	2218	5.5	1.0		2250	5.6
	125C	50	51.93	27	1810	5.5		1.5	71 80 90 100 112
63		62.22	23	2124	5.5	1.3	2760	7.0	
80		79.19	18	2714	5.5	1.0	2880	5.7	
90*		88.28	16	2208	4	1.1	2520	4.5	
100		103.67	14	2631	4	1.1	3000	4.6	
125		124.22	11	2364	3	1.3	3000	3.8	
160		158.10	9	2206	2.2	1.2	2720	2.7	
180*		176.24	8	2430	2.2	1.0	2570	2.3	
200		204.46	7	2800	2.2	1.0	2800	2.2	
250		244.99	6	2798	1.8	1.0	2880	1.9	
280*		273.10	5	2651	1.5	1.0	2600	1.5	

Z	n <sub>1</sub> = 1400			ZF				ZA			
	in	ir	n <sub>2</sub> rpm	T <sub>2</sub> Nm	P1 kW	FS'	IEC	T <sub>2M</sub> Nm	P kW		
160B	10	10.20	137	1454	22	2.8	90 100 112 132 160 180	4000	60.5		
	12.5	12.98	108	1851	22	2.4		4500	53.5		
	16	15.56	90	2218	22	2.2		4900	48.6		
	18*	17.34	81	2451	22	2.1		5200	46.0		
	20	20.36	69	2903	22	1.9		5500	41.7		
	25	24.40	57	3479	22	1.6		5500	34.8		
	31.5	31.05	45	4427	22	1.2		5200	25.8		
	35*	34.62	40	4964	22	1.1		5300	24.0		
	40	37.21	38	4461	18.5	1.1		4700	19.5		
	45*	41.48	34	4911	18.5	1.0		5000	18.5		
	50	48.12	29	3430	11	1.3		4300	13.8		
	56*	53.64	26	3818	11	1.0		3800	11.0		
	63	62.23	22	4300	11	1.0		4300	11.0		
	160C	50	51.93	27	3031	9.2		1.7	80 90 100 112 132	5130	15.6
63		62.22	23	3631	9.2	1.5	5350	13.6			
80		79.19	18	4622	9.2	1.2	5570	11.1			
90*		88.28	16	5080	9.2	1.1	5600	10.0			
100		103.67	14	5800	9.2	1.0	5800	9.2			
125		124.22	11	5800	7.5	1.0	5800	7.5			
160		158.10	9	5470	5.5	1.0	5470	5.5			
180*		176.24	8	4418	4	1.3	5600	5.0			
200		204.46	7	5188	4	1.1	5600	4.3			
250		244.99	6	4663	3	1.2	5760	3.7			
280*		273.10	5	5301	3	1.1	5700	3.3			
180B		8	8.10	173	1155	22	4.4	80 90 100 112 132 160 180		5100	97.2
		10	10.38	135	1480	22	3.8			5650	84.0
		12.5	12.54	112	1787	22	3.5			6200	76.3
	16	16.17	87	2305	22	2.9	6750		64.4		
	20	20.73	68	2955	22	2.5	7300		54.4		
	25	25.03	56	3569	22	2.1	7450		45.9		
	31.5	31.05	45	4427	22	1.7	7550		37.5		
	40	35.07	40	5000	22	1.5	7550		33.2		
180C	50	52.85	26	3085	9.2	2.4	80 90 100 112 132	7530	22.3		
	63	63.33	22	3696	9.2	2.0		7560	18.8		
	80	76.48	18	4464	9.2	1.7		7700	15.9		
	100	94.89	15	5538	9.2	1.4		7650	12.7		
	125	127.43	11	7437	9.2	1.0		7680	9.6		
	160	158.10	9	7265	7.5	1.1		7830	8.1		
	200	197.46	7	6890	5.5	1.1		7870	6.3		
	250	244.99	6	7960	5.5	1.0		7960	5.5		
200B	8	8.33	168	1619	30	4.6	132 160 180 200	7500	139		
	10	10.00	140	1945	30	4.2		8200	127		
	12.5	12.29	114	2389	30	3.8		9000	113		
	16	16.63	84	3233	30	3.0		9800	90.9		
	20	19.97	70	3883	30	2.7		10600	81.9		
	25	24.53	57	4769	30	2.3		11000	69.2		
	31.5	30.04	47	5839	30	1.8		10700	55.0		
	200C	40	42.41	33	5919	22		1.8	100 112 132 160 180	10900	40.5
50		50.93	27	7108	22	1.5	11000	34.1			
63		62.55	22	8730	22	1.3	11350	28.6			
80		76.59	18	10690	22	1.0	11050	22.7			
100		101.68	14	11200	18.5	1.0	11200	18.5			
125		124.87	11	11500	15	1.0	11500	15.0			
160		152.91	9	10671	11	1.0	11200	11.6			

\* Rapporti speciali / Special ratios / Sonderverhältnisse

Verifica termica necessaria / Thermal rating needed / Thermische - Prüfung erforderlich

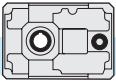

3.7 **Momenti d'inerzia** [Kg.cm<sup>2</sup>]  
(riferiti all'albero veloce in entrata)

3.7 **Moments of inertia** [Kg.cm<sup>2</sup>]  
(referred to input shaft)

3.7 **Trägheitsmoment** [Kg.cm<sup>2</sup>]  
(bez. Antriebswelle)

### ZA..A

<b>71A</b>	$i_n$	<b>ZA</b>
	5	1.11
	6.3	0.89
	8	0.64

<b>112A</b>	$i_n$	<b>ZA</b>
	5	10.00
	6.3	7.34
	8	5.22

<b>180A</b>	$i_n$	<b>ZA</b>
	5	91.58

<b>90A</b>	$i_n$	<b>ZA</b>
	5	3.35
	6.3	2.51
	8	1.79

<b>140A</b>	$i_n$	<b>ZA</b>
	5	28.25
	6.3	21.56
	8	15.32

<b>225A</b>	$i_n$	<b>ZA</b>
	5	369.11

### ZA..B - ZF..B - ZA..C - ZF..C

<b>80B</b>	$i_n$	<b>ZA</b>	<b>ZF</b>				
			IEC B5				
				<b>71</b>	<b>80</b>	<b>90</b>	
			10	2.91	3.86	3.98	5.24
			12.5	2.74	3.69	3.81	5.07
			16	2.62	3.57	3.69	4.96
			20	1.19	2.14	2.27	3.53
			25	0.92	1.87	2.00	3.26
			31.5	0.89	1.84	1.97	3.23
			40	0.87	1.82	1.95	3.21
			50	0.86	1.80	1.93	3.19
63	0.67	1.62	1.74	3.007			

<b>80C</b>	$i_n$	<b>ZA</b>	<b>ZF</b>					
			IEC B5					
				<b>63</b>	<b>71</b>	<b>80</b>	<b>90</b>	
			50	0.71	0.96	1.60	1.74	2.89
			63	0.67	0.93	1.57	1.70	2.85
			80	0.67	0.92	1.56	1.70	2.85
			100	0.30	0.55	1.19	1.32	2.48
			125	0.29	0.54	1.18	1.32	2.47
			160	0.29	0.54	1.18	1.31	2.47
			200	0.28	0.53	1.17	1.31	2.46
			250	0.28	0.53	1.17	1.30	2.46

<b>100B</b>	$i_n$	<b>ZA</b>	<b>ZF</b>					
			IEC B5					
				<b>71</b>	<b>80</b>	<b>90</b>	<b>110-112</b>	
			10	9.50	11.51	11.83	11.76	11.79
			12.5	8.65	10.66	10.98	10.91	10.94
			16	8.25	10.26	10.58	10.51	10.54
			20	2.98	4.99	5.32	5.25	5.27
			25	2.97	4.98	5.31	5.24	5.27
			31.5	2.83	4.84	5.16	5.09	5.12
			40	2.76	4.77	5.09	5.02	5.05
			50	2.71	4.72	5.04	4.97	5.00
63	1.88	3.89	4.22	4.15	4.18			

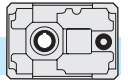





3.7 **Momenti d'inerzia** [Kg.cm<sup>2</sup>]  
(riferiti all'albero veloce in entrata)



3.7 **Moments of inertia** [Kg.cm<sup>2</sup>]  
(referred to input shaft)

3.7 **Trägheitsmoment** [Kg.cm<sup>2</sup>]  
(bez. Antriebswelle)

### ZA..B - ZF..B - ZA..C - ZF..C

100C	$i_n$	ZA 	ZF 		
			IEC B5		
			71	80	90
50	2.93	3.78	3.92	5.09	
63	2.80	3.66	3.80	4.97	
80	2.78	3.64	3.77	4.95	
100	1.22	2.07	2.21	3.38	
125	1.19	2.04	2.18	3.35	
160	1.18	2.04	2.17	3.35	
200	1.15	2.01	2.14	3.32	
250	1.15	2.00	2.14	3.32	

125B	$i_n$	ZA 	ZF 			
			IEC B5			
			80	90	110-112	132
10	27.97	32.64	32.54	32.72	47.58	
12.5	25.19	29.86	29.76	29.94	44.80	
16	24.15	28.83	28.73	28.91	43.77	
18*	23.49	28.16	28.07	28.24	43.10	
20	11.10	15.77	15.67	15.85	30.71	
25	8.67	13.35	13.25	13.43	28.29	
31.5	8.18	12.86	12.76	12.94	27.80	
35*	9.97	14.65	14.55	14.73	29.59	
40	8.00	12.68	12.58	12.76	27.62	
45*	7.89	12.56	12.47	12.64	27.50	
50	7.86	12.53	12.44	12.61	27.47	
56*	5.47	10.14	10.05	10.22	25.08	
63	5.45	10.13	10.03	10.21	25.07	

125C	$i_n$	ZA 	ZF 			
			IEC B5			
			71	80	90	110-112
50	9.06	11.07	11.39	11.32	13.63	
63	8.69	10.70	11.03	10.96	13.27	
80	8.62	10.63	10.95	10.88	13.20	
90*	8.88	10.89	11.22	11.15	13.46	
100	3.92	5.93	6.26	6.18	8.50	
125	3.83	5.84	6.16	6.09	8.41	
160	3.81	5.82	6.15	6.07	8.39	
180*	3.88	5.89	6.21	6.14	8.46	
200	3.72	5.74	6.06	5.99	8.30	
250	3.72	5.73	6.05	5.98	8.30	
280*	3.72	5.73	6.05	5.98	8.30	

\* Rapporti speciali / Special ratios / Sonderverhältnisse

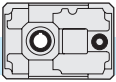

3.7 **Momenti d'inerzia** [Kg.cm<sup>2</sup>]  
(riferiti all'albero veloce in entrata)

3.7 **Moments of inertia** [Kg.cm<sup>2</sup>]  
(referred to input shaft)

3.7 **Trägheitsmoment** [Kg.cm<sup>2</sup>]  
(bez. Antriebswelle)

### ZA..B - ZF..B - ZA..C - ZF..C

	$i_n$	ZA	ZF				
			IEC B5				
			90	110-112	132	160	180
<b>160B</b>	10	86.86	105.43	106.47	107.84	110.02	159.14
	12.5	77.37	95.94	96.98	98.35	100.53	149.65
	16	74.72	93.29	94.33	95.70	97.88	147.00
	18*	73.26	91.83	92.87	94.24	96.42	145.54
	20	33.94	52.52	53.56	54.92	57.10	106.22
	25	26.65	45.23	46.27	47.63	49.81	98.93
	31.5	24.99	43.57	44.61	45.97	48.16	97.27
	35*	30.53	49.10	50.14	51.51	53.69	102.81
	40	24.53	43.11	44.15	45.51	47.69	96.81
	45*	24.27	42.85	43.89	45.26	47.44	96.55
	50	24.00	42.58	43.62	44.98	47.16	96.28
	56*	16.73	35.30	36.34	37.71	39.89	89.01
	63	16.56	35.14	36.18	37.54	39.72	88.84

	$i_n$	ZA	ZF			
			IEC B5			
			80	90	110-112	132
<b>160C</b>	50	27.22	31.55	31.80	31.97	46.83
	63	26.09	30.43	30.67	30.85	45.71
	80	25.84	30.17	30.41	30.59	45.45
	90*	26.69	31.03	31.27	31.45	46.31
	100	11.47	15.80	16.05	16.22	31.08
	125	11.19	15.52	15.76	15.94	30.80
	160	11.12	15.46	15.70	15.88	30.74
	180*	11.34	15.67	15.92	16.09	30.95
	200	10.85	15.19	15.43	15.61	30.47
	250	10.84	15.18	15.42	15.59	30.45
	280*	10.83	15.17	15.41	15.59	30.45

	$i_n$	ZA	ZF				
			IEC B5				
			90	110-112	132	160	180
<b>180B</b>	8	122.78	141.36	142.40	143.76	145.94	195.06
	10	108.97	127.55	128.59	129.95	132.13	181.25
	12.5	98.50	117.08	118.12	119.48	121.67	170.78
	16	44.65	63.22	64.26	65.63	67.81	116.93
	20	41.18	59.76	60.80	62.17	64.35	113.46
	25	38.56	57.13	58.17	59.54	61.72	110.84
	31.5	37.10	55.67	56.71	58.08	60.26	109.38
	40	35.98	54.55	55.59	56.96	59.14	108.26

\* **Rapporti speciali / Special ratios / Sonderverhältnisse**

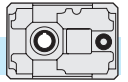





3.7 **Momenti d'inerzia** [Kg.cm<sup>2</sup>]  
(riferiti all'albero veloce in entrata)



3.7 **Moments of inertia** [Kg.cm<sup>2</sup>]  
(referred to input shaft)

3.7 **Trägheitsmoment** [Kg.cm<sup>2</sup>]  
(bez. Antriebswelle)

### ZA..B - ZF..B - ZA..C - ZF..C

180C	$i_n$	ZA 	ZF 			
			IEC B5			
			80	90	110-112	132
50	28.35	32.68	32.93	33.10	47.96	
63	27.03	31.36	31.61	31.78	46.64	
80	26.75	31.08	31.33	31.50	46.36	
100	26.59	30.93	31.17	31.34	46.20	
125	12.10	16.43	16.67	16.85	31.71	
160	11.79	16.13	16.37	16.55	31.41	
200	11.48	15.82	16.06	16.24	31.10	
250	11.46	15.80	16.04	16.21	31.07	

200B	$i_n$	ZA 	ZF 			
			IEC B5			
			132	160	180	200
8	301.72	363.02	371.00	369.00	365.53	
10	285.61	346.91	354.88	352.89	349.41	
12.5	270.18	331.48	339.45	337.46	333.98	
16	114.96	176.26	184.24	182.24	178.77	
20	110.92	172.22	180.19	178.20	174.72	
25	107.05	168.35	176.32	174.33	170.85	
31.5	103.91	165.21	173.19	171.19	167.72	

200C	$i_n$	ZA 	ZF 			
			IEC B5			
			110-112	132	160	180
40	85.01	104.63	105.99	108.17	157.29	
50	84.39	104.00	105.37	107.55	156.67	
63	83.79	103.41	104.77	106.96	156.07	
80	83.31	102.93	104.29	106.47	155.59	
100	34.63	54.25	55.61	57.80	106.91	
125	34.48	54.10	55.46	57.65	106.76	
160	34.36	53.98	55.34	57.52	106.64	



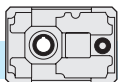

### 3.8 Dimensioni

### 3.8 Dimensions

### 3.8 Abmessungen

	ZA...A						ZA...B - ZF...B - ZA...C - ZF...C																			
	71	90	112	140	180	225	80	100	125	160	180	200														
<b>A</b>	142	180	224	280	360	450	160	200	250	320	360	400														
<b>a</b>	102	134	166	209	272.5	344	82	102	127	162.5	185	204														
<b>a1</b>	—						106	134	169	217	207	277.5														
<b>B</b>	112	127	150	175	215	290	127	150	175	215	255	290														
<b>b</b>	90	104	125	145	180	240	104	125	145	180	210	240														
<b>C2</b>	115	130	155	180	220	300	130	155	180	220	260	300														
<b>D2 H7</b>	24	28	32	30	35	42	40	45	55	50	70	60	100	32	30	35	42	40	45	55	50	70	60	90	80	100
<b>E</b>	206	262	326	407	522.5	654	306	384	479	609.5	652	766.5														
<b>e</b>	38	52	64	82	110	140	42	52	67	90	100	115														
<b>F</b>	9	11	13	15	17	21	11	13	15	17	19	21														
<b>f</b>	M8x13	M10x16	M12x19	M14x21	M16x25	M18x30	M10x16	M12x19	M14x22	M16x25	M18x35	M18x30														
<b>G</b>	122	155	194	244	320	400	135	170	214	280	310	350														
<b>g</b>	61	77.5	97	122	160	200	67.5	85	107	140	155	175														
<b>H</b>	71	90	112	140	180	225	80	100	125	160	180	200														
<b>H1</b>	—						35	36	43	58	58	73														
<b>H2</b>	—						80	100	125	160	160	200														
<b>i</b>	125	159.5	199	249	322.5	404	213.5	269	336	429.5	447	541.5														
<b>O</b>	64	82	102	127	162.5	204	146	184	229	289.5	312	366.5														
<b>O1</b>	—						191	248	311	391.5	414	493.5														
<b>Z</b>	9	11	13	15	17	25	11	13	15	17	22	25														

	ZA...A						ZA...B						ZA...C						
	71	90	112	140	180	225	80	100	125	160	180	200	80	100	125	160	180	200	
<b>D1 h6</b>	19	24	28	38	48	60	19	24	28	38	38	48	14	19	24	28	28	38	38
<b>S</b>	105	127.5	150	190	230	260	105	127.5	150	190	210	230	95	117.5	140	170	190	230	230
<b>U</b>	65	77.5	90	110	150	150	65	77.5	90	110	130	150	65	77.5	90	110	130	150	150
<b>V</b>	40	50	60	80	80	110	40	50	60	80	80	80	30	40	50	60	60	80	80
<b>kg</b>	11.5	18	30.5	52	104	210	18	34	62	114	165	250	20	38	68	125	180	275	275

	ZF...B																		
	80			100			125			160			180			200			
<b>IEC</b>	71	80/90	71	80/90	100/112	80/90	100/112	132	90	100/112	132	160/180	80/90	100/112	132	160/180	132	160/180	200
<b>Y</b>	160	200	160	200	250	200	250	300	200	250	300	350	200	250	300	350	300	350	400
<b>R</b>	151	172	162	182	192	205	215	236	245	255	276	306	266	276	297	327	316	346	348
<b>kg</b>	21		39			72			131			185			280				

	ZF...C																		
	80			100			125			160			180			200			
<b>IEC</b>	63	71	80/90	71	80/90	71	80/90	100/112	80/90	100/112	132	80/90	100/112	132	100/112	132	100/112	132	160/180
<b>Y</b>	140	160	200	160	200	160	200	250	200	250	300	200	250	300	250	300	250	300	350
<b>R</b>	133	140	161	152	173	176	197	207	230	240	261	245	255	276	295	316	316	348	348
<b>kg</b>	23			43			78			142			200			305			

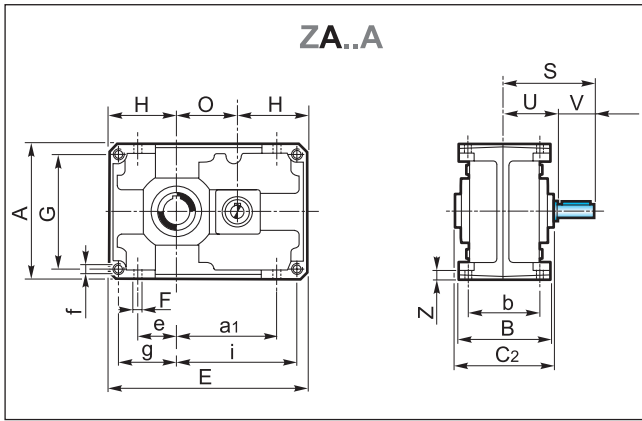
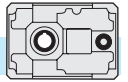

Albero entrata  
Input shaft  
Antriebswelle

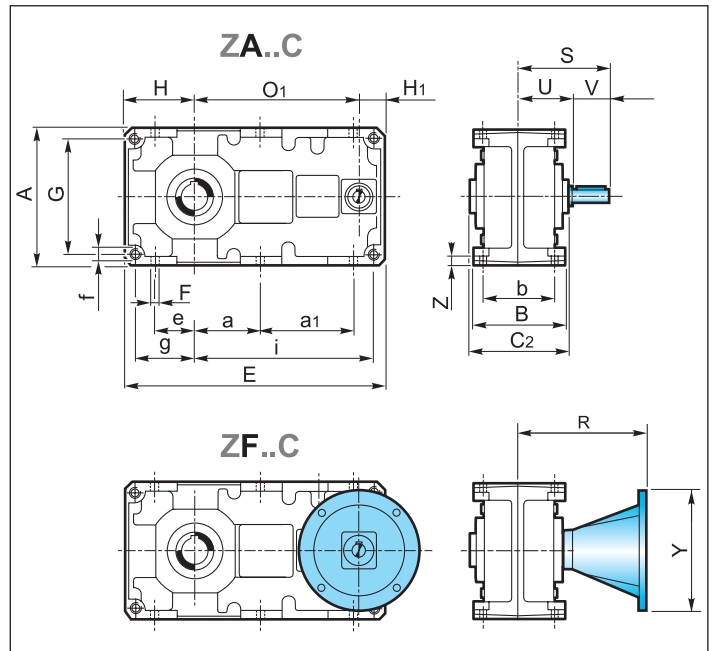
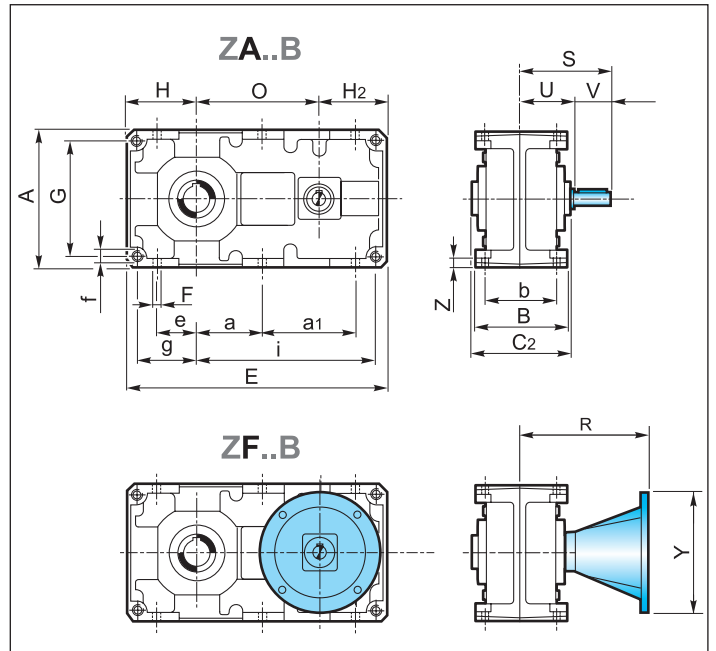
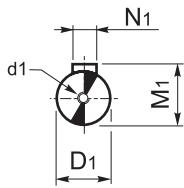

ZA...A		71	90	112	140	180	225
D1 h6		19	24	28	38	48	60
d1		M8	M8	M8	M10	M12	M16
M1		21.5	27	31	41	51.5	64
N1		6	8	8	10	14	18
ZA...B		80	100	125	160	180	200
D1 h6		19	24	28	38	38	48
d1		M8	M8	M8	M10	M10	M12
M1		21.5	27	31	41	41	51.5
N1		6	8	8	10	10	14
ZA...C		80	100	125	160	180	200
D1 h6		14	19	24	28	28	38
d1		M6	M8	M8	M8	M8	M10
M1		16	21.5	27	31	31	41
N1		5	6	8	8	8	10

ZA...A		71	90	112	140	180	225							
C2		115	130	155	180	220	300							
D2 H7	24	28	32	30	35	42	40	45	55	50	70	60	100	90
M2	27.3	31.3	35.3	33.3	38.3	45.3	43.3	48.8	59.3	53.8	74.9	64.4	106.4	95.4
N2	8	8	10	8	10	12	12	14	16	14	20	18	28	25
Z2	—	8.7	8.7	8.4	11	11	11	11	11.9	15.4	15.9	20	-	-
ZA...B - ZF...B - ZA...C - ZF...C		80	100	125	160	180	200							
C2		130	155	180	220	260	300							
D2 H7	32	30	35	42	40	45	55	50	70	60	90	80	100	90
M2	35.3	33.3	38.3	45.3	43.3	48.8	59.3	53.8	74.9	64.4	95.4	85.4	106.4	95.4
N2	10	8	10	12	12	14	16	14	20	18	25	22	28	25
Z2	8.7	8.7	8.4	11	11	11	11.9	15.4	15.9	18.9	18.9	20	-	-

Albero uscita cavo  
Hollow output shaft  
Abtriebshohlwelle

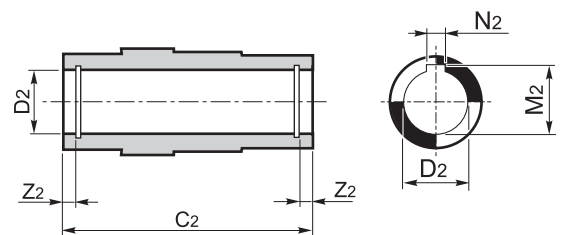

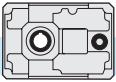

### 3.9 Seconda entrata

A richiesta è possibile fornire il riduttore con entrata supplementare.

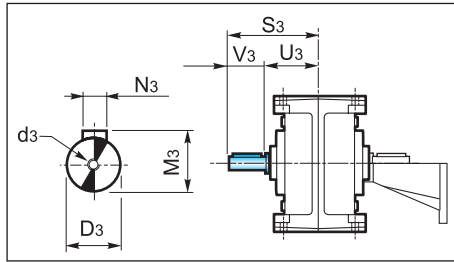

### 3.9 Second input

On request it is possible to supply the gearbox with an additional input.

### 3.9 Zweiter Antrieb

Auf Wunsch ist das Getriebe mit Zusatzantrieb lieferbar.

	ZA...											
	80B	100B	125B	160B	180B	200B	80C	100C	125C	160C	180C	200C
D3 <sub>g6</sub>	14	19	24	28	28	38	14	14	19	24	24	28
d3	M6	M8	M8	M8	M8	M10	M6	M6	M8	M8	M8	M8
N3	5	6	8	8	8	10	5	5	6	8	8	8
M3	16.3	21.8	27.3	31.3	31.3	41.3	16.3	16.3	21.8	27.3	27.3	31.3
S3	95	117.5	140	170	190	230	95	107.5	130	160	180	210
U3	65	77.5	90	110	130	150	65	77.5	90	110	130	150
V3	30	40	50	60	60	80	30	30	40	50	50	60

### 3.10 Accessori

#### Albero lento

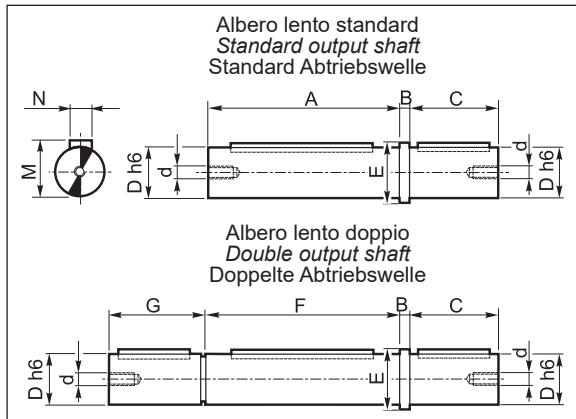

### 3.10 Accessories

#### Output shaft

### 3.10 Zubehör

#### Abtriebswelle

	Z...						
	71A	90A 80B 80C	112A 100B 100C	140A 125B 125C	180A 160B 160C	180B 180C	225A 200B 200C
A	114	129	129	154	154	179	219
B	5	6	6	8	8	10	12
C	50	60	60	80	80	100	125
D <sub>h6</sub>	24	32	35	42	45	55	70
d	M8	M8	M8	M10	M10	M10	M12
E	30	40	43	50	53	65	80
F	115	130	—	155	—	180	220
G	49	59	—	79	—	99	124
M	27	35	38	45	48.5	59	74.5
N	8	10	10	12	14	16	20

Materiale albero lento: C45 - Output shaft material: C45 - Material der Abtriebswelle: C45

### Kit fissaggio e smontaggio riduttori con albero lento cavo

### Kit for the mounting and dismounting of the gearboxes with hollow output shaft

### Kit für Montage und Ausbau der Getriebe mit Abtriebshohlwelle

	Z												
	90A 80B 80C			112A 100B 100C			140A 125B 125C		180A 160B 160C		180B 180C		225A 200B 200C
C2	130			155			180		220		260		300
D2	32	30	35	42	40	45	55	50	70	60	90	80	100
H	8	7	6.5	10	8		9		12		16	15.5	17
d1	—			—			M10		M12		M16		M18
d2	—			—			M8		M10		M12		M16
d3	M8			M8			—		—		—		—
d4	M12			M12			—		—		—		—
Z2	8.7		8.4	10.7			11.9		15.4	15.9	18.9	19.4	16.9
Lmax	111	112		131	133		156		189		221		262
Lmin	106	107		126	128		149		182		211		252

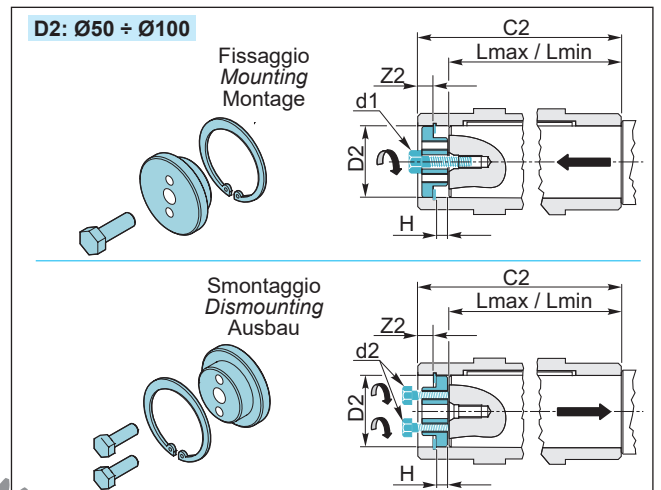
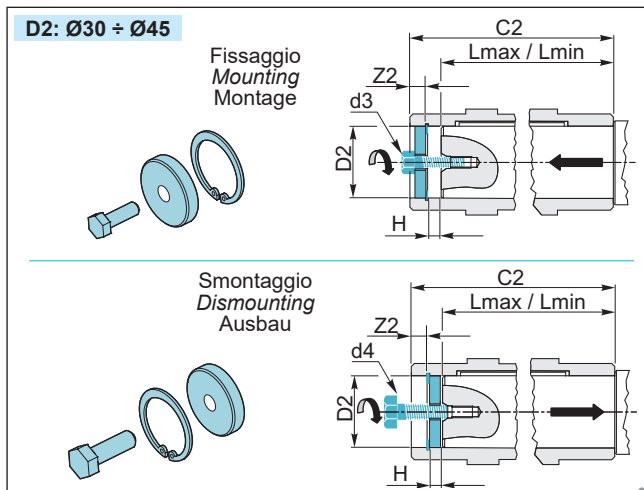

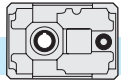

### Albero lento cavo con calettatore

### Hollow output shaft with shrink disc

### Abtriebshohlwelle mit Schrumpfscheibe

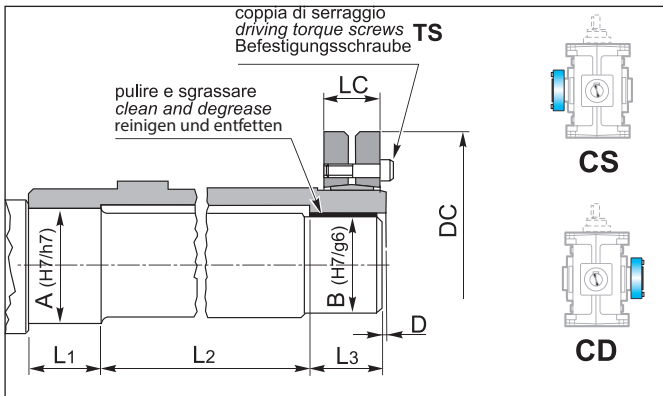

	Z						
	71A	90A 80B 80C	112A 100B 100C	140A 125B 125C	180A 160B 160C	180B 180C	225A 200B 200C
A	27	37	47	57	72	92	102
B	25	35	45	55	70	90	100
D	2	2	2	2	2	3	3
DC	60	80	100	115	155	188	215
LC	22	26	31	31	39	50	54
L <sub>1</sub>	36	39	45	50	60	70	80
L <sub>2</sub>	68	82	100	115	143	175	200
L <sub>3</sub>	36	39	45	50	60	70	80
TS (Nm)	4	12	12	12	30	59	59

### Kit protezione albero cavo

### Hollow shaft protection kit

### Schutzvorrichtung für die Hohlwelle

A richiesta è possibile predisporre il riduttore con un kit di protezione dell'albero cavo. Tale protezione, essendo dotata di un'opportuna guarnizione, impedisce ad eventuali fluidi, presenti nell'ambiente di lavoro, di venire a contatto con l'albero cavo del riduttore oltre ad impedire il contatto con corpi estranei. Le dimensioni di ingombro sono riportate nella tabella seguente.

On request we can supply a hollow shaft protection kit. The kit features a gasket which prevents any contact between hollow shaft and foreign bodies or fluids existing in the working environment. Over-all dimensions are reported in the following table.

Auf Wunsch ist eine Schutzvorrichtung für die Hohlwelle lieferbar. Die Schutzvorrichtung weist eine Dichtung auf, die zur Vermeidung von irgendwelchem Kontakt zwischen Hohlwelle und Fremdkörper oder Flüssigkeiten der Arbeitsumgebung dient. In der folgenden Tabelle wird den Raumbedarf angegeben.

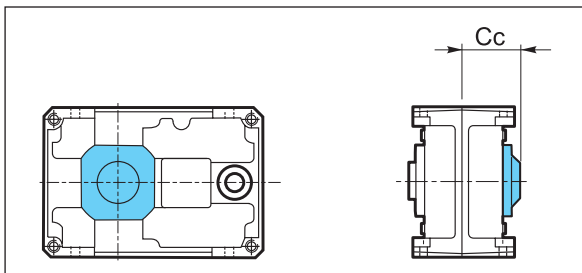

	Z						
	71A	90A 80B 80C	112A 100B 100C	140A 125B 125C	180A 160B 160C	180B 180C	225A 200B 200C
Cc	79.5	87	105	120.5	141.5	167.5	191.5

### Flangia uscita

### Output flange

### Abtriebsflansch

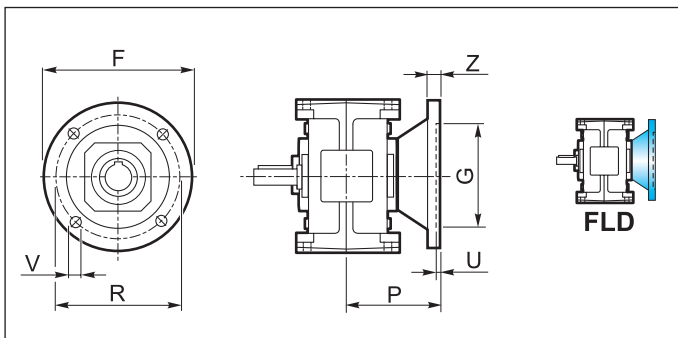

	Z...					
	71A	90A 80B 80C	112A 100B 100C	140A 125B 125C	180A 160B 160C	180B 180C
F	160	200	250	300	350	400
G <sub>F7</sub>	110	130	180	230	250	300
R	130	165	215	265	300	350
P	87	100	125	150	180	215
U	4	4.5	5	5	6	6
V	12	12	14	16	18	20
Z	10	12	16	20	25	30
kg	2	3.2	5	8	12.5	24

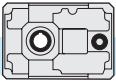

### Braccio di reazione

### Torque arm

### Drehmomentstütze

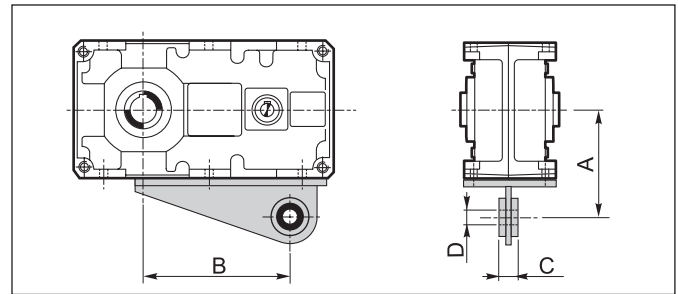
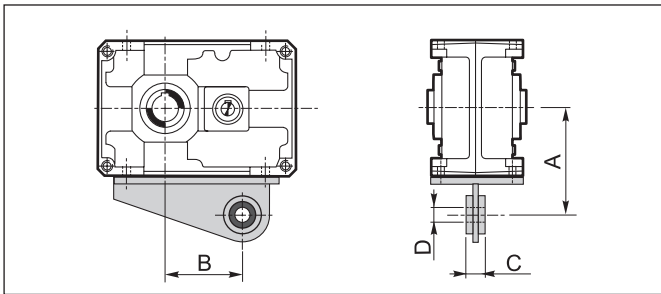

	Z					
	71A	90A	112A	140A	180A	225A
A	123	140	172	205	260	325
B	84	116	144	189	247.5	319
C	25	25	30	30	35	45
D	20	20	25	25	35	40

	Z					
	80B 80C	100B 100C	125B 125C	160B 160C	180B 180C	200B 200C
A	130	160	190	240	280	300
B	170	214	276	354.5	367	456.5
C	25	30	30	35	45	45
D	20	25	25	35	40	40

### Dispositivo antiritorno

### Backstop device

### Rücklaufsperre

Il riduttore ad assi paralleli presenta valori di rendimento statico (e dinamico) molto elevati: per questo motivo non è garantita spontaneamente l'irreversibilità statica. L'irreversibilità statica si realizza quando, a riduttore fermo, l'applicazione di un carico all'albero lento non pone in rotazione l'asse entrata. Pertanto, per garantire l'irreversibilità del moto, a riduttore fermo, occorre predisporre il riduttore stesso con un opportuno dispositivo antiritorno, fornibile a richiesta solo nel caso di riduttore a 2 o 3 stadi di riduzione (Z..B e Z...C). Tale dispositivo permette la rotazione dell'albero lento solo nel senso desiderato, da specificare all'atto dell'ordine.

*Parallel shaft gearboxes feature quite high values of static (and dynamic) efficiency: for this reason spontaneous static irreversibility is not guaranteed. Static irreversibility, with motionless gearbox, occurs when the application of a load on the output shaft does not cause rotation of the input axis. In order to guarantee motion irreversibility, with motionless gearbox, it is necessary to fit a backstop device, which is available on request only for gearbox with 2 or 3 reduction stages (Z..B and Z...C). The backstop device enables rotation of the output shaft only in the required direction, which is to be specified when ordering.*

Parallelengetriebe haben sehr hohen statischen (und dynamischen) Wirkungsgrade: deshalb wird keine spontane statische Irreversibilität garantiert. Statische Irreversibilität bei stillstehenden Getriebe hat man, wenn die Applikation einer Last auf die Abtriebswelle keine Drehung der Antriebswelle verursacht. Um Irreversibilität der Bewegung bei stillstehendem Getriebe zu sichern, soll eine Rücklaufsperre montiert werden. Die Rücklaufsperre wird auf Wunsch nur für Getriebe mit entweder 2 oder 3 Unterstufungsstufen (Z.B und Z...C) geliefert. Die Rücklaufsperre ermöglicht, dass die Abtriebswelle nur in der gewünschten Richtung dreht (gewünschte Richtung beim Bestellen angeben).

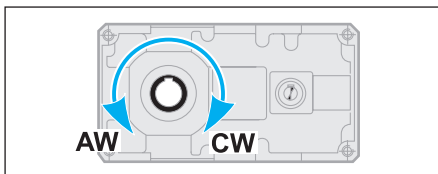

- CW** Rotazione oraria  
Clockwise rotation  
Im Uhrzeigersinn
- AW** Rotazione antioraria  
Anti-clockwise rotation  
Gegen den Uhrzeigersinn

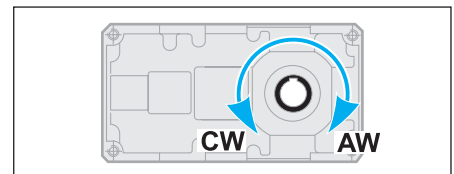

Nel caso in cui sia presente il dispositivo antiritorno è necessario l'utilizzo di olio lubrificante sintetico, classe di viscosità ISO 150.

**The utilization of synthetic oil, viscosity class ISO 150, is necessary for the gearboxes equipped with back stop device.**

**Getriebe mit einer Rücklaufsperre müssen mit synthetischem Öl (Viskosität ISO150) betrieben werden.**

Nella tabella seguente (tab 3) sono indicati i valori dei momenti torcenti nominali massimi ( $T_{2Mmax}$ ), riferiti all'albero uscita, garantiti dal dispositivo di antiritorno, per ogni rapporto di riduzione e per ogni grandezza di riduttore. Se, in corrispondenza dell'albero lento, viene applicata una coppia maggiore di quella indicata, l'irreversibilità del moto non è più garantita. Questi valori di coppia non sono da confondere con quelli riportati nella tabella riguardante i dati tecnici dei riduttori. Infatti, si noti come in tabella siano stati messi in evidenza i valori di coppia garantiti (in uscita) dal dispositivo antiretro che risultano essere minori dei massimi valori di coppia motrice trasmissibili, con fattore di servizio  $F_s = 1$ , dal riduttore.

*The following table (tab.3) shows the max. rated torques ( $T_{2Mmax}$ ) at gearbox output guaranteed by the backstop device, for each ratio and each gearbox size. If a higher torque is applied at gearbox output, motion irreversibility is no longer guaranteed.*

In der folgenden Tabelle (Tab. 3) werden die max. Nenn Drehmomente am Abtrieb angegeben ( $T_{2Mmax}$ ), die die Rücklaufsperre je nach Unterstufungsverhältnis und Getriebegröße garantiert. Falls am Abtrieb ein höheres Drehmoment eingesetzt wird, dann ist die Irreversibilität der Bewegung nicht mehr garantiert.

*These torque values are not to be confused with the values reported in the gearbox specifications tables. Please note that the torque values guaranteed (at output) by the backstop device are lower than the max. driving torque values transmissible by the gearbox, with service factor  $F_s = 1$ .*

Diese Drehmomente sind nicht mit den Werten zu verwechseln, die in der Tabelle der technischen Daten der Getriebe angegeben werden.

Die von der Rücklaufsperre (am Abtrieb) garantierten Drehmomente sind niedriger als die von Getriebe übersetzbaren max. Drehmomente, unter Berücksichtigung eines Betriebsfaktors  $F_s = 1$ .

Vedere paragrafo 1.5 per la verifica del dispositivo antiritorno.

**To check the back stop device pls see paragraph 1.5.**

**Für die Überprüfung der Rücklaufsperre siehe Abschnitt 1.5.**

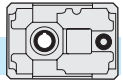

**Coppia massima garantita in uscita dal dispositivo antiritorno**  
**Max. output torque guaranteed by the backstop device**  
**Von der Rücklauf Sperre garantierten max. Abtriebsdrehmomente**

Tab. 3

	$T_{2M} \text{ max}$ [Nm]													
	8	10	12.5	16	18*	20	25	31.5	35*	40	45*	50	56*	63
<b>Z80B</b>	—	544	692	830	—	1086	1301	1656	—	1985	—	2566	—	3319
<b>Z100B</b>	—	850	1082	1297	—	1697	2033	2588	—	3101	—	4010	—	5186
<b>Z125B</b>	—	1870	2380	2853	3179	3733	4473	5693	6347	6822	7605	8822	9836	11409
<b>Z160B</b>	—	3944	5019	6017	6706	7873	9435	12006	13389	14388	16042	18606	20747	24062
<b>Z180B</b>	6093	7808	9433	11705	—	15594	18828	23357	—	31608	—	—	—	—
<b>Z200B</b>	6266	7522	9245	12509	—	15022	18452	22597	—	—	—	—	—	—

	$T_{2M} \text{ max}$ [Nm]											
	40	50	63	80	90*	100	125	160	180*	200	250	280*
<b>Z80C</b>	—	1400	1678	2135	—	2814	3371	4291	—	5550	6650	—
<b>Z100C</b>	—	2770	3318	4223	—	5529	6625	8432	—	10905	13066	—
<b>Z125C</b>	—	4328	5185	6599	7358	8639	10352	13175	14689	17038	20416	22763
<b>Z160C</b>	—	9521	11407	14518	16185	19006	22774	28985	37488	37484	44915	50072
<b>Z180C</b>	—	9689	11702	14518	—	18134	22497	28985	—	36201	44915	—
<b>Z200C</b>	16399	19693	24186	29615	—	39316	48283	59125	—	—	—	—

Valori di coppia garantiti inferiori alla  $T_{2M}$     Torque values guaranteed lower than  $T_{2M}$  value    Zuverlässige Drehmomente unter  $T_{2M}$  Wert

\* **Rapporti speciali / Special ratios / Sonderverhältnisse**

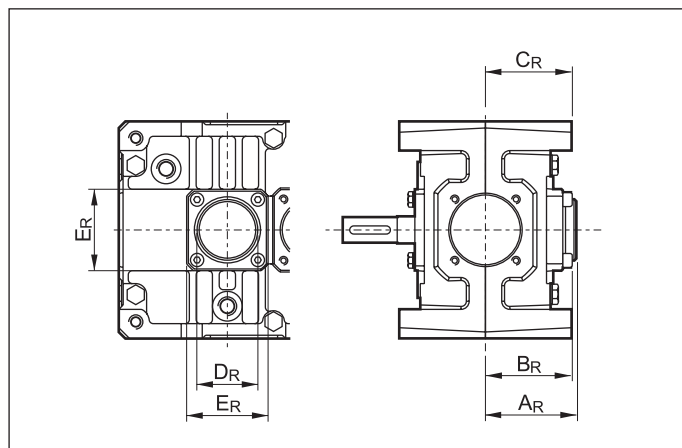

	$A_R$	$B_R$	$C_R$	$D_R$	$E_R$
<b>Z 80C</b>	59	57	63.5	52	60
<b>Z 80B</b>	67	56	63.5	45	60
<b>Z 100C</b>	72	61	75	45	60
<b>Z 100B</b>	71.5	63.5	75	55	80
<b>Z 125C</b>	86.5	78.5	87.5	55	80
<b>Z 125B</b>	86.5	81	87.5	60	90
<b>Z 160C</b>	96.5	91	107.5	60	90
<b>Z 180B</b>	127	114	127.5	80	100
<b>Z 180C</b>	108	108	127.5	60	90
<b>Z 160B</b>	106.5	95	107.5	70	100
<b>Z 200C</b>	126.5	115	145	70	100
<b>Z 200B</b>	125	116	145	90	130

Dimensioni riferite alla versione con antiretro    Dimensions of the version with backstop device    Abmessungen der Version mit Rücklauf Sperre

**3.11 Giochi angolari**

Bloccando l'albero di entrata, il gioco viene misurato sull'albero uscita ruotandolo nelle due direzioni ad applicando la coppia strettamente necessaria a creare il contatto tra i denti degli ingranaggi, al massimo pari al 2% della coppia massima garantita dal riduttore. Nella tabella seguente sono riportati i valori indicativi del gioco angolare (in minuti di angolo).

**3.11 Angular backlash**

After having blocked the input shaft, the angular backlash can be measured on the output shaft by rotating it in both directions and applying the torque which is strictly necessary to create a contact between the teeth of the gears. The applied torque should be at most 2% of the max. torque guaranteed by the gearbox. The following table reports the approximate values of the angular backlash (in minutes of arc).

**3.11 Winkelspiel**

Nachdem die Antriebswelle blockiert worden ist, kann das Winkelspiel an der Abtriebswelle gemessen werden. Dabei soll die Abtriebswelle in beiden Richtungen gedreht und ein Drehmoment ausgeübt werden, das zur Entstehen eines Kontaktes zwischen den Zähnen genügt. Das ausgeübte Drehmoment soll höchstens 2% des max. vom Getriebe garantierten Drehmoment sein. Die folgende Tabelle zeigt die Näherungswerte des Winkelspiels (in Bogenminuten).

<b>Gioco angolare / Backlash / Winkelspiel (1')</b>					
<b>Z..A</b>	10-16	<b>Z..B</b>	16-20	<b>Z..C</b>	20-25

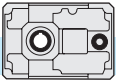

### 3.12 Lubrificazione

I riduttori ad assi paralleli sono forniti predisposti per lubrificazione a olio e muniti dei tappi di carico, livello e scarico olio. Si raccomanda di precisare sempre la posizione di montaggio desiderata in fase di ordine.

#### POMPA OLIO

Una pompa per lubrificazione forzata dei cuscinetti superiori è fornita a richiesta sulle grandezze 125, 140, 160, 180, 200 e 225 nella posizione di montaggio VA.

#### Posizione di montaggio e quantità di lubrificante (litri)

Nella posizione di montaggio V1-V3 è previsto un tappo di sfiato con asta di livello.

I quantitativi di olio riportati nelle varie tabelle sono indicativi e riferiti alle posizioni di lavoro indicate e considerando le condizioni di funzionamento a temperatura ambiente e velocità in ingresso di 1400 min<sup>-1</sup>. Per condizioni di lavoro diverse da quelle sopra riportate contattare il servizio tecnico.

### 3.12 Lubrication

*Parallel shaft gearboxes require oil lubrication and are equipped with filler, level and drain plugs. The mounting position should always be specified when ordering the gearbox.*

#### OIL PUMP.

*A pump for forced lubrication of the upper bearings is supplied on request for sizes 125, 140, 160, 180, 200 and 225 in the VA mounting position.*

#### Mounting positions and lubricant quantity (liters)

*In mounting position V1-V3 the breather is fitted with dipstick.*

*The oil quantities stated in the tables are approximate values and refer to the indicated working positions, considering operating conditions at ambient temperature and an input speed of 1400 min<sup>-1</sup>. Should the operating conditions be different, please contact the technical service.*

### 3.12 Schmierung

Parallelengetriebe sind für Ölschmierung mit Einfüll-, Ölstand- und Ablassstopfen versehen.

Bei der Bestellung ist immer die gewünschte Montageposition anzugeben.

#### ÖLPUMPE.

Eine Pumpe für die Zwangsschmierung der oberen Lager wird auf Wunsch bei den Größen 125, 140, 160, 180, 200 und 225 in der Montageposition VA geliefert.

#### Montageposition und Ölmenge (liter)

Für die V1-V3 Version ist eine Entlüftungsschraube mit Ölstandanzeiger vorausgesehen.

Die in der Tabellen angegebenen Daten sind Richtwerte. Die Ölmenge beziehen sich auf die angegebene Betriebsposition. Dabei werden Betrieb bei Umgebungstemperatur und Antriebsdrehzahl von 1400 min<sup>-1</sup> berücksichtigt. Falls die Betriebsbedingungen anders sind, dann ist das technische Büro zu befragen.

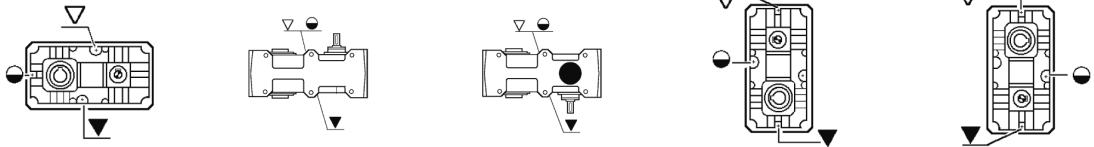

Z	B3	V1	V3	VA	VB
71A	0.6	0.75	0.75	0.6	0.7
80B - 80C	1.1	1.5	1.5	1.5	1.5
90A	1.2	1.5	1.5	1.2	1.3
100B - 100C	2.0	2.6	2.6	2.8	2.8
112A	2.0	2.6	2.6	2.0	2.2
125B - 125C	3.8	4.8	4.8	5.0	5.0
140A	3.7	4.8	4.8	3.7	4.0
160B - 160C	7.0	9.2	9.2	10	10.0
180A	7.1	9.2	9.2	7.1	7.8
180B - 180C	9.5	14.0	13.0	15.5	16.0
200B -200C	13.5	19.0	19.0	19.5	19.5
225A	13.5	17.5	17.5	13.5	14.8

#### Posizione morsettiera

#### Terminal board position

#### Lage des Klemmenkastens

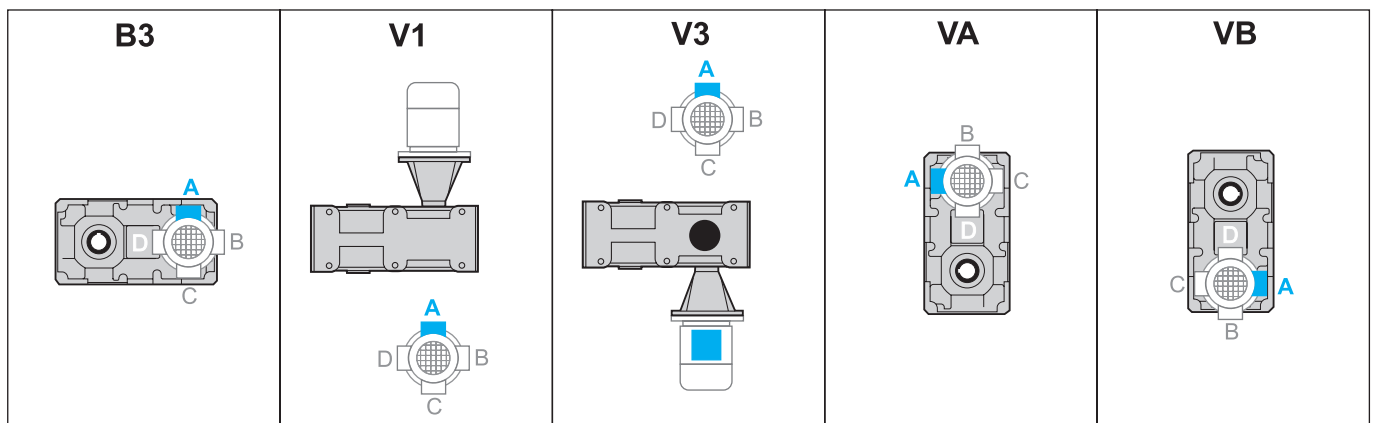

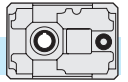

### 3.13 Carichi radiali e assiali (N)

Le trasmissioni effettuate tramite pignoni per catena, ruote dentate o pulegge generano delle forze radiali ( $F_R$ ) sugli alberi dei riduttori. L'entità di tali forze può essere calcolata con la formula:

### 3.13 Radial and axial loads (N)

Transmissions implemented by means of chain pinions, wheels or pulleys generate radial forces ( $F_R$ ) on the gear unit shafts. The entity of these forces may be calculated using the following formula:

### 3.13 Radial- und Axialbelastungen (N)

Antriebe mit Kettenritzel, Zahnrädern oder Riemenscheiben erzeugen radiale Kräfte ( $F_R$ ) an den Wellen der Untersetzungsgetriebe. Das Ausmaß dieser Kräfte kann nach folgender Formel berechnet werden:

$$F_R = \frac{K_R \cdot T}{d} \text{ [N]}$$

dove:

T = Momento torcente [Nm]  
d = Diametro pignone o puleggia [mm]

$K_R$  = 2000 per pignone per catena  
= 2500 per ruote dentate  
= 3000 per puleggia con cinghie a V

where:

T = torque [Nm]  
d = pinion or pulley diameter [mm]

$K_R$  = 2000 for chain pinion  
= 2500 for wheel  
= 3000 for V-belt pulley

dabei ist:

T = Drehmoment [Nm]  
d = Kettenritzel- bzw. Riemenscheiben  
durchmesser [mm]

$K_R$  = 2000 bei Kettenritzel  
= 2500 bei Zahnrad  
= 3000 bei Riemenscheibe mit  
Keilriemen

I valori dei carichi radiali e assiali generati dall'applicazione debbono essere sempre minori o uguali a quelli ammissibili indicati nelle tabelle.

The values of the radial and axial loads generated by the application must always be lower than or equal to the admissible values reported in the tables.

Die Werte der Radial- und Axialbelastungen, die durch die Anwendung hervorgerufen werden, dürfen nicht über den in den Tabellen angegebenen zulässigen Werten liegen.

$$F_R \geq Fr_{1-2}$$

Se il carico radiale sull'albero non è applicato a metà della sporgenza dell'albero, il valore del carico ammissibile deve essere valutato utilizzando la formula che si riferisce ad  $F_{r_{1-2}}$ , in cui i valori di a, b e  $F_{r_{1-2}}$  sono riportati nelle tabelle relative ai carichi radiali.

Nel caso di alberi bisporgenti il valore del carico applicabile a ciascuna estremità è uguale ai 2/3 del valore di tabella, purché i carichi applicati siano uguali di intensità e direzione ed agiscano nello stesso senso. Diversamente contattare il servizio tecnico.

Should the radial load affect the shaft not at the half-way point of its projection but at a different point, the value of the admissible load has to be calculated using the  $F_{r_{1-2}}$  formula: a, b and  $F_{r_{1-2}}$  values are reported in the radial load tables.

With regard to double-projecting shafts, the load applicable at each end is 2/3 of the value given in the table, on condition that the applied loads feature same intensity and direction and that they act in the same direction.

Otherwise please contact the technical department.

Falls die Radialbelastungen nicht in dem Mittelpunkt der herausragenden Welle sondern in einem anderen Punkt wirken, soll die zulässige Belastung mit der Formel bezüglich  $F_{r_{1-2}}$  kalkuliert werden: a, b und  $F_{r_{1-2}}$  Werte sind aus der Tabelle der Radialbelastungen zu entnehmen.

Bei doppelseitigen Wellen ist die Belastung, die an jedem Ende anwendbar ist, 2/3 des in der Tabelle angegebenen Wertes unter der Bedingung, daß sie in dieselbe Richtung wirken. Andernfalls muß mit dem technischen Büro Rücksprache gehalten werden.

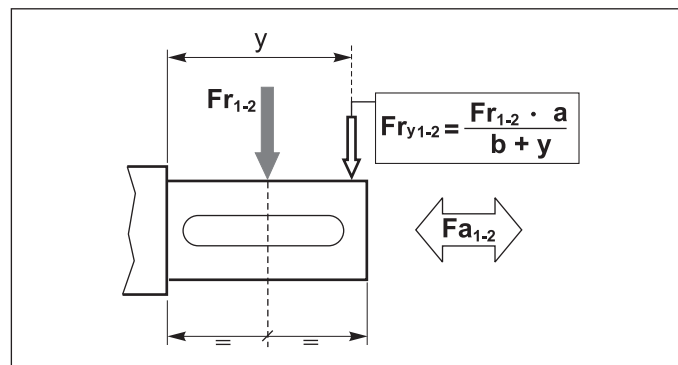



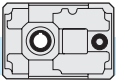

Tab. 6

	Z 71A		Z 90A		Z 112A		Z 140A		Z 180A		Z 225A	
ALBERO ENTRATA / INPUT SHAFT / ANTRIEBSWELLE ( $n_1 = 1400 \text{ min}^{-1}$ )												
in	a=118.25	b=98.25	a=140.25	b=115.25	a=155.25	b=125.25	a=203.75	b=163.75	a=253.75	b=213.75	a=281.25	b=226.25
	Fr <sub>1</sub>	Fa <sub>1</sub>	Fr <sub>1</sub>	Fa <sub>1</sub>	Fr <sub>1</sub>	Fa <sub>1</sub>	Fr <sub>1</sub>	Fa <sub>1</sub>	Fr <sub>1</sub>	Fa <sub>1</sub>	Fr <sub>1</sub>	Fa <sub>1</sub>
<b>Tutti All Alle</b>	400	80	630	125	1000	200	1600	320	2500	500	4000	800
ALBERO USCITA / OUTPUT SHAFT / ABTRIEBSWELLE ( $n_1 = 1400 \text{ min}^{-1}$ )												
in	a=114.5	b=84.5	a=131	b=95	a=161.5	b=113.5	a=192	b=132	a=236.5	b=162	a=325	b=220
	Fr <sub>2</sub>	Fa <sub>2</sub>	Fr <sub>2</sub>	Fa <sub>2</sub>	Fr <sub>2</sub>	Fa <sub>2</sub>	Fr <sub>2</sub>	Fa <sub>2</sub>	Fr <sub>2</sub>	Fa <sub>2</sub>	Fr <sub>2</sub>	Fa <sub>2</sub>
<b>5</b>	2550	510	4000	800	6450	1290	10150	2030	16400	3280	32800	6560
<b>6.3</b>	2700	540	4250	850	6800	1360	10700	2140	—	—	—	—
<b>8</b>	2850	570	4500	900	7150	1430	11250	2250	—	—	—	—

	Z 80B		Z 100B		Z 125B		Z 160B		Z 180B		Z 200B	
ALBERO ENTRATA / INPUT SHAFT / ANTRIEBSWELLE ( $n_1 = 1400 \text{ min}^{-1}$ )												
in	a=118.25	b=98.25	a=140.25	b=115.25	a=155.25	b=125.25	a=203.75	b=163.75	a=231.75	b=191.75	a=253.75	b=213.75
	Fr <sub>1</sub>	Fa <sub>1</sub>	Fr <sub>1</sub>	Fa <sub>1</sub>	Fr <sub>1</sub>	Fa <sub>1</sub>	Fr <sub>1</sub>	Fa <sub>1</sub>	Fr <sub>1</sub>	Fa <sub>1</sub>	Fr <sub>1</sub>	Fa <sub>1</sub>
<b>Tutti All Alle</b>	400	80	630	125	1000	200	1600	320	2000	500	2500	500
ALBERO USCITA / OUTPUT SHAFT / ABTRIEBSWELLE ( $n_1 = 1400 \text{ min}^{-1}$ )												
in	a=131	b=95	a=161.5	b=113.5	a=192	b=132	a=236.5	b=162	a=265.5	b=191	a=325	b=220
	Fr <sub>2</sub>	Fa <sub>2</sub>	Fr <sub>2</sub>	Fa <sub>2</sub>	Fr <sub>2</sub>	Fa <sub>2</sub>	Fr <sub>2</sub>	Fa <sub>2</sub>	Fr <sub>2</sub>	Fa <sub>2</sub>	Fr <sub>2</sub>	Fa <sub>2</sub>
<b>8</b>									26800	5360	38000	7600
<b>10</b>	4750	950	7500	1500	11800	2360	19000	3800	28800	5760	40000	8000
<b>12.5</b>	5000	1000	8000	1600	12500	2500	20000	4000	30400	6080	42400	8480
<b>16</b>	5300	1060	8500	1700	13200	2640	21200	4240	32200	6440	44800	8960
<b>18*</b>	—	—	—	—	13600	2720	21800	4360	—	—	—	—
<b>20</b>	5600	1120	9000	1800	14000	2800	22400	4480	34000	6800	47200	9440
<b>25</b>	6000	1200	9500	1900	15000	3000	23600	4720	35800	7160	50000	10000
<b>31.5</b>	6300	1260	10000	2000	16000	3200	25000	5000	37600	7520	53000	10600

\* Rapporti speciali / Special ratios / Sonderverhältnisse

	Z 80C		Z 100C		Z 125C		Z 160C		Z 180C		Z 200C	
ALBERO ENTRATA / INPUT SHAFT / ANTRIEBSWELLE ( $n_1 = 1400 \text{ min}^{-1}$ )												
in	a=115.5	b=100.05	a=135.75	b=115.75	a=167.75	b=142.75	a=195.25	b=165.25	a=226.75	b=196.75	a=263.75	b=223.75
	Fr <sub>1</sub>	Fa <sub>1</sub>	Fr <sub>1</sub>	Fa <sub>1</sub>	Fr <sub>1</sub>	Fa <sub>1</sub>	Fr <sub>1</sub>	Fa <sub>1</sub>	Fr <sub>1</sub>	Fa <sub>1</sub>	Fr <sub>1</sub>	Fa <sub>1</sub>
<b>Tutti All Alle</b>	315	60	400	80	630	125	1000	400	1250	250	1600	320
ALBERO USCITA / OUTPUT SHAFT / ABTRIEBSWELLE ( $n_1 = 1400 \text{ min}^{-1}$ )												
in	a=131	b=95	a=161.5	b=113.5	a=192	b=132	a=236.5	b=162	a=265.5	b=191	a=325	b=220
	Fr <sub>2</sub>	Fa <sub>2</sub>	Fr <sub>2</sub>	Fa <sub>2</sub>	Fr <sub>2</sub>	Fa <sub>2</sub>	Fr <sub>2</sub>	Fa <sub>2</sub>	Fr <sub>2</sub>	Fa <sub>2</sub>	Fr <sub>2</sub>	Fa <sub>2</sub>
<b>Tutti All Alle</b>	7500	1500	11800	2360	19000	3800	30000	6000	43000	8600	53000	10600

I carichi radiali indicati nelle tabelle si intendono applicati a metà della sporgenza dell'albero e sono riferiti ai riduttori operanti con fattore di servizio 1.

The radial loads reported in the tables are considered to be applied at the half-way point of the shaft projection and refer to gear units operating with service factor 1.

Die in den Tabellen angegebenen Radialbelastungen gelten für Ansatzpunkte in der Mitte des herausragenden Wellenteils und für Getriebe mit Betriebsfaktor 1.



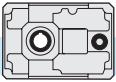

**ZA..B - ZF..B**

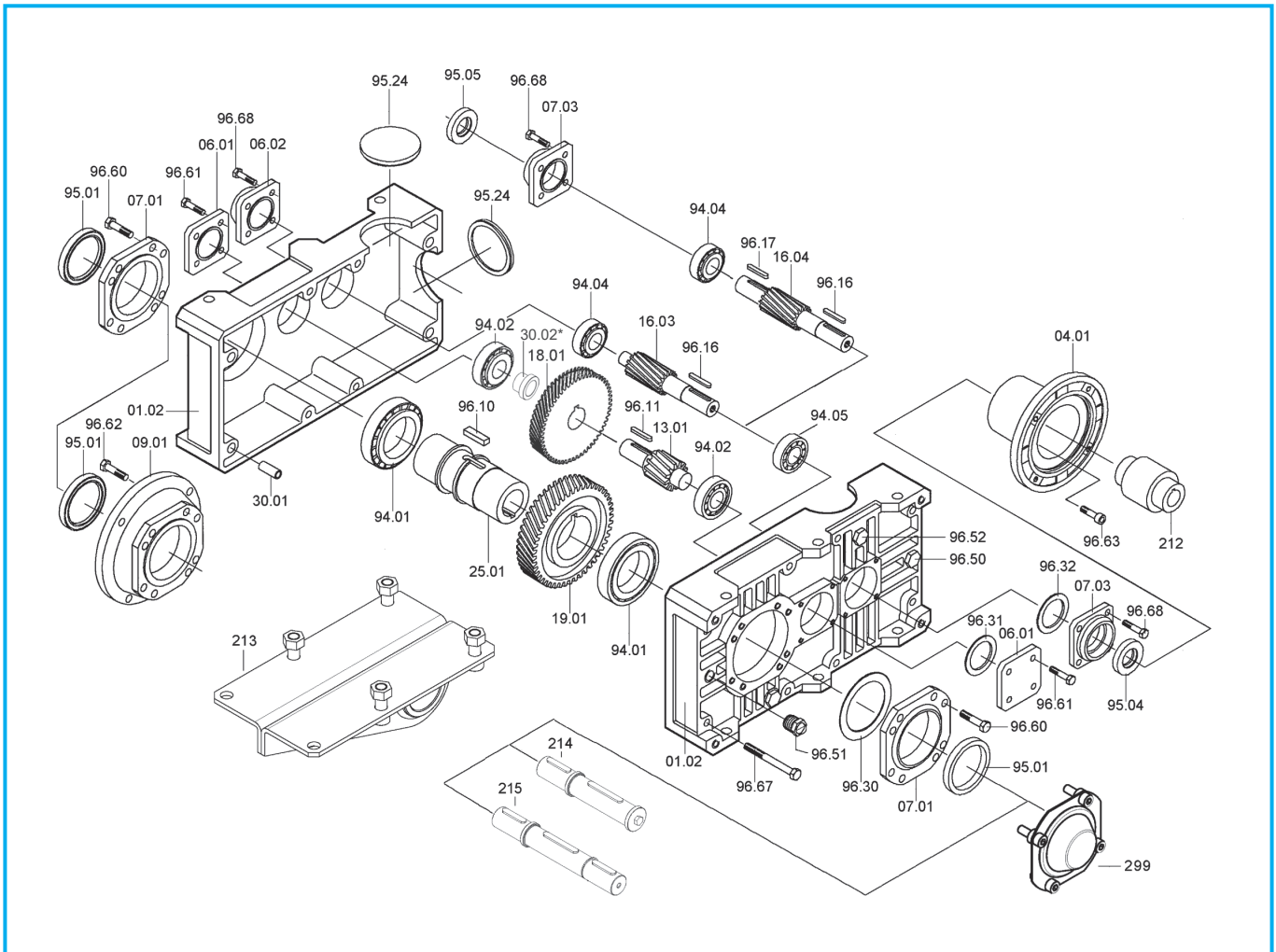

ZA - ZF	Cuscinetti / Bearings / Lager				Anelli di tenuta / Oilseals / Öldichtungen		
	94.01	94.02	94.04	94.05	95.01	95.04	95.05
<b>80B</b>	<b>32010</b> 50/80/20	<b>30204</b> 20/47/15.25	<b>30302</b> 15/42/14.25	<b>32004</b> 20/42/15	50/65/8	<b>20/40/7</b>	<b>15/40/10</b>
<b>100B</b>	<b>32012</b> 60/95/23	<b>30305</b> 25/62/18.25	<b>30204</b> 20/47/15.25	<b>32005</b> 25/47/15	60/80/10	<b>25/47/7</b>	<b>20/47/7</b>
<b>125B</b>	<b>32015</b> 75/115/25	<b>32206</b> 30/62/21.25	<b>30305</b> 25/62/18.25	<b>30206</b> 30/62/17.25	75/95/10	<b>30/52/7</b>	<b>25/52/7</b>
<b>160B</b>	<b>32019</b> 95/145/32	<b>32207</b> 35/72/24.25	<b>32206</b> 30/62/21.25	<b>32008</b> 40/68/19	95/125/12	<b>40/56/8</b>	<b>30/56/10</b>
<b>180B</b>	<b>32024</b> 120/180/38	<b>31309</b> 45/100/27.25	<b>30307</b> 35/80/22.75	<b>32208</b> 40/80/24.75	120/160/15	<b>40/62/7</b>	<b>35/62/7</b>
<b>200B</b>	<b>32026</b> 130/200/45	<b>31310</b> 50/110/29.25	<b>32208</b> 40/80/24.75	<b>32010</b> 50/80/20	130/160/12	<b>50/65/8</b>	<b>40/65/10</b>

\*Solo per Z180B / Only for Z180B / Nur für Z180B

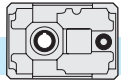

## ZA..C - ZF..C

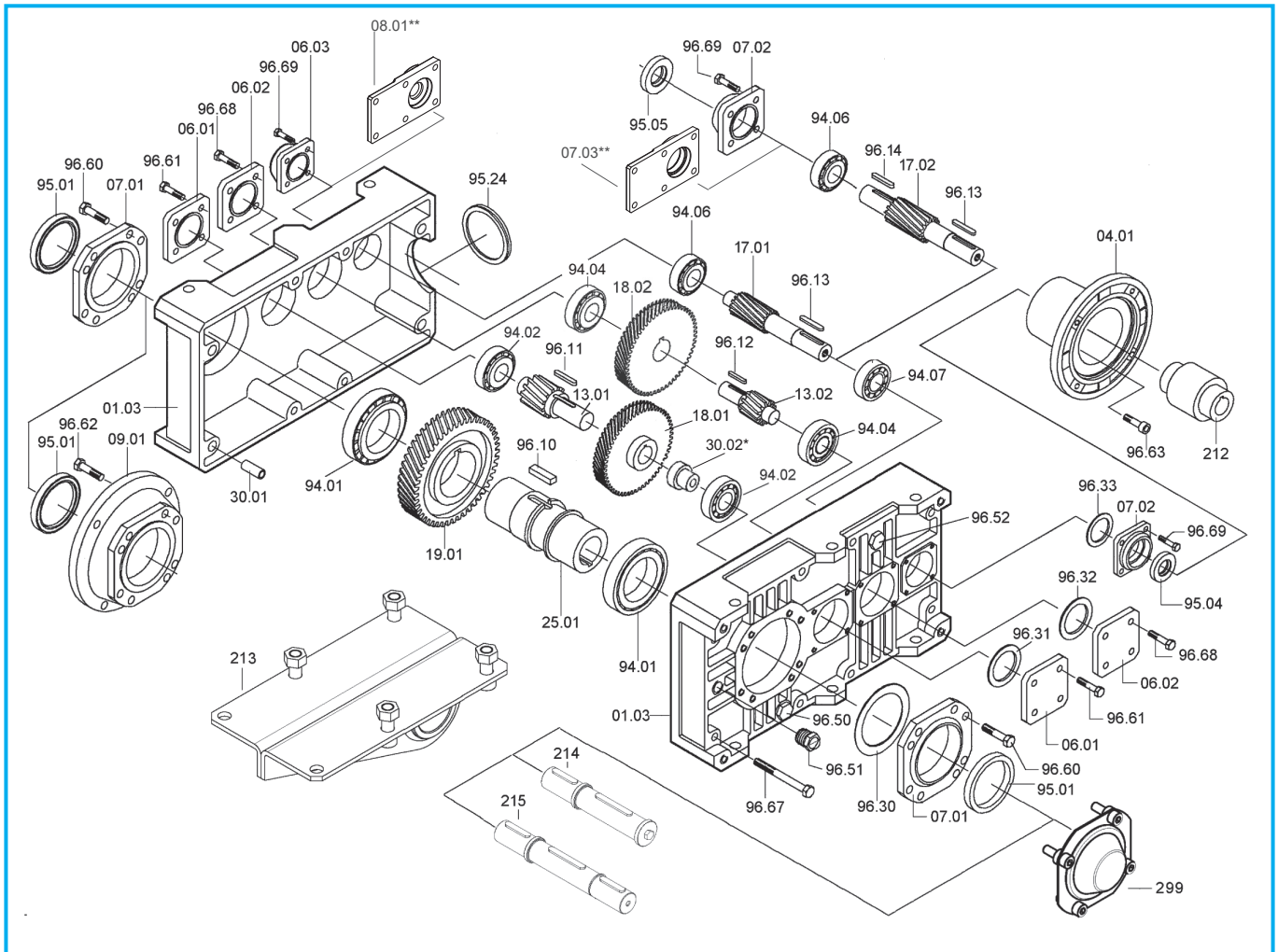

ZA - ZF	Cuscinetti/ Bearings / Lager					Anelli di tenuta / Oilseals / Öldichtungen		
	94.01	94.02	94.04	94.06	94.07	95.01	95.04	95.05
<b>80C</b>	<b>32010</b> 50/80/20	<b>30204</b> 20/47/15.25	<b>30302</b> 15/42/14.25	<b>3202</b> 15/35/15.9	<b>3202</b> 15/35/15.9	50/65/8	15/30/7	15/30/7
<b>100C</b>	<b>32012</b> 60/95/23	<b>30305</b> 25/62/18.25	<b>30204</b> 20/47/15.25	<b>30302</b> 15/42/14.25	<b>32004</b> 20/42/15	60/80/10	20/40/7	15/40/10
<b>125C</b>	<b>32015</b> 75/115/25	<b>32206</b> 30/62/21.25	<b>30305</b> 25/62/18.25	<b>30204</b> 20/47/15.25	<b>32005</b> 25/47/15	75/95/10	25/47/7	20/47/7
<b>160C</b>	<b>32019</b> 95/145/32	<b>32207</b> 35/72/24.25	<b>32206</b> 30/62/21.25	<b>30305</b> 25/62/18.25	<b>30206</b> 30/62/17.25	95/125/12	30/52/7	25/52/7
<b>180C</b>	<b>32024</b> 120/180/38	<b>31309</b> 45/100/27.25	<b>32206</b> 30/62/21.25	<b>30305</b> 25/62/18.25	<b>30206</b> 30/62/17.25	120/160/15	30/52/7	25/52/7
<b>200C</b>	<b>32026</b> 130/200/45	<b>31310</b> 50/110/29.25	<b>30307</b> 35/80/22.75	<b>32206</b> 30/62/21.25	<b>32008</b> 40/68/19	130/160/12	40/56/8	30/56/10

\*Solo per Z180C / Only for Z180C / Nur für Z180C

\*\*Solo per Z80C, 08.01 sostituisce 06.02+06.03; 07.03 sostituisce 07.02+06.03

Only for Z80C 08.01 replace 06.02+06.03; 07.03 replace 07.02+06.03

Nur für Z80C 08.01 ersetzt 06.02+06.03; 07.03 ersetzt 07.02+06.03

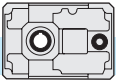

**ZA..B - ZF..B - ZA..C - ZF..C**

Dispositivo antiritorno - *Backstop device* - Rücklaufsperr

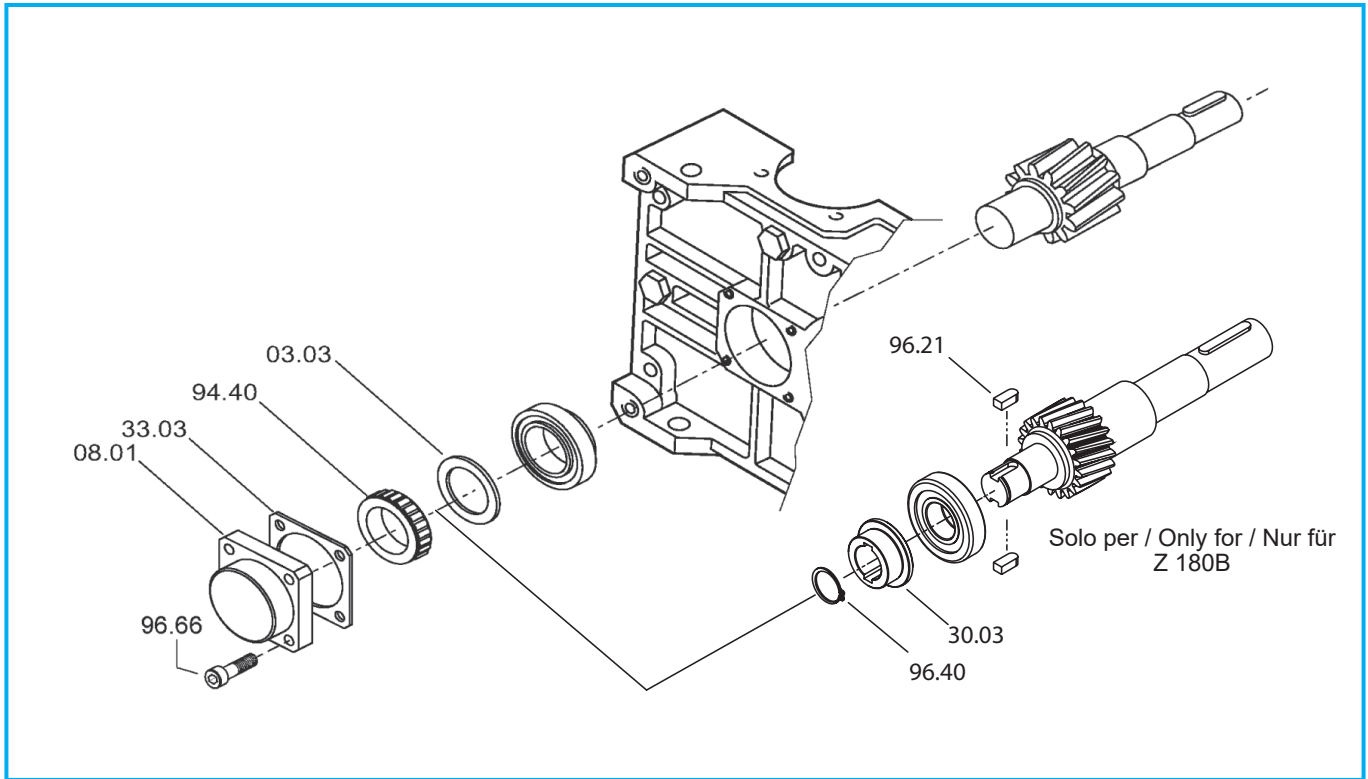

<b>Z...B</b>	Ruota libera / <i>Free wheel</i> / Freilaufgrad 94.40
<b>80</b>	FE 423 Z
<b>100</b>	FE 428 Z
<b>125</b>	BF 50 Z 16
<b>160</b>	BF 70 Z 21
<b>180</b>	FE 8049 Z 19
<b>200</b>	FE 8040 Z 19

<b>Z...C</b>	Ruota libera / <i>Free wheel</i> / Freilaufgrad 94.40
<b>80</b>	FE 423 Z2
<b>100</b>	FE 423 Z
<b>125</b>	FE 428 Z
<b>160</b>	BF 50 Z 16
<b>180</b>	BF 50 Z 16
<b>200</b>	BF 70 Z 21

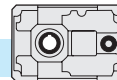

### 3.14 Lista parti di ricambio

### 3.14 Spare parts list

### 3.14 Ersatzteilliste

In fase di ordine delle parti di ricambio, specificare sempre n° particolare (vedi disegno esploso), data (1), n° codice (2) e n° variante (3). (Vedi targhetta).

*When ordering a spare part, the spare part number (see exploded technical drawing), the date (1), the code number (2) and the variant number (3) should always be reported. (See plate)*

Bei der Bestellung von Ersatzteilen sind Ersatzteilnummer (s. Explosionszeichnung), Datum (1), Artikelnummer (2) und Variantennummer (3) anzugeben. (s. Schild)

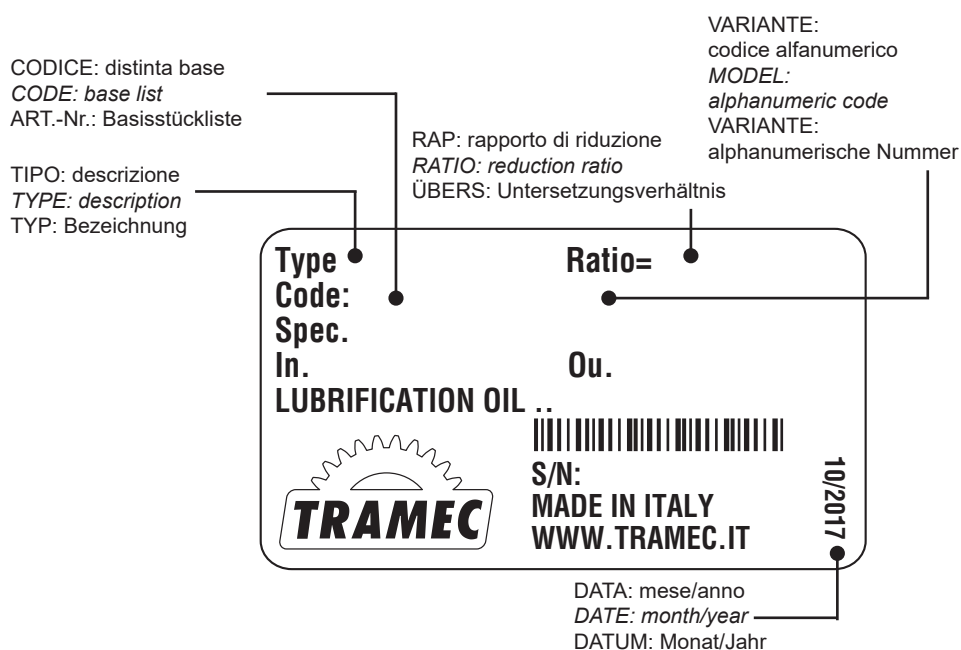

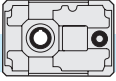

4.0	RIDUTTORI PENDOLARI P	P SHAFT-MOUNTED GEARBOX	AUFSTECKGETRIEBE P	
4.1	Caratteristiche	<i>Characteristics</i>	Merkmale	70
4.2	Designazione	<i>Designation</i>	Bezeichnung	71
4.3	Velocità in entrata	<i>Input speed</i>	Antriebsdrehzahl	71
4.4	Rendimento	<i>Efficiency</i>	Wirkungsgrad	71
4.5	Potenza termica	<i>Thermal power</i>	Thermische Leistung	72
4.6	Dati tecnici	<i>Technical data</i>	Technische Daten	72
4.7	Momenti d'inerzia	<i>Moments of inertia</i>	Trägheitsmoment	73
4.8	Dimensioni	<i>Dimensions</i>	Abmessungen	74
4.9	Accessori	<i>Accessories</i>	Zubehör	75
4.10	Giochi angolari	<i>Angular backlash</i>	Winkelspiel	77
4.11	Lubrificazione	<i>Lubrication</i>	Schmierung	78
4.12	Carichi radiali e assiali	<i>Radial and axial loads</i>	Radial- und Axialbelastungen	79
4.13	Lista parti di ricambio	<i>Spare parts list</i>	Ersatzteilliste	80

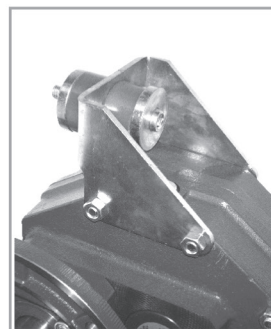
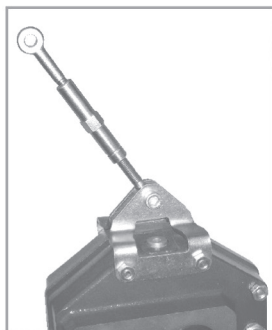
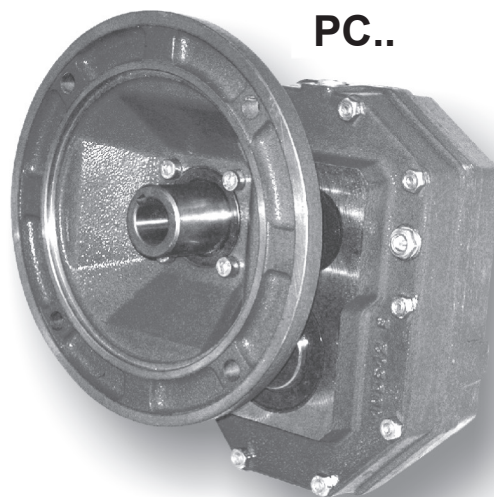
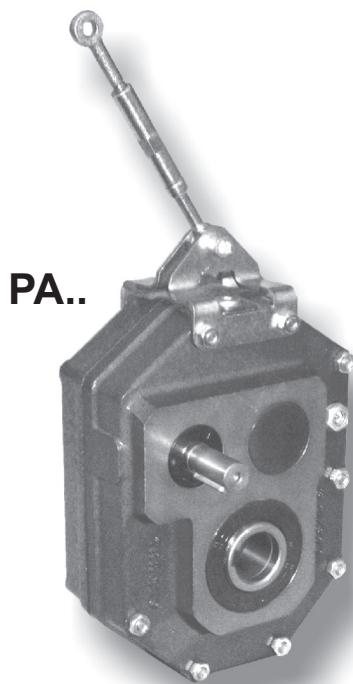





#### 4.1 Caratteristiche

- Costruiti in 6 grandezze ad una riduzione e in 6 grandezze a due riduzioni.
- Sono previsti due tipi di entrata: una con albero entrata sporgente e una con predisposizione attacco motore compatta per l'accoppiamento a motori elettrici flangiati IEC.
- Il corpo riduttore in ghisa meccanica EN GJL 200 UNI EN 1561 abbondantemente nervato all'interno e all'esterno per garantire la rigidità possiede un'unica camera di lubrificazione che garantisce una maggiore dissipazione termica e una migliore lubrificazione di tutti gli organi interni.
- Gli ingranaggi cilindrici, a dentatura elicoidale, sono costruiti in acciaio 16NiCr4, 18NiCrMo5 o 20MnCr5 UNI EN 10084 cementati e temprati, tutti rettificati entro la classe di qualità 6 della DIN 3962.
- L'albero lento cavo di serie in acciaio costruito con fori di vari diametri, la possibilità di montare una flangia uscita sul fianco opposto all'albero entrata, l'ancoraggio tramite un tenditore o un braccio di reazione e la predisposizione per il montaggio del dispositivo antiritorno esaltano le prestazioni di questi riduttori facilitandone l'installazione in molteplici applicazioni.
- Il corpo riduttore, le flange ed i coperchi vengono verniciati esternamente di colore BLU RAL 5010.

#### 4.1 Characteristics

- *Built in 6 sizes with a single reduction stage and in 6 sizes with two reduction stages.*
- *Two input types are available: one with projecting input shaft and one with compact motor coupling for mounting to IEC flanged electric motors.*
- *The gear unit body in engineering cast iron, EN GJL 200 UNI EN 1561 internally and externally ribbed to guarantee rigidity has a single lubrication chamber to guarantee an improved heat dissipation and a better lubrication of all the internal components.*
- *The helical spur gears are built in 16NiCr4, 18NiCrMo5 or 20MnCr5 UNI EN 10084 quench-hardened and case-hardened steel, all ground according to quality 6 DIN 3962.*
- *The standard hollow output shaft made of steel and available with holes of various diameters, the possibility of mounting an output flange on the side opposite the input shaft, anchorage through either a tensioner or a torque arm, the possibility of mounting a backstop device, make these gearboxes highly efficient and facilitate their installation in various applications.*
- *Gearbox housing, flanges and covers are externally painted with BLUE RAL 5010.*

#### 4.1 Merkmale

- Die Getriebe sind in 6 Baugrößen mit 2 Untersetzungsstufen und in 6 Baugrößen zu je 2 Untersetzungsstufen ausgeführt.
- Zwei Antriebsarten (Getriebeeingang) sind lieferbar: Eingangswelle, Motoranbau mit Glocke und Kuplung, Motor Direktanbau.
- Das Getriebegehäuse aus Maschinenguß EN GJL 200 UNI EN 1561 ist sowohl innen als auch außen mit Rippen versehen. Diese gewährleisten die Steifheit. Die einzige Schmierkammer gewährleistet eine höhere Wärmedissipation und eine bessere Schmierung aller inneren Elemente.
- Die Schrägstirnräder bestehen aus ein- und abschreckgehärtetem 16NiCr4, 18NiCrMo5- oder 20MnCr5-Stahl UNI EN 10084, geschliffen innerhalb Qualitätsklasse 6 der Spez. DIN 3962.
- Die serienmäßige Abtriebshohlwelle aus Stahl, die auch mit Bohrungen verschiedener Durchmesser erhältlich ist, die Möglichkeit der Montage eines Abtriebsflansches gegenüber der Abtriebswelle, die Befestigung mittels Spannvorrichtung bzw. Drehmomentstütze, die Auslegung für Montage der Rücklauf Sperre heben die Leistungen dieser Getriebe hervor und erleichtern die Einbau in unterschiedlichen Applikationen.
- Getriebegehäuse, Flansche und Deckel werden in BLAU RAL 5010 lackiert.



#### 4.2 Designazione

#### 4.2 Designation

#### 4.2 Bezeichnung

Macchina Machine Maschine	Tipo entrata Input type Antriebsart	Grandezza Size Größe	Diametro albero lento Output shaft diameter Durchmesser der Abtriebswelle	Rotismo Gearing Räderwerk	Rapporto rid. Ratio Untersetzungsverhältnis	Predisposiz. Motor coupling Motoranschluss	Braccio di reazione Torque arm Drehmomentstütze	Tenditore Tensioner Spannvorrichtung	Esecuzione Execution Ausführung	Posizione di montaggio Mounting position Baulage	Flangia uscita Output flange Abtriebsflansch	Antiritorno Back-stop device Rücklaufsperre
<b>P</b>	<b>A</b>	<b>100</b>	<b>45</b>	<b>B</b>	<b>10/1</b>	<b>P.A.M.</b>	<b>BR</b>	<b>-</b>	<b>O</b>	<b>VA</b>	<b>FLD</b>	<b>CW</b>
Riduttore pendolare Shaft mounted gearbox Aufsteckgetriebe	 A  C	63 80 100 125 160	$D_2$ 25 + 70	 A  B	$i_n =$ 5 + 63	63 + 200	 BR   TE  solo only nur PC...B	 O  solo only nur PA...	P1 P2 P3 P4 VA VB	 FLD  solo only nur PC...B	 AW  CW  solo only nur PA...B	

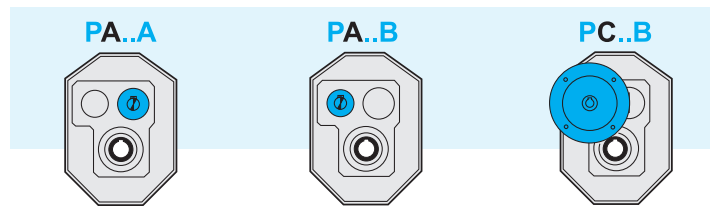

#### 4.3 Velocità in entrata

#### 4.3 Input speed

#### 4.3 Antriebsdrehzahl

Tutte le prestazioni dei riduttori sono calcolate in base ad una velocità in entrata di 1400 min<sup>-1</sup>.

Tutti i riduttori ammettono velocità fino a 3000 min<sup>-1</sup> anche se è consigliabile, dove l'applicazione lo permette, utilizzare valori inferiori a 1400 min<sup>-1</sup>.

Nella tabella sottostante riportiamo i coefficienti correttivi della potenza in entrata P alle varie velocità riferita ad Fs = 1

All calculations of gear unit performance are based on an input speed of 1400 min<sup>-1</sup>. All gear units permit speed up to 3000 min<sup>-1</sup>, nevertheless it is advisable to keep below 1400 min<sup>-1</sup>, depending on application.

The table below reports input power P corrective coefficients at the various speeds, with Fs = 1.

Bei der Berechnung der Getriebeleistungen wurde eine Antriebsdrehzahl von 1400 min<sup>-1</sup> zugrunde gelegt.

Bei allen Getrieben sind Antriebsdrehzahlen bis 3000 min<sup>-1</sup> möglich; es ist jedoch ratsam, die Drehzahlen unter 1400 min<sup>-1</sup> zu halten, wenn die Anwendung es ermöglicht.

In der folgenden Tabelle finden Sie die Korrekturkoeffizienten für die Antriebsleistung P bei den verschiedenen Drehzahlen, bezogen auf Fs = 1.

Tab. 1

n <sub>1</sub> [min <sup>-1</sup> ]	3000	2800	2200	1800	1400	900	700	500
Pc (kW)	P x 1.9	P x 1.8	P x 1.48	P x 1.24	P x 1	P x 0.7	P x 0.56	P x 0.42

#### 4.4 Rendimento

#### 4.4 Efficiency

#### 4.4 Wirkungsgrad

Il valore del rendimento dei riduttori può essere stimato con sufficiente approssimazione in base al numero di riduzioni, trascurando le variazioni non significative attribuibili alle varie grandezze e rapporti.

The efficiency value of the gear units can be estimated sufficiently well on the basis of the number of reduction stages, ignoring non-significant variations which can be attributed to the various sizes and ratios.

Der Wirkungsgrad der Getriebe kann mit ausreichender Annäherung aufgrund der Anzahl der Untersetzungsstufen ermittelt werden; dabei können die unwesentlichen Veränderungen, die auf die verschiedenen Größen und Untersetzungsverhältnisse zurückzuführen sind, außer acht gelassen werden.

η	P...A	P...B
	0.97	0.95



#### 4.5 Potenza termica

#### 4.5 Thermal power

#### 4.5 Thermische Leistung

I valori delle potenze termiche,  $P_{t0}$  (kW), relative alle diverse grandezze di riduttori pendolari sono riportati nella tabella seguente in funzione della velocità di rotazione in entrata del riduttore.

The following table shows the values of thermal power  $P_{t0}$  (kW) for each gearbox size on the basis of rotation speed at gearbox input.

Die folgende Tabelle enthält die Werte  $P_{t0}$  der thermischen Leistung (kW) je nach Getriebegröße und abhängig von Drehzahlen am Getriebeantrieb.

Tab. 2

$n_1$ [min <sup>-1</sup> ]	$P_{t0}$ [kW] - Potenza Termica / Thermal power / Thermische Leistung									
	PA63A	PA63B	PA80A	PA80B	PA100A	PA100B	PA125A	PA125B	PA160A	PA160B
1400	4.6	3.2	8.3	5.9	12.7	8.9	18.5	13.1	29.0	20.5
2800	3.9	2.8	7.0	5.0	10.8	7.6	15.7	11.1	24.7	17.4

#### 4.6 Dati tecnici

#### 4.6 Technical data

#### 4.6 Technische Daten

P	$n_1 = 1400$			PC				PA	
	in	ir	$n_2$ rpm	$T_2$ Nm	P1 kW	FS'	IEC	$T_{2M}$ Nm	P kW
<b>63A</b>	5	5.09	275					190	5.6
	6.3	6.10	230					180	4.5
	8	7.89	177					170	3.3
<b>63B</b>	10	10.35	135	121	1.8	1.9		230	3.4
	12.5	13.18	106	154	1.8	1.6	63	240	2.8
	16	15.79	89	184	1.8	1.4	71	250	2.4
	20	20.33	69	237	1.8	1.1	80	260	2.0
	25	25.88	54	252	1.5	1.1	90 (B5)	270	1.6
	31.5	31.01	45	221	1.1	1.3	80 (B14)	280	1.4
<b>80A</b>	5	5.09	275					380	11.3
	6.3	6.10	230					360	8.9
	8	7.89	177					340	6.5
<b>80B</b>	10	10.20	137	264	4	1.7		460	7.0
	12.5	12.98	108	337	4	1.4	71	480	5.7
	16	15.56	90	403	4	1.2	80	500	5.0
	20	20.36	69	520	4	1.0	90	520	4.0
	25	24.40	57	474	3	1.1	100	540	3.4
	31.5	31.05	45	443	2.2	1.3	112 (B5)	560	2.8
	40	37.21	38	530	2.2	1.0	90 • (B14)	540	2.2
	50	48.12	29	468	1.5	1.1		520	1.7
<b>100A</b>	5	5.09	275					760	22.6
	6.3	6.10	230					720	17.8
	8	7.89	177					680	13.0
<b>100B</b>	10	10.20	137	608	9.2	1.5		920	13.9
	12.5	12.98	108	774	9.2	1.2		960	11.4
	16	15.56	90	927	9.2	1.1		1000	9.9
	20	20.36	69	990	7.5	1.1	80	1040	7.9
	25	24.40	57	870	5.5	1.2	90	1080	6.8
	31.5	31.05	45	1107	5.5	1.0	100	1120	5.6
	40	37.21	38	965	4	1.1	112	1080	4.5
	50	48.12	29	936	3	1.1	132 (B5)	1040	3.3
63	62.23	22	887	2.2	1.1		1000	2.5	

P	$n_1 = 1400$			PC				PA	
	in	ir	$n_2$ rpm	$T_2$ Nm	P1 kW	FS'	IEC	$T_{2M}$ Nm	P kW
<b>125A</b>	5	5.09	275					1520	45.1
	6.3	6.10	230					1440	35.7
	8	7.89	177					1360	26.1
<b>125B</b>	10	10.20	137	1454	22	1.3		1840	27.8
	12.5	12.98	108	1851	22	1.0		1920	22.8
	16	15.56	90	1865	18.5	1.1		2000	19.8
	18*	17.34	81	2072	18.5	1.1		2200	19.5
	20	20.36	69	1979	15	1.1	80	2080	15.8
	25	24.40	57	1739	11	1.2	90	2160	13.7
	31.5	31.05	45	2214	11	1.0	100	2240	11.1
	35*	34.62	40	2087	9.2	1.1	112	2350	10.5
	40	37.21	38	2160	9.2	1.0	160	2160	9.2
	45*	41.48	34	2001	7.5	1.1	180 (B5)	2280	8.5
<b>160A</b>	5	5.09	275					3040	90.2
	10	10.20	137	1983	30	1.9		3680	55.7
	12.5	12.98	108	2524	30	1.5		3840	45.6
	16	15.56	90	3024	30	1.3		4000	39.7
	18*	17.34	81	3360	30	1.3		4350	39.0
	20	20.36	69	3959	30	1.0	100	4160	31.5
	25	24.40	57	3479	22	1.2	112	4320	27.3
<b>160B</b>	31.5	31.05	45	4427	22	1.0	132	4480	22.3
	35*	34.62	40	4196	18.5	1.1	160	4480	20.0
	40	37.21	38	3617	15	1.2	200 (B5)	4320	17.9
	45*	41.48	34	4003	15	1.1		4430	16.5
	50	48.12	29	3430	11	1.2		4160	13.3
	56*	53.64	26	3210	9.2	1.1		3450	9.9
	63	62.23	22	3710	9.2	1.1		4000	9.9

• Flange quadrate / Square flanges / Viereckige Flansche  
\* Rapporti speciali / Special ratios / Sonderverhältnisse

Verifica termica necessaria / Thermal rating needed / Thermische - Prüfung erforderlich





4.7 **Momenti d'inerzia [Kg.cm<sup>2</sup>]**  
(riferiti all'albero veloce in entrata)



4.7 **Moments of inertia [Kg.cm<sup>2</sup>]**  
(referred to input shaft)

4.7 **Trägheitsmoment [Kg.cm<sup>2</sup>]**  
(bez. Antriebswelle)



<b>63A</b>	$i_n$	 PA
	5	1.09
	6.3	0.86
	8	0.62

<b>63B</b>	$i_n$	 PA	 PC				
			IEC B5				
			<b>63</b>	<b>71</b>	<b>80</b>	<b>90</b>	
			10	0.87	1.01	1.38	1.43
			12.5	0.81	0.95	1.33	1.38
			16	0.77	0.92	1.30	1.35
			20	0.40	0.54	0.92	0.97
			25	0.39	0.53	0.91	0.95
			31.5	0.38	0.52	0.90	0.95
			40	0.37	0.51	0.89	0.94



<b>80A</b>	$i_n$	 PA
	5	3.45
	6.3	2.60
	8	1.87

<b>80B</b>	$i_n$	 PA	 PC				
			IEC B5				
			<b>71</b>	<b>80</b>	<b>90</b>	<b>100-112</b>	
			10	3.40	3.57	3.95	4.79
			12.5	3.23	3.40	3.77	4.61
			16	3.11	3.28	3.66	4.49
			20	1.68	1.85	2.23	3.07
			25	1.45	1.62	1.99	2.83
			31.5	1.42	1.59	1.96	2.80
			40	1.39	1.56	1.94	2.78



<b>100A</b>	$i_n$	 PA
	5	10.09
	6.3	7.40
	8	5.26

<b>100B</b>	$i_n$	 PA	 PC				
			IEC B5				
			<b>80</b>	<b>90</b>	<b>100-112</b>	<b>132</b>	
			10	11.01	10.88	11.83	14.97
			12.5	10.15	10.02	10.98	14.12
			16	9.75	9.62	10.57	13.71
			20	5.08	4.95	5.90	9.04
			25	4.27	4.14	5.10	8.24
			31.5	4.12	3.99	4.95	8.09
			40	4.05	3.92	4.88	8.02

<b>125A</b>	$i_n$	 PA
	5	28.98
	6.3	22.22
	8	15.91

<b>125B</b>	$i_n$	 PA	 PC						
			IEC B5						
			<b>80</b>	<b>90</b>	<b>100-112</b>	<b>132</b>	<b>160</b>	<b>180</b>	
			10	29.78	29.65	29.79	32.99	37.41	40.43
			12.5	26.98	26.85	26.98	30.18	34.61	37.63
			16	25.93	25.80	25.94	29.14	33.56	36.58
			18*	25.26	25.13	25.27	28.47	32.89	35.91
			20	12.52	12.39	12.53	15.73	20.15	23.17
			25	10.19	10.06	10.20	13.40	17.83	20.84
			31.5	9.70	9.57	9.71	12.91	17.34	20.35
			35*	11.39	11.26	11.40	14.60	19.02	22.04
			40	9.52	9.39	9.53	12.73	17.15	20.17
			45*	9.40	9.27	9.41	12.61	17.04	20.05
			50	9.37	9.24	9.38	12.58	17.01	20.02

<b>160A</b>	$i_n$	 PA
	5	93.17

<b>160B</b>	$i_n$	 PA	 PC					
			IEC B5					
			<b>110-112</b>	<b>132</b>	<b>160</b>	<b>180</b>	<b>200</b>	
			10	91.32	97.00	96.00	98.91	109.30
			12.5	81.74	87.42	86.42	89.33	99.72
			16	79.04	84.72	83.72	86.63	97.02
			18*	77.56	83.24	82.24	85.15	95.54
			20	37.42	43.10	42.10	45.01	55.40
			25	30.18	35.86	34.86	37.77	48.16
			31.5	28.51	34.19	33.19	36.10	46.49
			35*	33.96	39.65	38.65	41.56	51.94
			40	28.03	33.72	32.72	35.63	46.01
			45*	27.78	33.46	32.46	35.37	45.76
			50	27.50	33.18	32.18	35.09	45.48



4.8 Dimensioni

4.8 Dimensions

4.8 Abmessungen

		PA...A - PA...B - PC...B														
		63			80			100			125			160		
<b>A</b>		194			266			331			405			510		
<b>B</b>		97			120			143			164			196		
<b>C2</b>		101			130			155			180			220		
<b>D2<sub>H7</sub></b>		25	28	30	30	35	38	40	45	50	55	60	65	70		
<b>E</b>		140			196			242			293			367		
<b>G</b>		68			82			100			118			146		
<b>H</b>		70			98			121			146.5			183.5		
<b>O</b>		61.5			79.5			99.5			123.5			157		
<b>P</b>		30.3			43.9			59.6			72.4			85.1		
<b>R</b>		17.7			20.1			22.4			29.6			41.9		

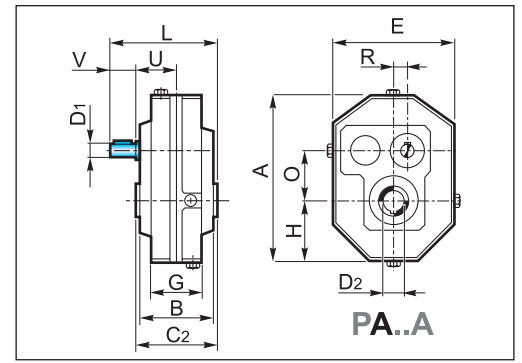

		PA...A				
<b>D1<sub>h6</sub></b>		19	24	28	38	48
<b>V</b>		40	50	60	80	80
<b>L</b>		157	194	229	281	342
<b>U</b>		66	79	91	111	152
<b>kg</b>		10	16	28	52	108

		PA...B				
<b>D1<sub>h6</sub></b>		14	19	24	28	38
<b>V</b>		30	40	50	60	80
<b>L</b>		138	171	206	241	301.5
<b>U</b>		51.5	66	78.5	91	111.5
<b>kg</b>		12	18	34	58	120

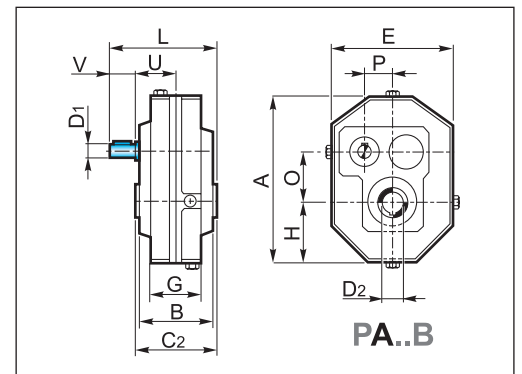

		PC...B							
		63				80			
<b>IEC</b>		63 B5	71 B5	80/90 B5	80 B14	71 B5	80/90 B5	*90 B14	100/112 B5
<b>Y</b>		140	160	200	120	160	200	120 / R 73	250
<b>L1</b>		141	148	168	168	173	193	193	203
<b>U1</b>		90.5	97.5	117.5	117.5	108	128	128	138

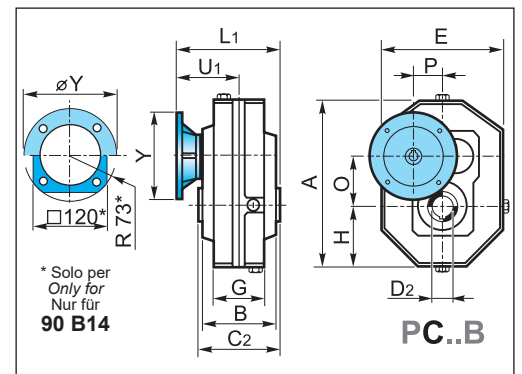

\* Flange quadrata / Square flanges / Viereckige Flansche

		PC...B										
		100			125				160			
<b>IEC</b>		80/90 B5	100/112 B5	132 B5	80/90 B5	100/112 B5	132 B5	160/180 B5	100/112 B5	132 B5	160/180 B5	200 B5
<b>Y</b>		200	250	300	200	250	300	350	250	300	350	400
<b>L1</b>		221	231	253	244	254	276	306	298	318	348	348
<b>U1</b>		143.5	153.5	175.5	154	164	186	216	188	208	238	238

		PA...A						
		63		80		100	125	160
<b>D1<sub>h6</sub></b>		19		24		28	38	48
<b>d1</b>		M8		M8		M8	M10	M12
<b>M1</b>		21.5		27		31	41	51.5
<b>N1</b>		6		8		8	10	14

		PA...B				
<b>D1<sub>h6</sub></b>		14	19	24	28	38
<b>d1</b>		M6	M8	M8	M8	M10
<b>M1</b>		16	21.5	27	31	41
<b>N1</b>		5	6	8	8	10

		PA...A - PA...B - PC...B														
		63			80			100			125			160		
<b>C2</b>		101			130			155			180			220		
<b>D2<sub>H7</sub></b>		25	28	30	30	35	38	40	45	50	55	60	65	70		
<b>M2</b>		28.3	31.3	33.3	33.3	38.3	41.3	43.3	48.8	54.3	59.3	64.4	69.4	79.4		
<b>N2</b>		8	8	8	8	10	10	12	14	14	16	18	18	20		
<b>Z2</b>		7.3	7.3	7.3	8.5	8.5	8.5	10.8	10.8	12	12	15.5	15.5	15.5		

Albero entrata  
Input shaft  
Antriebswelle

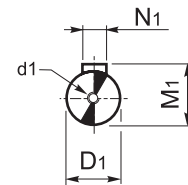

Albero uscita cavo  
Hollow output shaft  
Abtriebshohlwelle

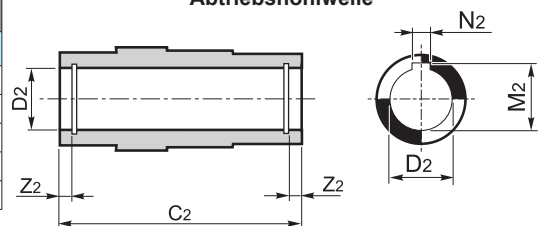



4.9 Accessori

4.9 Accessories

4.9 Zubehör

**Braccio di reazione**  
*Torque arm*  
**Drehmomentstütze**

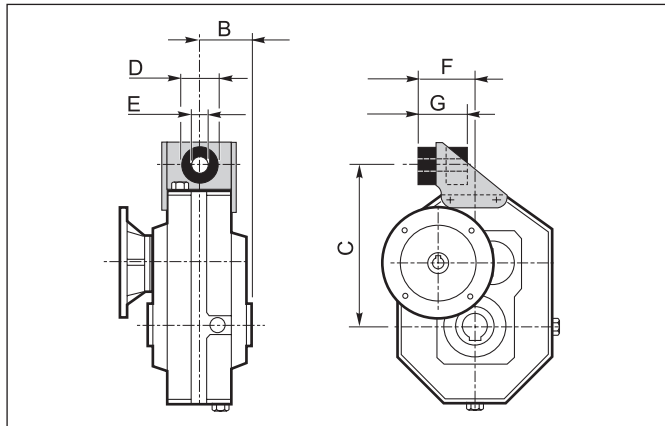

	PC...B				
	63	80	100	125	160
<b>B</b>	50.5	65	77.5	90	110
<b>C</b>	150	200	250	308	385
<b>D</b>	40	40	60	60	80
<b>E</b>	12.5	12.5	21	21	25
<b>F</b>	64.5	78	101	116	144
<b>G</b>	53	55	85	86	112

**Tenditore**  
*Tensioner*  
**Spannvorrichtung**

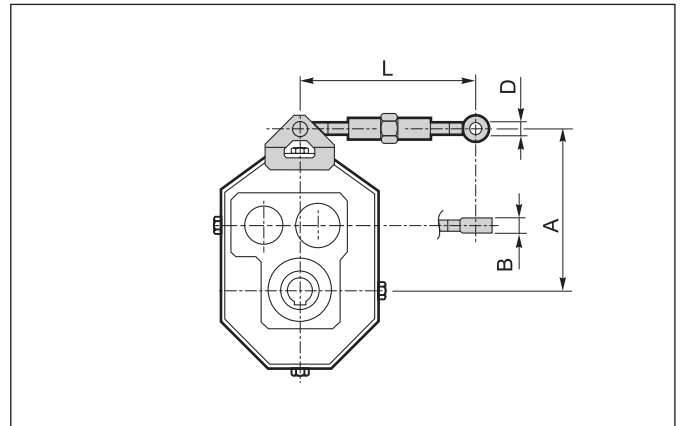

	PA..A - PA..B				
	63	80	100	125	160
<b>A</b>	151	199	254.5	314	393
<b>B</b>	8	10	12	14	16
<b>D</b>	8	10	12	14	16
<b>Lmax.</b>	264	264	266	270	272
<b>Lmin.</b>	206	204	218	214	222

**Albero lento**

**Output shaft**

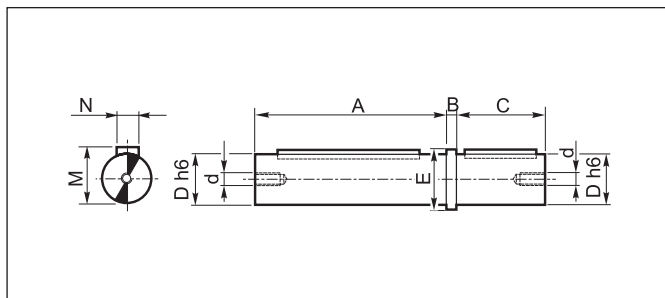

**Abtriebswelle**

	PA...A - PA...B - PC...B				
	63	80	100	125	160
<b>A</b>	100	129	154	179	219
<b>B</b>	5	6	8	10	12
<b>C</b>	50	60	80	100	125
<b>D<sub>h6</sub></b>	25	35	45	55	70
<b>d</b>	M8	M8	M10	M10	M12
<b>E</b>	32	43	53	65	80
<b>M</b>	28	38	48.5	59	74.5
<b>N</b>	8	10	14	16	20

Materiale albero lento: **C45** - Output shaft material: **C45** - Material der Abtriebswelle: **C45**

**Kit fissaggio e smontaggio**  
**riduttori con albero lento cavo**

**Kit for the mounting and dismounting**  
**of the gearboxes with hollow output** **Kit für Montage und Ausbau der**  
**Getriebe mit Abtriebshohlwelle shaft**

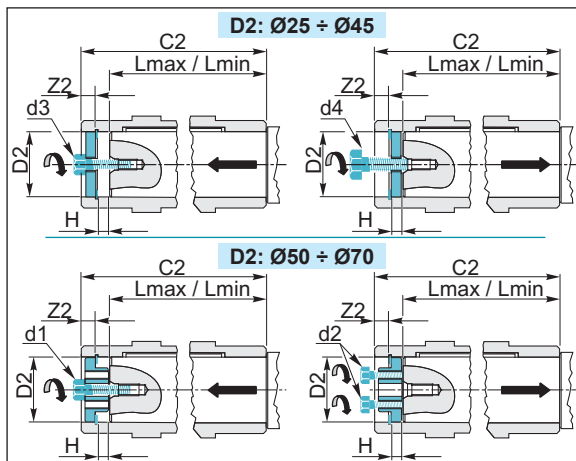

	P												
	63		80		100		125		160				
<b>C2</b>	101		130		155		180		220				
<b>D2</b>	25	28	30	30	35	38	40	45	50	55	60	65	70
<b>H</b>	7			7	6.5		8		9		12	11.5	12
<b>d1</b>	—		—		—		M10		M12		—		—
<b>d2</b>	—		—		—		M8		M10		—		—
<b>d3</b>	M8		M8		M8		—		—		—		—
<b>d4</b>	M12		M12		M12		—		—		—		—
<b>Z2</b>	7.2		8.7	8.4	10.7		11.9		15.9	15.4			
<b>Lmax</b>	84		112		133		156		189		—		—
<b>Lmin</b>	79		107		128		149		182		—		—



**Predisposizione per flangia uscita**

**Coupling for output flange**

**Auslegung für Abtriebsflansch**

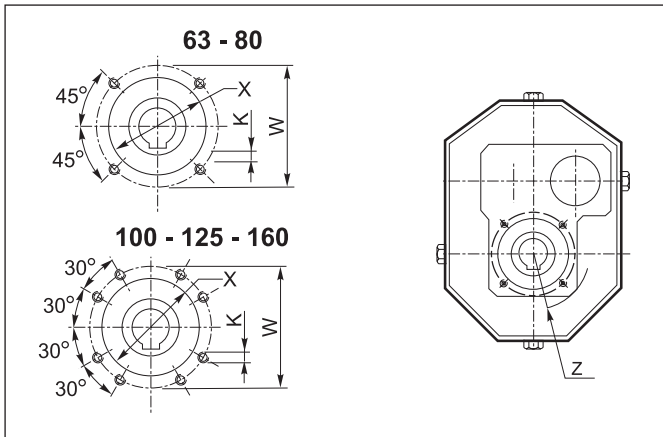

	PA...A - PA...B - PC...B				
	63	80	100	125	160
<b>K</b>	M6 x 12	M10 x 12	M8 x 12	M10 x 15	M12 x 20
<b>W</b>	80	105	122	145	186
<b>Z</b>	50	64.5	72.5	90	110
<b>X</b>	62	80	100	120	136

**Flangia uscita**

**Output flange**

**Abtriebsflansch**

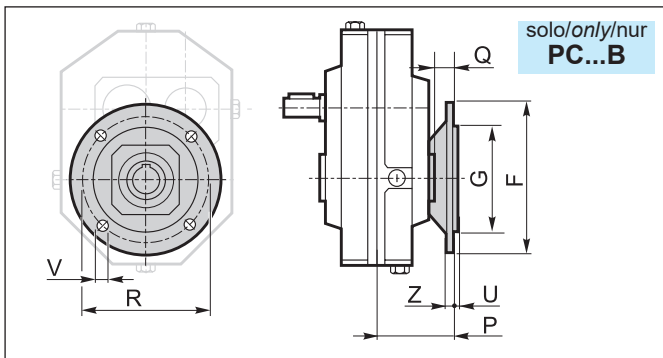

	PC...B				
	63	80	100	125	160
<b>F</b>	160	200	250	300	350
<b>G f7</b>	110	130	180	230	250
<b>R</b>	130	165	215	265	300
<b>P</b>	86.5	98	110	135	177.5
<b>Q</b>	36	33	32.5	45	67.5
<b>U</b>	3	4	4	4	5
<b>V</b>	9	12	14	14	19
<b>Z</b>	10	10	12	15	16

**Dispositivo antiritorno**

**Backstop device**

**Rücklaufsperre**

Il riduttore pendolare presenta valori di rendimento statico (e dinamico) molto elevati: per questo motivo non è garantita spontaneamente l'irreversibilità statica. L'irreversibilità statica si realizza quando, a riduttore fermo, l'applicazione di un carico all'albero lento non pone in rotazione l'asse entrata. Pertanto, per garantire l'irreversibilità del moto, a riduttore fermo, occorre predisporre il riduttore stesso con un opportuno dispositivo antiritorno, fornibile a richiesta solo nel caso di riduttore a 2 stadi di riduzione con entrata alberata (PA..B escluso PA 63B). Tale dispositivo permette la rotazione dell'albero lento solo nel senso desiderato, da specificare all'atto dell'ordine.

*Shaft-mounted gearboxes feature quite high values of static (and dynamic) efficiency: for this reason spontaneous static irreversibility is not guaranteed. Static irreversibility, with motionless gearbox, occurs when the application of a load on the output shaft does not cause rotation of the input axis. In order to guarantee motion irreversibility, with motionless gearbox, it is necessary to fit a backstop device, which is available on request only for gearbox with 2 reduction stages input shaft version (PA..B excluded).*  
*The backstop device enables rotation of the output shaft only in the required direction, which is to be specified when ordering.*

Aufsteckgetriebe haben sehr hohen statischen (und dynamischen) Wirkungsgrad: deshalb wird keine spontane statische Irreversibilität garantiert. Statische Irreversibilität bei stillstehenden Getriebe hat man, wenn die Applikation mit einer Last auf die Abtriebswelle, keine Drehung der Antriebswelle verursacht. Um Irreversibilität der Bewegung bei stillstehendem Getriebe zu sichern, sollte eine Rücklaufsperre montiert werden. Die Rücklaufsperre wird auf Wunsch nur für Getriebe mit 2 Untersetzungsstufen und Welle am Antrieb (PA..B mit Ausnahme von PA 63B) geliefert. Die Rücklaufsperre ermöglicht, dass die Abtriebswelle nur in der gewünschten Richtung dreht (gewünschte Richtung beim Bestellen angeben).

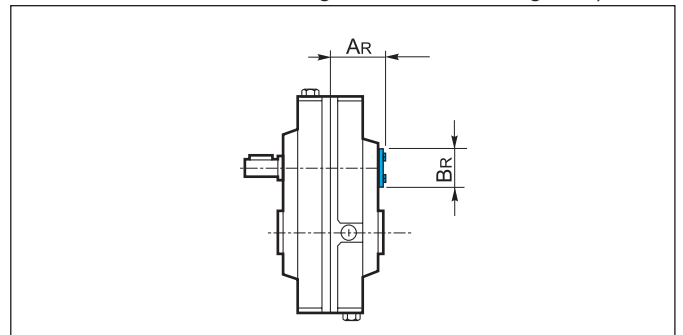
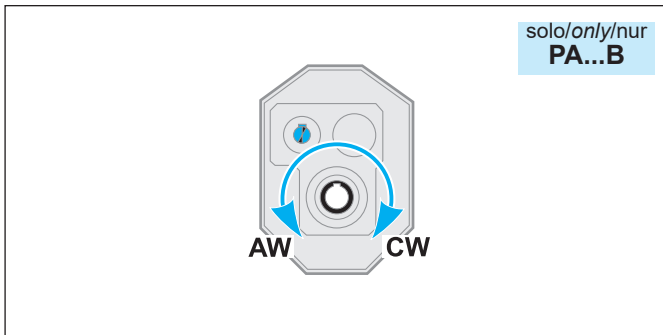

**CW** Rotazione oraria  
 Clockwise rotation  
 Im Uhrzeigersinn

**AW** Rotazione antioraria  
 Anti-clockwise rotation  
 Gegen den Uhrzeigersinn

	PA 80B	PA 100B	PA 125B	PA 160B
<b>AR</b>	70	83.5	95	112
<b>BR</b>	60	65	85	95



Nel caso in cui sia presente il dispositivo antiritorno è necessario l'utilizzo di olio lubrificante sintetico, classe di viscosità ISO 150.

*The utilization of synthetic oil, viscosity class ISO 150, is necessary for the gearboxes equipped with back stop device.*

Die Getriebe mit einer Rücklaufsperrung müssen mit synthetischem Öl (Viskosität ISO150) betrieben werden.

Nella tabella seguente (tab 3) sono indicati i valori dei momenti torcenti nominali massimi ( $T_{2Mmax}$ ), riferiti all'albero uscita, garantiti dal dispositivo di antiritorno, per ogni rapporto di riduzione e per ogni grandezza di riduttore. Se, in corrispondenza dell'albero lento, viene applicata una coppia maggiore di quella indicata, l'irreversibilità del moto non è più garantita. Questi valori di coppia non sono da confondere con quelli riportati nella tabella riguardante i dati tecnici dei riduttori.

*The following table (tab. 3) shows the max. rated torques ( $T_{2Mmax}$ ) at gearbox output guaranteed by the backstop device, for each ratio and each gearbox size. If a higher torque is applied at gearbox output, motion irreversibility is no longer guaranteed.*

In der folgenden Tabelle (Tab. 3) werden die max. Nenndrehmomente am Abtrieb angegeben ( $T_{2Mmax}$ ), die die Rücklaufsperrung je nach Untersetzungsverhältnis und Getriebegröße garantieren. Falls am Abtrieb ein höheres Drehmoment eingesetzt wird, dann ist die Irreversibilität der Bewegung nicht mehr garantiert.

Infatti, si noti come in tabella siano stati messi in evidenza i valori di coppia garantiti (in uscita) dal dispositivo antiretro che risultano essere minori dei massimi valori di coppia motrice trasmissibili, con fattore di servizio  $F_s = 1$ , dal riduttore.

*These torque values are not to be confused with the values reported in the gearbox specifications tables.*

Diese Drehmomente sind nicht mit den Werten zu verwechseln, die in der Tabelle der technischen Daten der Getriebe angegeben werden.

*Please note that the torque values guaranteed (at output) by the backstop device are lower than the max. driving torque values transmissible by the gearbox, with service factor  $F_s = 1$ .*

Die von der Rücklaufsperrung (am Abtrieb) garantierten Drehmomente sind niedriger als die vom Getriebe übersetzbaren max. Drehmomente, unter Berücksichtigung eines Betriebsfaktors  $F_s = 1$ .

Vedere paragrafo 1.5 per la verifica del dispositivo antiritorno.

*To check the back stop device pls see paragraph 1.5.*

Für die Überprüfung der Rücklaufsperrung siehe Abschnitt 1.5.

Tab. 3

i	$T_{2Mmax}$ [Nm]												
	10	12.5	16	18	20	25	31.5	35	40	45	50	56	63
PA 80B	544	692	830	—	1086	1301	1656	—	1985	—	2566	—	3319
PA 100B	850	1082	1297	—	1697	2033	2588	—	3101	—	4010	—	5186
PA 125B	1870	2380	2853	3179	3733	4473	5693	6347	6822	7605	8822	9836	11409
PA 160B	3944	5019	6017	6706	7873	9435	12006	13389	14388	16042	18606	20747	24062

#### 4.10 Giochi angolari

Bloccando l'albero di entrata, il gioco viene misurato sull'albero uscita ruotandolo nelle due direzioni ad applicando la coppia strettamente necessaria a creare il contatto tra i denti degli ingranaggi, al massimo pari al 2% della coppia massima garantita dal riduttore.

Nella tabella seguente sono riportati i valori indicativi del gioco angolare (in minuti di angolo).

#### 4.10 Angular backlash

*After having blocked the input shaft, the angular backlash can be measured on the output shaft by rotating it in both directions and applying the torque which is strictly necessary to create a contact between the teeth of the gears. The applied torque should be at most 2% of the max. torque guaranteed by the gearbox.*

*The following table reports the approximate values of the angular backlash (in minutes of arc).*

#### 4.10 Winkelspiel

Nachdem die Antriebswelle blockiert worden ist, kann das Winkelspiel an der Abtriebswelle gemessen werden. Dabei soll die Abtriebswelle in den beiden Richtungen gedreht und ein Drehmoment ausgeübt werden, das zur Entstehen eines Kontaktes zwischen den Zähnen genügt. Das ausgeübte Drehmoment soll höchstens 2% des max. vom Getriebe garantierten Drehmoment sein.

Die folgende Tabelle weist die Näherungswerte des Winkelspiels (in Bogenminuten).

Gioco angolare / Backlash / Winkelspiel (1')			
P.A	10-16	P.B	16-20





#### 4.11 Lubrificazione

I riduttori pendolari sono forniti predisposti per lubrificazione a olio e muniti dei tappi di carico, livello e scarico olio.  
Si raccomanda di precisare sempre la posizione di montaggio desiderata in fase di ordine.

#### Posizione di montaggio e quantità di lubrificante (litri)

I quantitativi di olio riportati nelle varie tabelle sono indicativi e riferiti alle posizioni di lavoro indicate e considerando le condizioni di funzionamento a temperatura ambiente e velocità in ingresso di 1400 min<sup>-1</sup>. Per condizioni di lavoro diverse da quelle sopra riportate contattare il servizio tecnico.

#### 4.11 Lubrication

Shaft-mounted gearboxes require oil lubrication and are equipped with filler, level and drain plugs.  
The mounting position should always be specified when ordering the gearbox.

#### Mounting positions and lubricant quantity (litres)

The oil quantities stated in the tables are approximate values and refer to the indicated working positions, considering operating conditions at ambient temperature and an input speed of 1400 min<sup>-1</sup>. Should the operating conditions be different, please contact the technical service.

#### 4.11 Schmierung

Die Aufsteckgetriebe sind für die Ölschmierung mit Einfüll-, Ölstand- und Ablassstopfen versehen.  
Bei der Bestellung ist immer die gewünschte Montageposition anzugeben.

#### Montageposition und Ölmenge (Liter)

Die in den Tabellen angegebenen Daten sind Richtwerte. Die Ölmenge beziehen sich auf die angegebene Betriebsposition. Dabei werden Betrieb bei Umgebungstemperatur und Antriebsdrehzahl von 1400 min<sup>-1</sup> berücksichtigt. Falls die Betriebsbedingungen anders sind, muß mit dem technischen Büro Rücksprache gehalten werden.

#### PA - PC

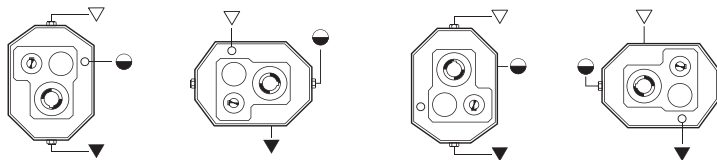

#### solo/only/nur PC

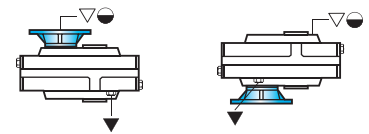

P	P1	P2	P3	P4	VA	VB
63A - 63B	0.55	0.45	0.55	0.45	0.7	0.7
80A - 80B	1.2	0.9	1.1	0.9	1.4	1.4
100A - 100B	2.2	1.8	2.2	1.8	2.8	2.8
125A - 125B	4.4	3.6	4.4	3.6	5.6	5.6
160A - 160B	8.8	7.2	8.8	7.2	11.2	11.2

#### Posizione morsettiera

#### Terminal board position

#### Lage des Klemmenkastens

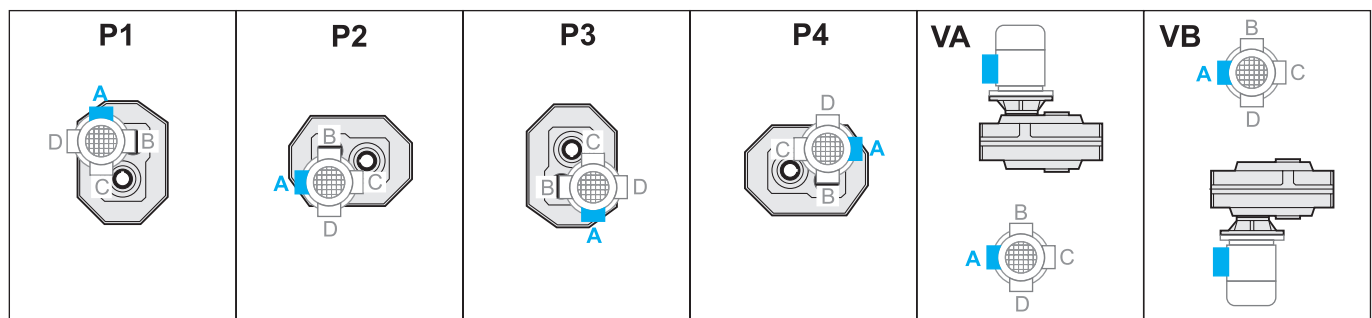



#### 4.12 Carichi radiali e assiali (N)

Le trasmissioni effettuate tramite pignoni per catena, ruote dentate o pulegge generano delle forze radiali ( $F_R$ ) sugli alberi dei riduttori. L'entità di tali forze può essere calcolata con la formula:

#### 4.12 Radial and axial loads (N)

Transmissions implemented by means of chain pinions, wheels or pulleys generate radial forces ( $F_R$ ) on the gear unit shafts. The entity of these forces may be calculated using the following formula:

#### 4.12 Radial- und Axialbelastungen (N)

Antriebe mit Kettenritzel, Zahnrädern oder Riemscheiben erzeugen radiale Kräfte ( $F_R$ ) an den Wellen der Untersetzungsgetriebe. Die Größe dieser Kraft kann nach folgender Formel berechnet werden:

$$F_R = \frac{K_R \cdot T}{d} \text{ [N]}$$

dove:

T = Momento torcente [Nm]

d = Diametro pignone o puleggia [mm]

$K_R$  = 2000 per pignone per catena

= 2500 per ruote dentate

= 3000 per puleggia con cinghie a V

where:

T = torque [Nm]

d = pinion or pulley diameter [mm]

$K_R$  = 2000 for chain pinion

= 2500 for wheel

= 3000 for V-belt pulley

dabei ist:

T = Drehmoment [Nm]

d = Kettenritzel- bzw. Riemscheiben durchmesser [mm]

$K_R$  = 2000 bei Kettenritzel

= 2500 bei Zahnrad

= 3000 bei Riemscheibe mit Keilriemen

I valori dei carichi radiali e assiali generati dall'applicazione debbono essere sempre minori o uguali a quelli ammissibili indicati nelle tabelle.

The values of the radial and axial loads generated by the application must always be lower than or equal to the admissible values reported in the tables.

Die Werte der Radial- und Axialbelastungen, die durch die Anwendung hervorgerufen werden, dürfen nicht über den in den Tabellen angegebenen zulässigen Werten liegen.

$$F_R \geq Fr_{1-2}$$

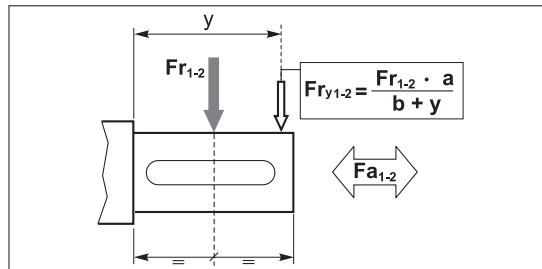

Se il carico radiale sull'albero non è applicato a metà della sporgenza dell'albero, il valore del carico ammissibile deve essere valutato utilizzando la formula che si riferisce ad  $F_{ry1-2}$ , in cui i valori di a, b e  $F_{r1-2}$  sono riportati nelle tabelle relative ai carichi radiali.

Should the radial load affect the shaft not at the half-way point of its projection but at a different point, the value of the admissible load has to be calculated using the  $F_{ry1-2}$  formula: a, b and  $F_{r1-2}$  values are reported in the radial load tables.

Falls die Radialbelastungen bei der halben Länge der herausragenden Welle wirken, soll die zulässige Belastung mit der Formel bezüglich  $F_{ry1-2}$  kalkuliert werden: a, b und  $F_{r1-2}$  Werte sind aus der Tabelle der Radialbelastungen zu entnehmen.

	P 63B		P 63A P 80B		P 80A P 100B		P 100A P 125B		P 125A P 160B	
<b>ALBERO ENTRATA / INPUT SHAFT / ANTRIEBSWELLE (<math>n_1 = 1400 \text{ min}^{-1}</math>)</b>										
$i_n$	a=107	b=92	a=118.25	b=98.25	a=141.25	b=116.25	a=165.25	b=135.25	a=203.25	b=163.25
	$F_{r1}$	$F_{a1}$	$F_{r1}$	$F_{a1}$	$F_{r1}$	$F_{a1}$	$F_{r1}$	$F_{a1}$	$F_{r1}$	$F_{a1}$
Tutti All/ Alle	315	60	400	80	630	125	1000	200	1600	320
	P 63B		P 80B		P 100B		P 125B		P 160B	
<b>ALBERO USCITA / OUTPUT SHAFT / ABTRIEBSWELLE (<math>n_1 = 1400 \text{ min}^{-1}</math>)</b>										
$i_n$	a=111	b=81	a=139	b=103	a=170.5	b=122.5	a=204.5	b=144.5	a=251.5	b=177
	$F_{r2}$	$F_{a2}$	$F_{r2}$	$F_{a2}$	$F_{r2}$	$F_{a2}$	$F_{r2}$	$F_{a2}$	$F_{r2}$	$F_{a2}$
10	1140	230	2800	560	3250	650	5150	1030	9580	1910
12.5	1340	270	3100	620	3700	740	5830	1160	10680	2130
16	1480	295	3450	690	4220	840	6590	1310	11925	2385
18*	—	—	—	—	—	—	7010	1390	12610	2520
20	1910	380	3820	765	4780	950	7430	1480	13290	2660
25	1930	385	4200	840	5350	1070	8280	1650	14680	2930
31.5	2180	435	4630	925	6160	1230	9245	1850	16250	3250
35*	—	—	—	—	—	—	9770	1950	17100	3420
40	2400	480	5100	1020	6700	1340	10300	2060	17970	3590
45*	—	—	—	—	—	—	10840	2160	18840	3760
50	—	—	5580	1115	7430	1480	11380	2270	19720	3940
56*	—	—	—	—	—	—	11840	2360	20480	4090
63	—	—	6000	1200	8060	1600	12310	2460	21250	4250

\* Rapporti speciali / Special ratios / Sonderverhältnisse



**PA..A**

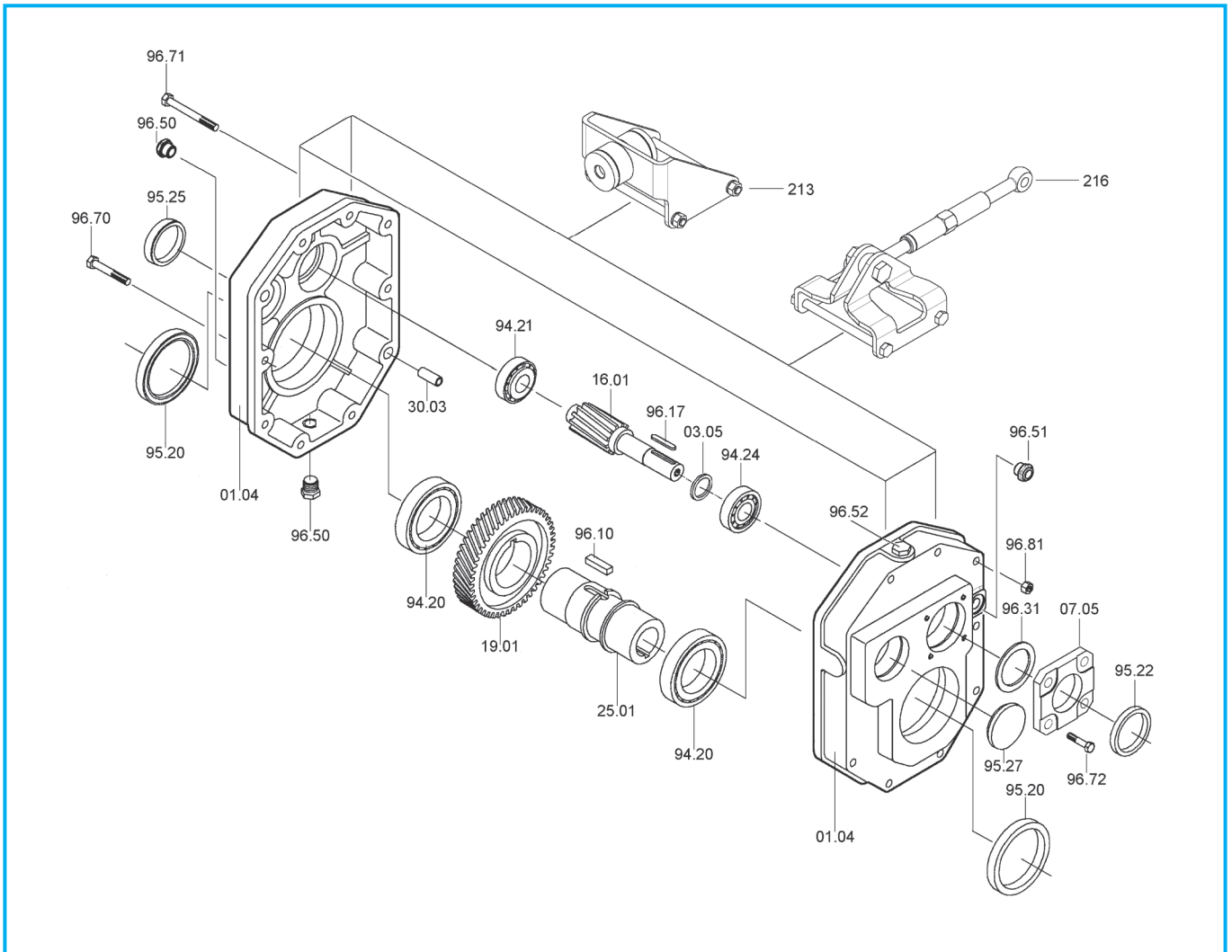

PA	Cuscinetti/ Bearings / Lager			Anelli di tenuta / Oilseals / Öldichtungen	
	94.20	94.21	94.24	95.20	95.22
<b>63A</b>	<b>6008</b> 40/68/15	<b>30302</b> 15/42/14.25	<b>32004</b> 20/42/15	40/62/7	<b>20/35/7</b>
<b>80A</b>	<b>6210</b> 50/90/20	<b>30304</b> 20/52/16.25	<b>30205</b> 25/52/16.25	50/80/10	<b>25/40/7</b>
<b>100A</b>	<b>6212</b> 60/110/22	<b>30305</b> 25/62/18.25	<b>30206</b> 30/62/17.25	60/100/13	<b>30/52/7</b>
<b>125A</b>	<b>6215</b> 75/130/25	<b>30306</b> 30/72/20.75	<b>30208</b> 40/80/19.75	75/120/12	<b>40/68/10</b>
<b>160A</b>	<b>6219</b> 95/170/32	<b>32208</b> 40/80/24.75	<b>30210</b> 50/90/21.75	95/136/13	<b>50/80/8</b>



## PA..B - PC..B

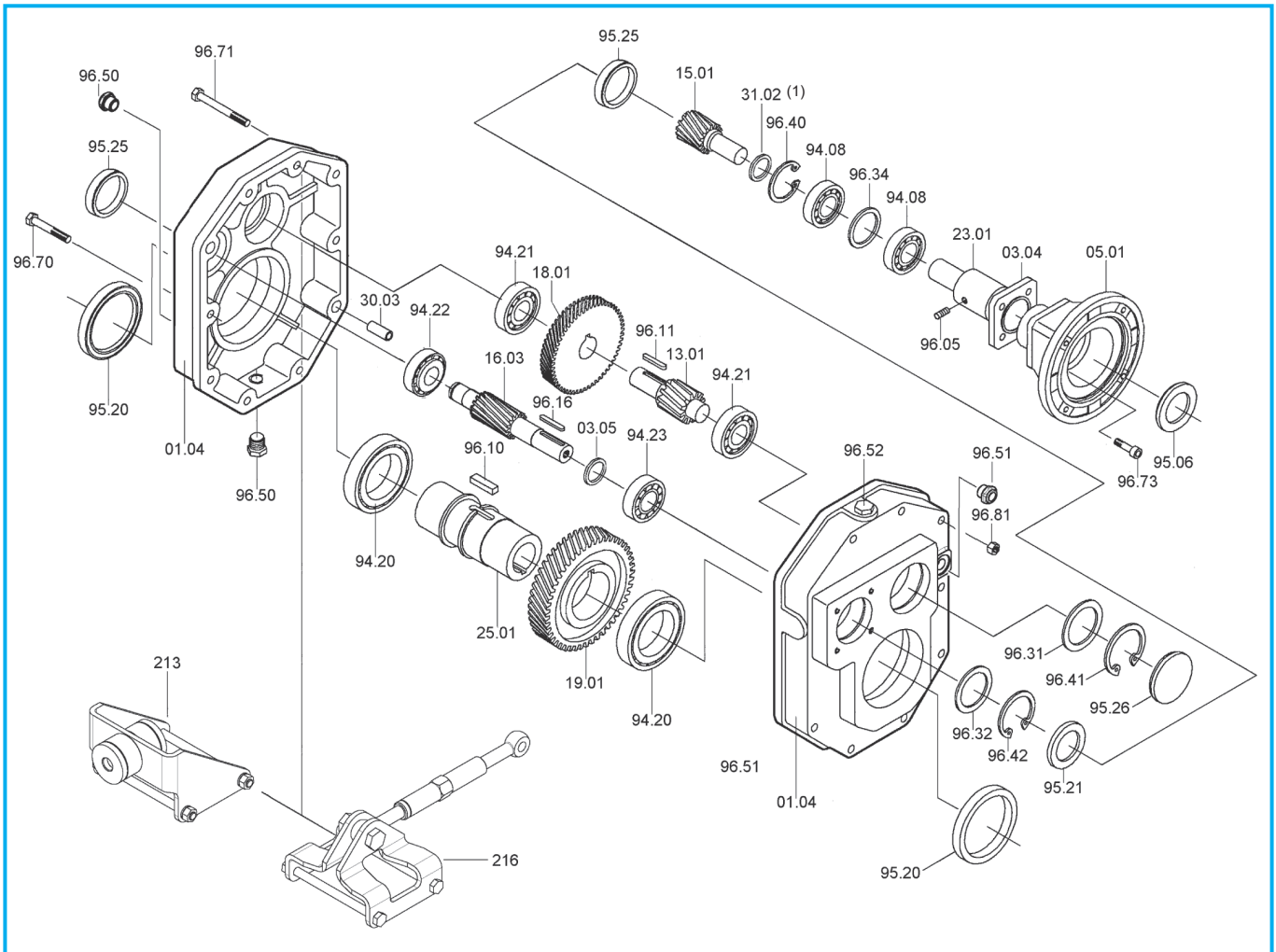

PA - PC	Cuscinetti / Bearings / Lager					Anelli di tenuta / Oilseals / Öldichtungen				
	PA - PC		PA	PC	PA - PC	PC		PA		
	94.20	94.21	94.22	94.23		94.08	95.20	IEC	95.06	95.21
<b>63B</b>	<b>6008</b> 40/68/15	<b>6302</b> 15/42/13	<b>6301</b> 12/37/21	<b>6302</b> 15/42/13	<b>7203</b> 17/40/12	40/62/7	<b>63</b>	<b>25/52/7</b>	<b>15/35/7</b>	
							<b>71</b>	<b>30/52/7</b>		
							<b>80</b>	<b>35/52/7</b>		
							<b>90</b>	<b>37/52/8</b>		
<b>80B</b>	<b>6210</b> 50/90/20	<b>6304</b> 20/52/15	<b>30302</b> 15/45/14.25	<b>30204</b> 20/47/15.25	<b>7205</b> 25/52/15	50/80/10	<b>71 - 80</b>	<b>35/62/7</b>	<b>20/47/7</b>	
							<b>90</b>	<b>40/62/7</b>		
							<b>100 - 112</b>	<b>45/62/8</b>		
<b>100B</b>	<b>6212</b> 60/110/22	<b>6305</b> 25/62/17	<b>30304</b> 20/52/16.25	<b>30205</b> 25/52/16.25	<b>7206</b> 30/62/16	60/100/13	<b>80 - 90</b>	<b>40/72/7</b>	<b>25/52/7</b>	
							<b>100 - 112</b>	<b>45/72/8</b>		
							<b>132</b>	<b>55/72/10</b>		
<b>125B</b>	<b>6215</b> 75/130/25	<b>6306</b> 30/72/19	<b>30305</b> 25/62/18.25	<b>30206</b> 30/62/17.25	<b>7207</b> 35/72/17	75/120/12	<b>80 - 90</b>	<b>45/80/10</b>	<b>30/62/7</b>	
							<b>100 - 112</b>	<b>45/80/10</b>		
							<b>132</b>	<b>55/80/10</b>		
							<b>160</b>	<b>60/80/8</b>		
<b>160B</b>	<b>6219</b> 95/170/32	<b>6307</b> 35/80/21	<b>30306</b> 30/72/20.75	<b>30208</b> 40/80/19.75	<b>7209</b> 45/85/38	95/136/13	<b>100 - 112</b>	<b>55/100/13</b>	<b>40/80/10</b>	
							<b>132 - 160</b>	<b>60/100/10</b>		
							<b>180</b>	<b>65/100/10</b>		
							<b>200</b>	<b>75/100/10</b>		

(1): Non presente su i=10, 12.5, 16, 18 / Not use for i=10, 12.5, 16, 18 / nicht verwendet i=10, 12.5, 16, 18



## PA..B

### Dispositivo antiritorno - Backstop device - Rücklaufsperr

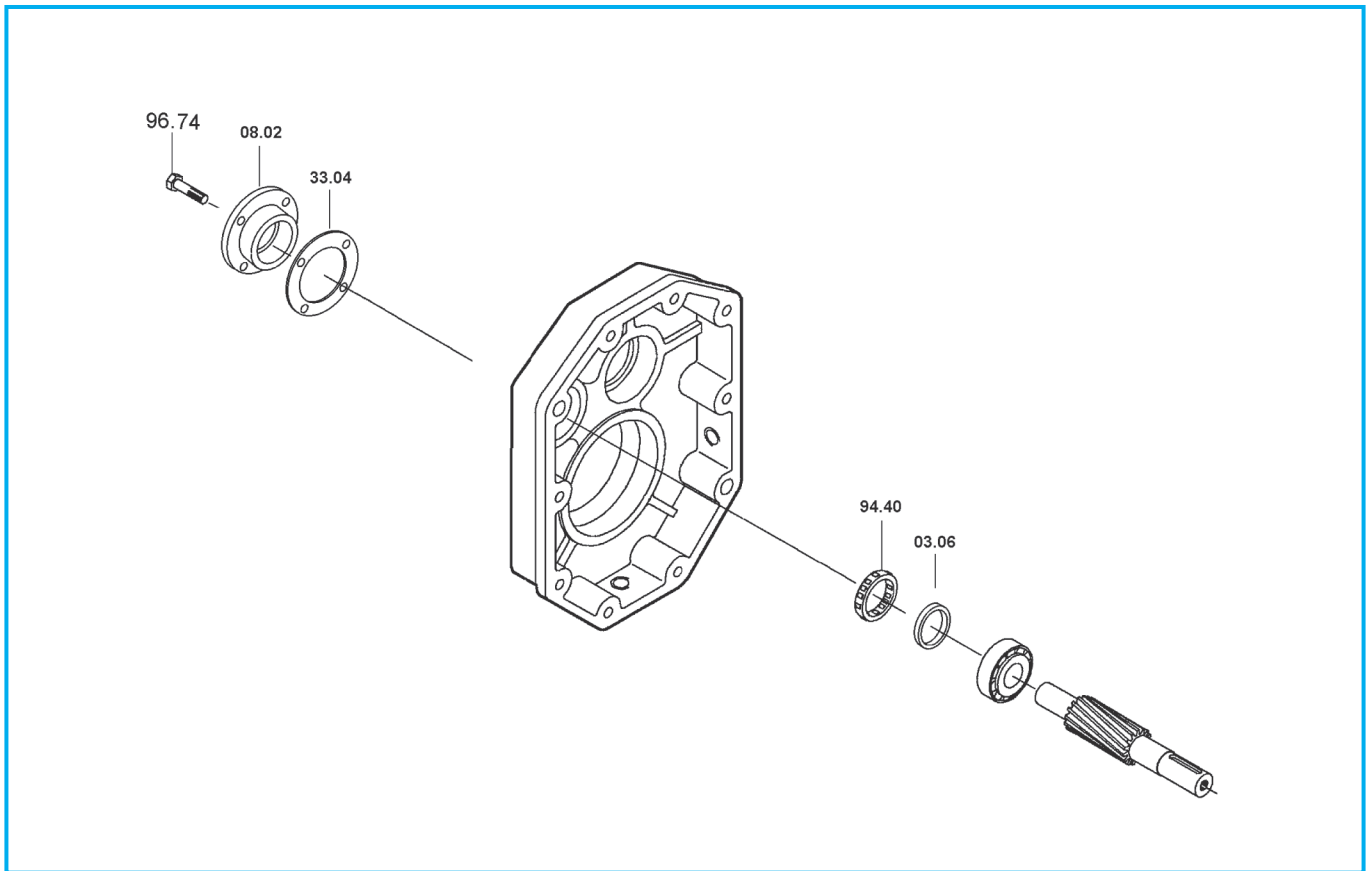

<b>P</b>	Ruota libera / Free wheel / Freilaufgrad 94.40
<b>80</b>	FE 423 Z
<b>100</b>	FE 428 Z
<b>125</b>	BF 50 Z 16
<b>160</b>	BF 70 Z 21



#### 4.13 Lista parti di ricambio

#### 4.13 Spare parts list

#### 4.13 Ersatzteilliste

In fase di ordine delle parti di ricambio, specificare sempre n° particolare (vedi disegno esploso), data (1), n° codice (2) e n° variante (3). (Vedi targhetta).

*When ordering a spare part, the spare part number (see exploded technical drawing), the date (1), the code number (2) and the variant number (3) should always be reported. (See plate)*

Bei der Bestellung von Ersatzteilen sind Ersatzteilnummer (s. Explosionszeichnung), Datum (1), Artikelnummer (2) und Variantennummer (3) anzugeben. (s. Schild)

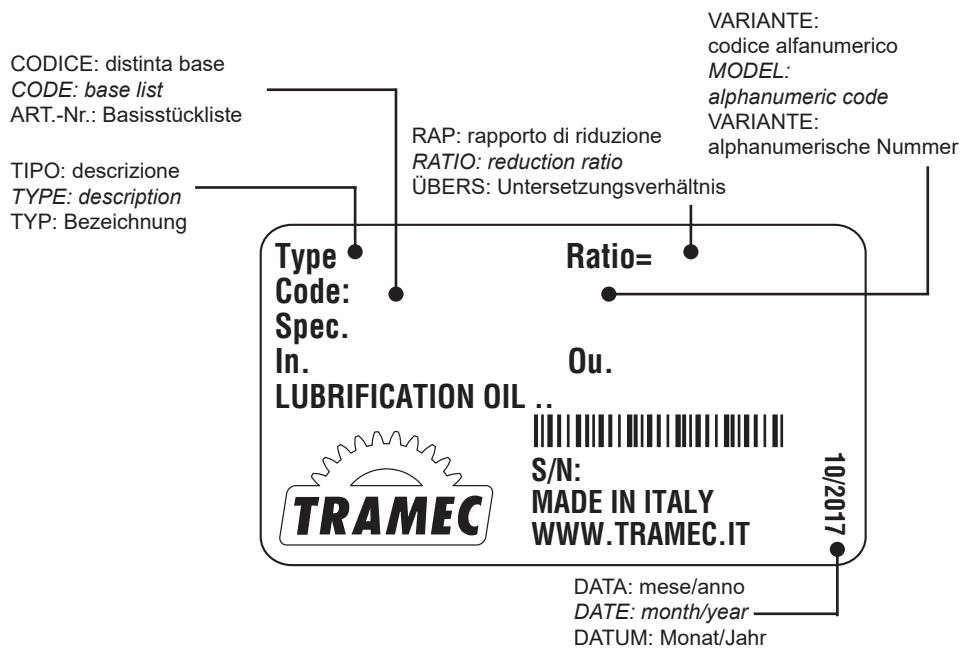





5.0	RIDUTTORI PENDOLARI MA	SHAFT-MOUNTED MA GEARBOX	AUFSTECKGETRIEBE MA	
5.1	Caratteristiche	<i>Characteristics</i>	Merkmale	86
5.2	Designazione	<i>Designation</i>	Bezeichnung	87
5.3	Velocità in entrata	<i>Input speed</i>	Antriebsdrehzahl	87
5.4	Rendimento	<i>Efficiency</i>	Wirkungsgrad	87
5.5	Potenza termica	<i>Thermal power</i>	Thermische Leistung	88
5.6	Giochi angolari	<i>Angular backlash</i>	Winkelspiel	88
5.7	Dati tecnici	<i>Technical data</i>	Technische Daten	88
5.8	Dimensioni	<i>Dimensions</i>	Abmessungen	89
5.9	Accessori	<i>Accessories</i>	Zubehör	89
5.10	Lubrificazione	<i>Lubrication</i>	Schmierung	91
5.11	Carichi radiali e assiali	<i>Radial and axial loads</i>	Radial- und Axialbelastungen	91
5.12	Lista parti di ricambio	<i>Spare parts list</i>	Ersatzteilliste	92

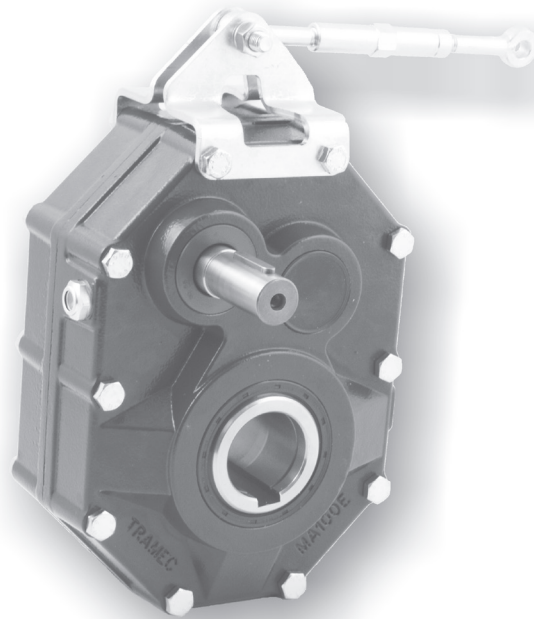

**MA..**





## 5.1 Caratteristiche

- Costruiti in 7 grandezze a due stadi di riduzione, sono previsti per fissaggio pendolare con tenditore. Sono predisposti per l'applicazione di un dispositivo antiritorno.
- E' previsto un albero entrata sporgente con linguetta per il montaggio di puleghe per trasmissioni a cinghia.
- La struttura rigida del corpo del riduttore, in ghisa meccanica, assicura un'ottima resistenza alle sollecitazioni e possiede un'unica camera di lubrificazione per una efficace dissipazione termica.
- Gli ingranaggi cilindrici, a dentatura elicoidale, sono costruiti in acciaio 16NiCr4, 18NiCrMo5 o 20MnCr5 UNI EN 10084 cementati e temprati, tutti rettificati entro la classe di qualità 6 della DIN 3962.
- L'albero lento cavo di serie in acciaio è caratterizzato da un efficace dimensionamento che ne esalta le prestazioni in molteplici applicazioni.
- Il corpo riduttore, le flange ed i coperchi vengono verniciati esternamente di colore BLU RAL 5010.

## 5.1 Characteristics

- *Available in 7 sizes with two reduction stages, shaft-mounting occurs by means of tension arm. A back-stop device can also be mounted if required by the application.*
- *A projecting input shaft with key is available for the mounting of pulleys for belt transmissions.*
- *The rigid structure of the housing in engineering cast iron ensures superior resistance to stress. The single lubrication chamber guarantees excellent thermal dissipation.*
- *The helical spur gears are built in 16NiCr4, 18NiCrMo5 or 20MnCr5 UNI EN 10084 quench-hardened and case-hardened steel, all ground according to quality 6 DIN 3962.*
- *The standard hollow output shaft made of steel is dimensioned to enhance the performance in all different applications.*
- *Gearbox housing, flanges and covers are externally painted with BLUE RAL 5010.*

## 5.1 Merkmale



- Die Getriebe sind in 7 Größen mit zwei Untersetzungsstufen erhältlich. Der Einbau erfolgt mit einer Drehmomentstütze. Wenn nötig kann eine Rücklaufsperre montiert werden.
- Eine vorstehende Antriebswelle mit Feder dient zum Einbau von Riemenscheiben.
- Die starre Struktur des Gehäuses aus Maschinenguß sichert ausgezeichnete Schwingungsfestigkeit. Eine einzige Schmierkammer sichert höhere Wärmedissipation.
- Die Schrägstirnräder bestehen aus einsatz- und abschreckgehärtetem 16NiCr4, 18NiCrMo5-oder 20MnCr5-Stahl UNI EN 10084, geschliffen innerhalb Qualitätsklasse 6 der Spez. DIN 3962.
- Die Standard-Abtriebshohlwelle aus Stahl ist so dimensioniert, um die beste Leistungen in allerlei Applikationen zu erhalten.
- Getriebegehäuse, Flansche und Deckel werden mit BLAU RAL 5010 lackiert.



## 5.2 Designazione

## 5.2 Designation

## 5.2 Bezeichnung

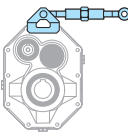
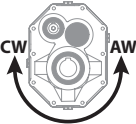
Macchina Machine Maschine	Tipo entrata Input type Antriebsart	Grandezza Size Größe	Diametro albero lento Output shaft diameter Durchmesser der Abtriebswelle	Rotismo Gearing Räderwerk	Rapporto rid. Ratio Untersetzungsverhältnis	Tenditore Tensioner Spannvorrichtung	Esecuzione Execution Ausführung	Posizione di montaggio Mounting position Baulage	Antiritorno Back-stop device Rücklaufsperre
<b>M</b>	<b>A</b>	<b>100</b>	<b>55</b>	<b>B</b>	<b>10/1</b>	<b>TE</b>	<b>O</b>	<b>P1</b>	<b>CW</b>
Riduttore pendolare Shaft mounted gearbox Aufsteckgetriebe	 <b>A</b>	<b>63</b> <b>80</b> <b>100</b> <b>125</b> <b>140</b> <b>160</b> <b>180</b>	<b>D<sub>2</sub></b> <b>35 ÷ 100</b>	<b>B</b> 	<b>i<sub>n</sub></b> = <b>12.5 ÷ 25</b>		<b>O</b>	<b>P1</b> <b>P2</b> <b>P3</b> <b>P4</b>	

## 5.3 Velocità in entrata

## 5.3 Input speed

## 5.3 Antriebsdrehzahl

Tutte le prestazioni dei riduttori sono calcolate in base ad una velocità in entrata di 1400 min<sup>-1</sup>.

Nella tabella sottostante riportiamo i coefficienti correttivi della potenza in entrata P alle varie velocità riferita ad F<sub>s</sub> = 1

All calculations of gear unit performance are based on an input speed of 1400 min<sup>-1</sup>. The table below reports input power P corrective coefficients at the various speeds, with F<sub>s</sub> = 1.

Bei der Berechnung der Getriebeleistungen wurde eine Antriebsdrehzahl von 1400 min<sup>-1</sup> zugrunde gelegt. In der folgenden Tabelle finden Sie die Korrekturkoeffizienten für die Antriebsleistung P bei den verschiedenen Drehzahlen, bezogen auf F<sub>s</sub> = 1.

Tab. 1

n <sub>1</sub> [min <sup>-1</sup> ]	1400	900	700	500
P <sub>c</sub> (kW)	P x 1	P x 0.7	P x 0.56	P x 0.42

## 5.4 Rendimento

## 5.4 Efficiency

## 5.4 Wirkungsgrad

Il valore del rendimento dei riduttori può essere stimato con sufficiente approssimazione, trascurando le variazioni non significative attribuibili ai vari rapporti.

The efficiency value of the gearbox can be estimated, ignoring non-significant variations which can be attributed to the various ratios.

Der Wirkungsgrad des Getriebes kann mit ausreichender Annäherung aufgrund der Anzahl der Untersetzungsstufen ermittelt werden. Dabei können die unwesentlichen Veränderungen, die auf die verschiedenen Größen und Untersetzungsverhältnisse zurückzuführen sind, ausser Acht gelassen werden.

η	<b>M...B</b>
	0.95



### 5.5 Potenza termica

I valori delle potenze termiche,  $P_{10}$  (kW), relative alle diverse grandezze di riduttori pendolari sono riportati nella tabella seguente in funzione della velocità di rotazione in entrata del riduttore.

Tab. 2

$n_1$ [min <sup>-1</sup> ]	$P_{10}$ [kW] - Potenza Termica / Thermal power / Thermische Leistung						
	MA63B	MA80B	MA100B	MA125B	MA140B	MA160B	MA180B
1400	3.6	5.1	7.3	10.5	13.8	19.3	27.2

### 5.6 Giochi angolari

Bloccando l'albero di entrata, il gioco viene misurato sull'albero uscita ruotandolo nelle due direzioni ad applicando la coppia strettamente necessaria a creare il contatto tra i denti degli ingranaggi, al massimo pari al 2% della coppia massima garantita dal riduttore.

Nella tabella seguente sono riportati i valori indicativi del gioco angolare (in minuti di angolo).

### 5.5 Thermal power

The following table shows the values of thermal power  $P_{10}$  (kW) for each gearbox size based on rotation speed at gearbox input.

### 5.6 Angular backlash

After having blocked the input shaft, the angular backlash can be measured on the output shaft by rotating it in both directions and applying the torque which is strictly necessary to create a contact between the teeth of the gears. The applied torque should be at most 2% of the max. torque guaranteed by the gearbox.

The following table reports the approximate values of the angular backlash (in minutes of arc).

### 5.5 Thermische Leistung

Die folgende Tabelle enthält die Werte  $P_{10}$  der thermischen Leistung (kW) je nach Getriebegröße und abhängig von Drehzahlen am Getriebeantrieb.

### 5.6 Winkelspiel

Nachdem die Antriebswelle blockiert worden ist, kann das Winkelspiel an der Abtriebswelle gemessen werden. Dabei soll die Abtriebswelle in den beiden Richtungen gedreht und ein Drehmoment ausgeübt werden, das zur Entstehen eines Kontaktes zwischen den Zähnen genügt. Das ausgeübte Drehmoment soll höchstens 2% des max. vom Getriebe garantierten Drehmoment sein.

Die folgende Tabelle weist die Näherungswerte des Winkelspiels (in Bogenminuten).

Gioco angolare / Backlash / Winkelspiel (1')	
M..B	16-20

### 5.7 Dati tecnici

### 5.7 Technical data

### 5.7 Technische Daten

MA	$n_1 = 1400$			MA		
	in	ir	$n_2$ rpm	$T_{2M}$ Nm	P kW	J kg·cm <sup>2</sup>
63B	12.5	12.83	109	300	3.5	0.75
	16	16.01	87	340	3.0	0.70
	20	20.66	68	370	2.7	0.64
	25	25.17	56	380	2.2	0.62
80B	12.5	12.91	108	680	7.9	1.68
	16	16.55	85	710	6.5	1.55
	20	19.99	70	740	5.5	1.46
	25	24.80	56	750	4.5	1.41
100B	12.5	12.91	108	1100	12.5	4.05
	16	16.55	85	1150	10.5	3.73
	20	19.99	70	1200	9.0	3.51
	25	24.80	56	1250	7.6	3.36
125B	12.5	12.90	109	1900	22	10.77
	16	16.53	85	2050	19	9.99
	20	19.97	70	2100	16	9.47
	25	24.78	56	2150	13.5	9.10
140B	12.5	12.91	108	3050	35.5	20.32
	16	16.55	85	3200	29	18.82
	20	19.99	70	3280	25.4	17.68
	25	24.80	56	3350	20.9	16.99
160B	12.5	13.38	105	4900	55.5	37.11
	16	17.13	82	5100	45	34.05
	20	20.67	68	5200	38	31.78
	25	25.62	55	5300	31.5	30.42
180B	12.5	13.15	106	7800	89	84.48
	16	16.86	83	8200	73.5	78.16
	20	20.37	69	8400	62.5	73.74
	25	25.27	55	8600	51	70.78

Verifica termica necessaria /  
Thermal rating needed /  
Thermische - Prüfung erforderlich



### 5.8 Dimensioni

### 5.8 Dimensions

### 5.8 Abmessungen

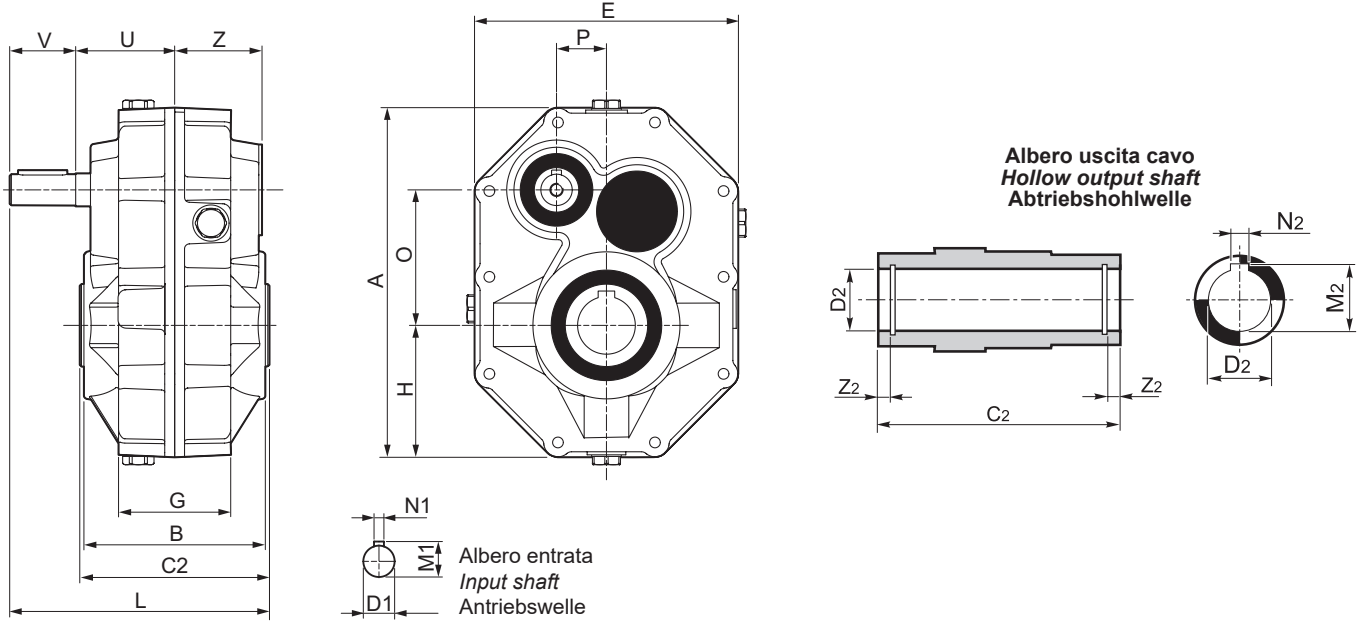

	MA													
	63B		80B		100B		125B		140B		160B		180B	
<b>A</b>	212		255		305		367		425		490		570	
<b>B</b>	110		126		150		175		202		252		288	
<b>C2</b>	115		130		155		180		210		260		300	
<b>D2</b>	<b>35</b>	38	<b>40</b>	45	<b>50</b>	55	<b>60</b>	65	<b>70</b>	75	<b>80</b>	85	<b>90</b>	100
<b>M2</b>	38.3	41.3	43.3	48.8	53.8	59.3	64.4	69.4	74.9	79.9	85.4	90.4	95.4	106.4
<b>N2</b>	10	10	12	14	14	16	18	18	20	20	22	22	25	28
<b>E</b>	160		190		224		270		310		367		440	
<b>G</b>	68		82		102		118		134		166		200	
<b>H</b>	80		95		112		135		155		183.5		220	
<b>O</b>	82.13		96.6		118.35		139.36		161.11		187.76		212.86	
<b>P</b>	30.27		35.97		41.79		50.66		60.36		72.89		79.62	
<b>D1</b>	19		24		28		38		38		42		48	
<b>M1</b>	21.5		27		31		41		41		45		51.5	
<b>N1</b>	6		8		8		10		10		12		14	
<b>V</b>	40		50		60		80		80		80		80	
<b>L</b>	157.5		182.5		217.5		262.5		292.5		342.5		382.5	
<b>U</b>	60		67.5		80		92.5		107.5		132.5		152.5	
<b>Z</b>	53		61		73		85		94		119		134	
<b>Z2</b>	6.9	6.9	8.2	8.2	10.4	10.4	11.9	11.4	15.4	15.4	15.4	14.9	16.9	16.9
<b>Kg</b>	12		18		30		51		73		120		190	

### 5.9 Accessori

### 5.9 Accessories

### 5.9 Zubehör

#### Tenditore

#### Tensioner

#### Spannvorrichtung

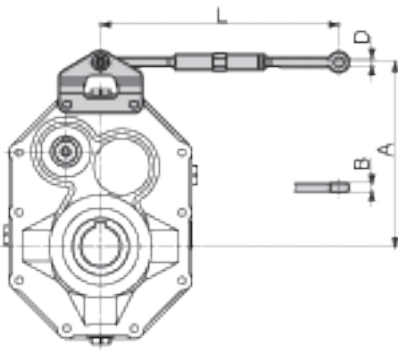

	MA						
	63B	80B	100B	125B	140B	160B	180B
<b>A</b>	160	195	244.5	293	336.5	380	445
<b>B</b>	8	10	12	14	16	16	22
<b>D</b>	8	10	12	14	16	16	18
<b>Lmax</b>	256	270	265	275	280	280	340
<b>Lmin</b>	210	224	214	220	230	230	280



**Kit fissaggio e smontaggio  
riduttori con albero lento cavo**

**Kit for the mounting and dismounting  
of the gearboxes with hollow output  
shaft**

**Kit für Montage und Ausbau der  
Getriebe mit Abtriebshohlwelle**

	MA													
	63B		80B		100B		125B		140B		160B		180B	
<b>C2</b>	115		130		155		180		210		260		300	
<b>D2</b>	35	38	40	45	50	55	60	65	70	75	80	85	90	100
<b>H</b>	6.5		8		9		12	11.5	12		15.5	15	16	17
<b>d1</b>	—		—		M10		M12		M12		M16		M16	M18
<b>d2</b>	—		—		M8		M10		M10		M12		M12	M16
<b>d3</b>	M8		M8		—		—		—		—		—	
<b>d4</b>	M12		M12		—		—		—		—		—	
<b>Z2</b>	6.9		8.2		10.4		11.9	11.4	15.4		15.4	14.9	16.9	
<b>Lmax</b>	99		111		132		153		179		225		262	
<b>Lmin</b>	96		108		127		148		172		215		252	

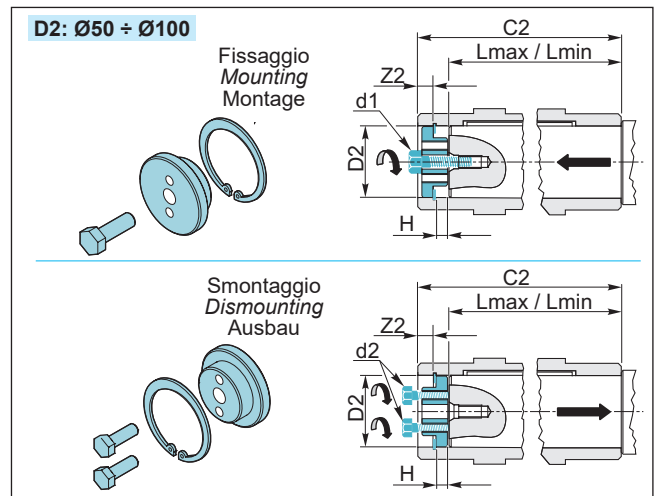
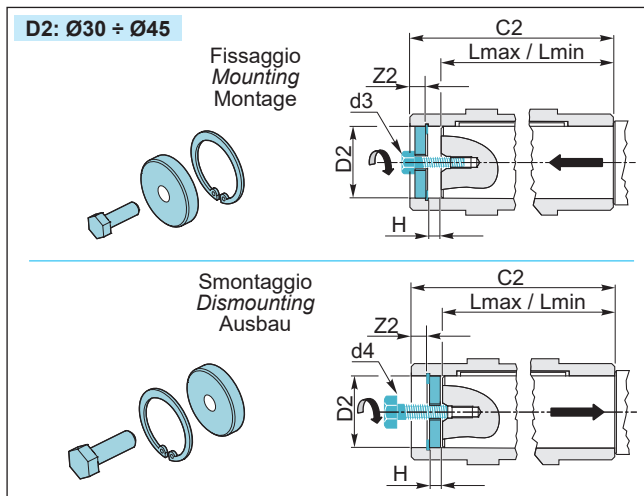

**Dispositivo antiritorno** (a richiesta)

**Backstop device** (on request)

**Rücklaufsperr** (Auf Anfrage)

Il riduttore pendolare presenta valori di rendimento statico (e dinamico) molto elevati:

per questo motivo non è garantita spontaneamente l'irreversibilità statica.

L'irreversibilità statica si realizza quando, a riduttore fermo, l'applicazione di un carico all'albero lento non pone in rotazione l'asse entrata. Pertanto, per garantire l'irreversibilità del moto, a riduttore fermo, occorre predisporre il riduttore stesso con un opportuno dispositivo antiritorno, fornibile a richiesta. Tale dispositivo permette la rotazione dell'albero lento solo nel senso desiderato, da specificare in fase di ordine.

Nel caso in cui sia presente il dispositivo antiritorno è necessario l'utilizzo di olio lubrificante sintetico, classe di viscosità ISO 150.

L'irreversibilità è garantita dal dispositivo antiritorno per coppie applicate all'albero uscita pari alla  $T_{2M}$  del riduttore.

Shaft-mounted gearboxes feature quite high values of static (and dynamic) efficiency: for this reason spontaneous static irreversibility is not guaranteed. Static irreversibility, with motionless gearbox, occurs when the application of a load on the output shaft does not cause rotation of the input axis. In order to guarantee motion irreversibility, with motionless gearbox, it is necessary to fit a backstop device, available on request only. The backstop device enables rotation of the out put shaft only in the required direction, which is to be specified when ordering.

The utilization of synthetic oil, viscosity class ISO 150, is necessary for the gearboxes equipped with back stop device.

The irreversibility is guaranteed by the back stop device for torques applied to the output shaft equal to  $T_{2M}$  of the gearbox.

Aufsteckgetriebe haben sehr hohen statischen (und dynamischen) Wirkungsgrad: deshalb wird keine spontane statische Irreversibilität garantiert. Statische Irreversibilität bei stillstehenden Getriebe hat man, wenn die Applikation bei einer Last auf die Abtriebswelle keine Drehung der Antriebswelle verursacht. Um Irreversibilität der Bewegung bei stillstehendem Getriebe zu sichern, sollte eine Rücklaufsperr montiert werden.

Die Rücklaufsperr ermöglicht, dass die Abtriebswelle nur in der gewünschten Richtung dreht (gewünschte Richtung beim Bestellen angeben) und wird auf Wunsch geliefert.

Die Getriebe mit einer Rücklaufsperr müssen mit synthetischem Öl (Viskosität ISO150) betrieben werden.

Falls die Drehmomente am Abtrieb zum  $T_{2M}$  des Getriebes gleichwertig sind, dann ist die Irreversibilität durch die Rücklaufsperr garantiert.

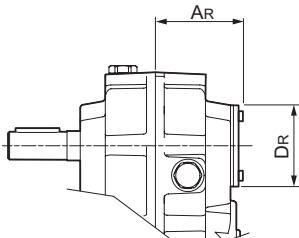

	MA							
	63B	80B	100B	125B	140B	160B	180B	
<b>A<sub>R</sub></b>	63.5	71.5	84.5	98.5	109	136	152.5	
<b>D<sub>R</sub></b>	55	65	70	85	100	120	120	



### 5.10 Lubrificazione

I riduttori pendolari sono forniti predisposti per lubrificazione a olio e muniti dei tappi di carico, livello e scarico olio. Si raccomanda di precisare sempre la posizione di montaggio desiderata in fase di ordine.

#### Posizione di montaggio e quantità di lubrificante (litri)

I quantitativi di olio riportati nella tabella sono indicativi e riferiti alle posizioni di lavoro indicate e considerando le condizioni di funzionamento a temperatura ambiente e velocità in ingresso di 1400 min<sup>-1</sup>. Per condizioni di lavoro diverse da quelle sopra riportate contattare il servizio tecnico.

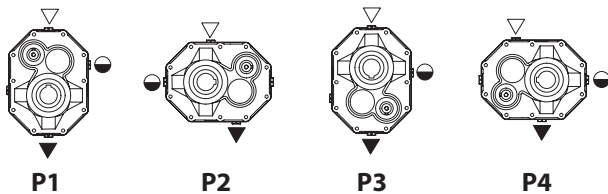

### 5.10 Lubrication

Shaft-mounted gearboxes require oil lubrication and are equipped with filler, level and drain plugs. The mounting position should always be specified when ordering the gearbox.

#### Mounting positions and lubricant quantity (litres)

The oil quantities stated in the table are approximate values and refer to the indicated working positions, considering operating conditions at ambient temperature and an input speed of 1400 min<sup>-1</sup>. Should the operating conditions be different, please contact the technical service.

	MA						
	63B	80B	100B	125B	140B	160B	180B
P1	0.55	1.2	2.2	4.4	6.2	9.9	10.2
P2	0.45	0.9	1.8	3.6	6.6	7.2	10.4
P3	0.55	1.1	2.2	4.4	6.2	8.8	10.2
P4	0.45	0.9	1.8	3.6	6.6	7.2	10.4

### 5.10 Schmierung

Die Aufsteckgetriebe sind für die Ölschmierung mit Einfüll-, Ölstand- und Ablaßstopfen versehen. Bei der Bestellung ist immer die gewünschte Montageposition anzugeben.

#### Montageposition und Ölmenge (Liter)

Die in der Tabelle angegebenen Daten sind Richtwerte. Die Ölmengen beziehen sich auf die angegebene Betriebsposition. Dabei werden Betrieb bei Umgebungstemperatur und Antriebsdrehzahl von 1400 min<sup>-1</sup> berücksichtigt. Falls die Betriebsbedingungen anders sind, dann ist das technische Büro zu befragen.

### 5.11 Carichi radiali e assiali (N)

Le trasmissioni effettuate tramite pignoni per catena, ruote dentate o pulegge generano delle forze radiali (F<sub>R</sub>) sugli alberi dei riduttori. L'entità di tali forze può essere calcolata con la formula:

### 5.11 Radial and axial loads (N)

Transmissions implemented by means of chain pinions, wheels or pulleys generate radial forces (F<sub>R</sub>) on the gear unit shafts. The entity of these forces may be calculated using the following formula:

$$F_R = \frac{K_R \cdot T}{d} \text{ [N]}$$

dove:

T = Momento torcente [Nm]  
d = Diametro pignone o puleggia [mm]

K<sub>R</sub> = 2000 per pignone per catena  
= 2500 per ruote dentate  
= 3000 per puleggia con cinghie a V

where:

T = torque [Nm]  
d = pinion or pulley diameter [mm]

K<sub>R</sub> = 2000 for chain pinion  
= 2500 for wheel  
= 3000 for V-belt pulley

### 5.11 Radial- und Axialbelastungen (N)

Antriebe mit Kettenritzel, Zahnrädern oder Riemscheiben erzeugen radiale Kräfte (F<sub>R</sub>) an den Wellen der Untersetzungsgetriebe. Das Ausmaß dieser Kräfte kann nach folgender Formel berechnet werden:

dabei ist:

T = Drehmoment [Nm]  
d = Kettenritzel- bzw. Riemscheiben durchmesser [mm]

K<sub>R</sub> = 2000 bei Kettenritzel  
= 2500 bei Zahnrad  
= 3000 bei Riemscheibe mit Keilriemen

I valori dei carichi radiali e assiali generati dall'applicazione debbono essere sempre minori o uguali a quelli ammissibili indicati nelle tabelle.

The values of the radial and axial loads generated by the application must always be lower than or equal to the admissible values reported in the tables.

Die Werte der Radial- und Axialbelastungen, die durch die Anwendung hervorgerufen werden, dürfen nicht über den in den Tabellen angegebenen zulässigen Werten liegen.

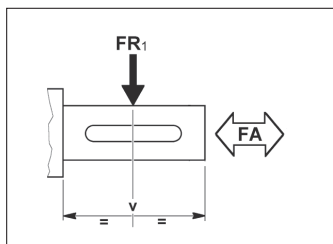

i <sub>n</sub>		MA						
		63B	80B	100B	125B	140B	160B	180B
		ALBERO ENTRATA / INPUT SHAFT / ANTRIEBSWELLE (n <sub>1</sub> = 1400 min <sup>-1</sup> )						
Tutti All Alle	Fr <sub>1</sub>	360	470	710	1040	1400	1940	2200
	Fa <sub>1</sub>	72	94	142	208	280	388	440

I carichi radiali indicati nelle tabelle si intendono applicati a metà della sporgenza dell'albero e sono riferiti ai riduttori operanti con fattore di servizio 1.

The radial load reported in the table are considered as applied at the half-way point of the shaft projection and refer to gear units operating with service factor 1.

Die Radialbelastungen, die in den Tabellen angegeben werden, gelten für Ansatzpunkte in der Mitte des herausragenden Wellenteils und für Getriebe mit Betriebsfaktor 1.



**MA..B**

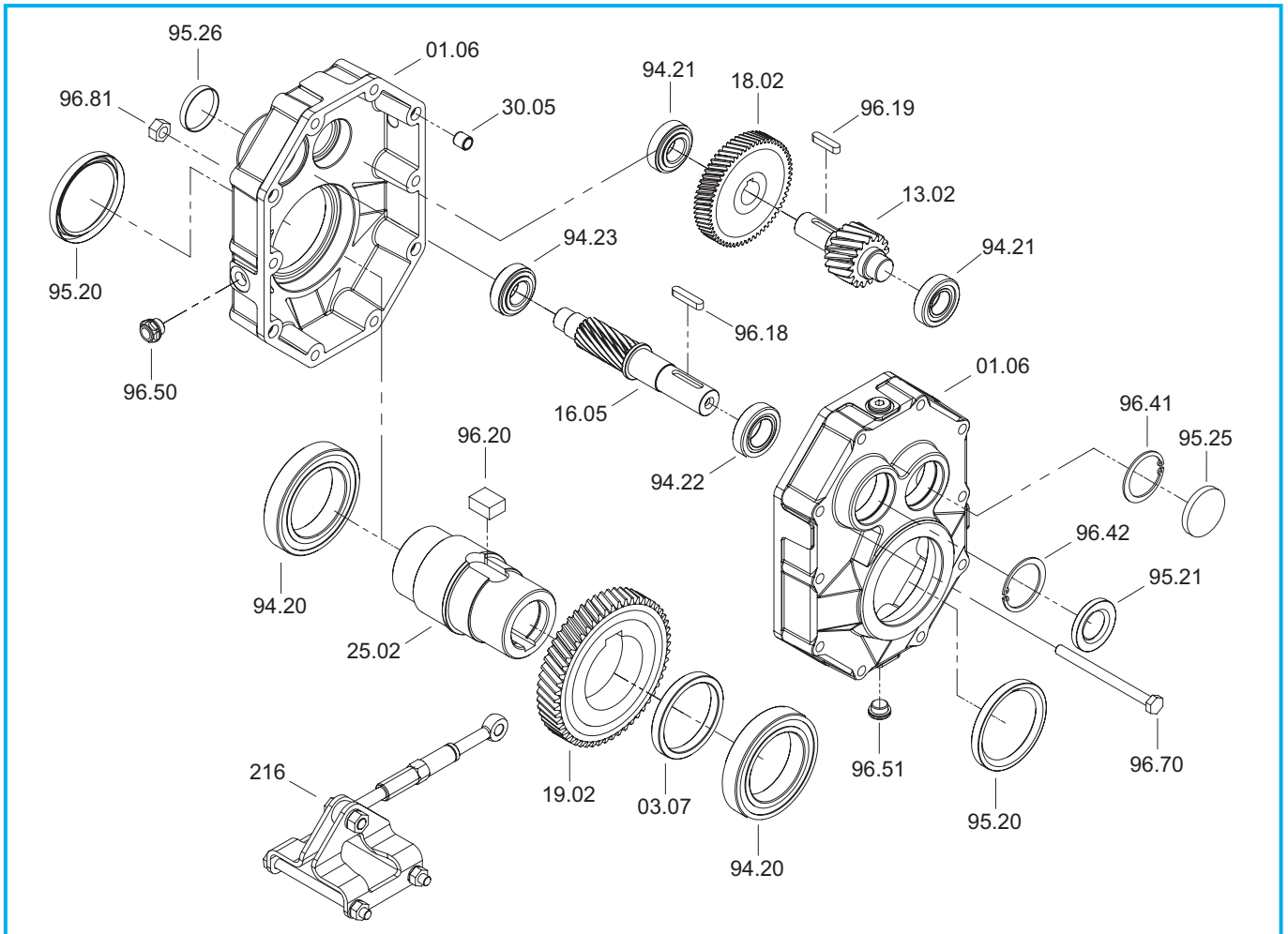

MA	Cuscinetti / Bearings / Lager				Anelli di tenuta / Oilseals / Öldichtungen	
	94.20	94.21	94.22	94.23	95.20	95.21
<b>63B</b>	<b>6010</b> 50/80/16	<b>6303</b> 17/47/14	<b>6004</b> 20/42/12	<b>6203</b> 17/40/12	50/65/8	<b>20/42/7</b>
<b>80B</b>	<b>6012</b> 60/95/18	<b>30204</b> 20/47/15.25	<b>6205</b> 25/52/15	<b>6204</b> 20/47/14	60/75/8	<b>25/52/7</b>
<b>100B</b>	<b>6015</b> 75/115/20	<b>30205</b> 25/52/16.25	<b>32006</b> 30/55/17	<b>30205</b> 25/52/16.25	75/95/10	<b>30/55/7</b>
<b>125B</b>	<b>6018</b> 90/140/24	<b>30206</b> 30/62/17.25	<b>32008</b> 40/68/19	<b>30206</b> 30/62/17.25	90/110/12	<b>40/68/10</b>
<b>140B</b>	<b>6219</b> 95/170/32	<b>30207</b> 35/72/18.25	<b>30208</b> 40/80/19.75	<b>30207</b> 35/72/18.25	95/125/12	<b>40/80/10</b>
<b>160B</b>	<b>6222</b> 110/200/38	<b>32208</b> 40/80/24.75	<b>32209</b> 45/85/24.75	<b>32208</b> 40/80/24.75	110/130/12	<b>45/85/10</b>
<b>180B</b>	<b>6226</b> 130/230/40	<b>33210</b> 50/90/32	<b>32210</b> 50/90/24.75	<b>32209</b> 45/85/24.75	130/160/12	<b>50/90/10</b>

## MA..B

### Dispositivo antiritorno - Backstop device - Rücklaufsperr

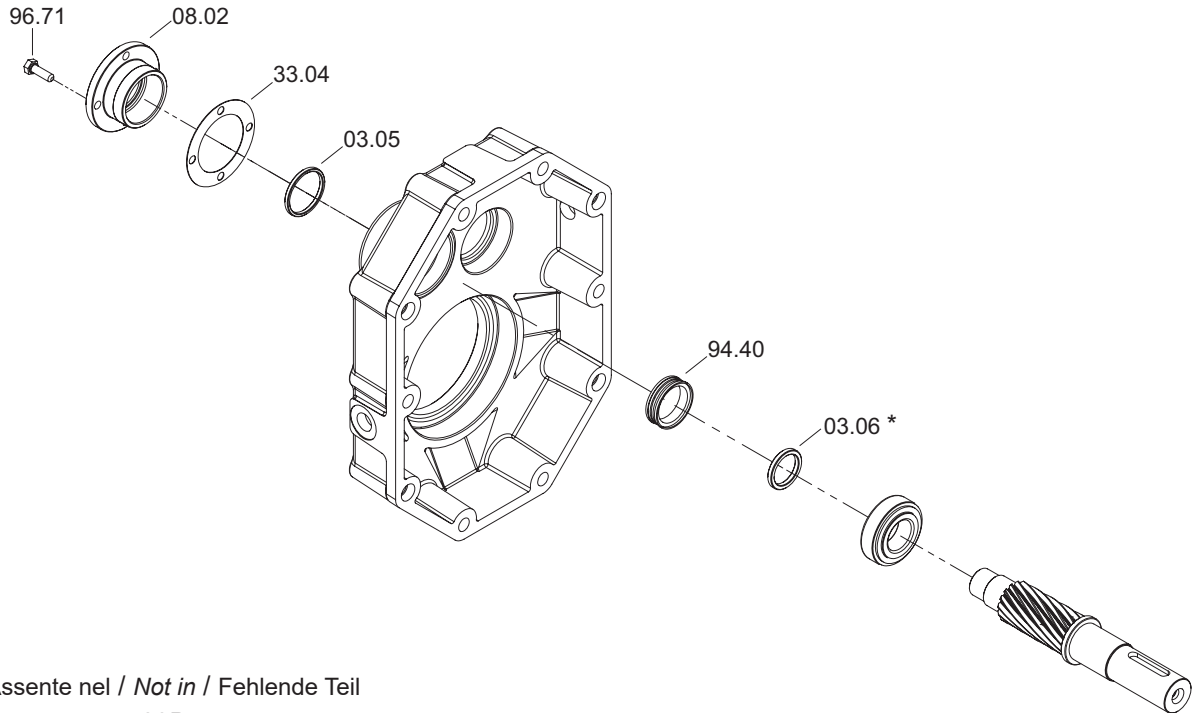

\* Assente nel / Not in / Fehlende Teil

63B

80B

MA	Ruota libera / Free wheel / Freilaufgrad 94.40
<b>63B</b>	FE 423 Z
<b>80B</b>	FE 428 Z
<b>100B</b>	BF 50 Z 16
<b>125B</b>	BF 71 Z 16
<b>140B</b>	SF 31-13,5/12J
<b>160B</b>	BF 90 Z 21
<b>180B</b>	FE 8044 Z 19





## 5.12 Lista parti di ricambio

## 5.12 Spare parts list

## 5.12 Ersatzteilliste

In fase di ordine delle parti di ricambio, specificare sempre n° particolare (vedi disegno esploso), data (1), n° codice (2) e n° variante (3). (Vedi targhetta).

*When ordering a spare part, the spare part number (see exploded technical drawing), the date (1), the code number (2) and the variant number (3) should always be reported. (See plate)*

Bei der Bestellung von Ersatzteilen sind Ersatzteilnummer (s. Explosionszeichnung), Datum (1), Artikelnummer (2) und Variantennummer (3) anzugeben. (s. Schild)

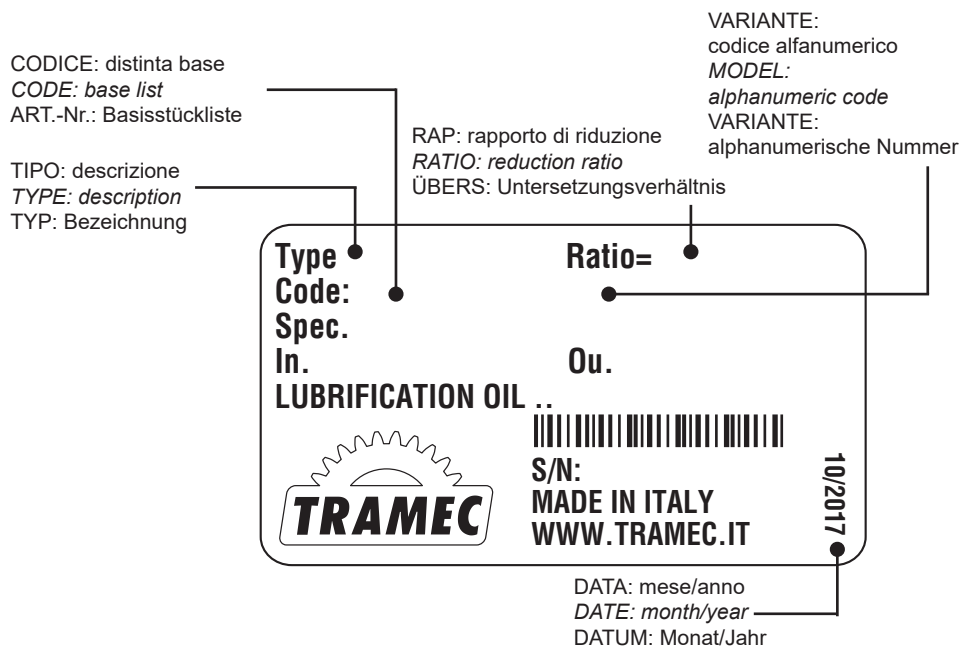

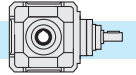

**6.0 RINVII ANGOLARI R      RIGHT ANGLE GEARBOX R      WINKELGETRIEBE R**

6.1	Caratteristiche	<i>Characteristics</i>	Merkmale	96
6.2	Designazione	<i>Designation</i>	Bezeichnung	97
6.3	Velocità in entrata	<i>Input speed</i>	Antriebsdrehzahl	97
6.4	Rendimento	<i>Efficiency</i>	Wirkungsgrad	98
6.5	Giochi angolari	<i>Angular backlash</i>	Winkelspiel	98
6.6	Potenza termica	<i>Thermal power</i>	Thermische Leistung	98
6.7	Dati tecnici	<i>Technical data</i>	Technische Daten	99
6.8	Senso di rotazione alberi	<i>Direction of shaft rotation</i>	Drehrichtungen der Wellen	99
6.9	Momenti d'inerzia	<i>Moments of inertia</i>	Trägheitsmoment	100
6.10	Dimensioni	<i>Dimensions</i>	Abmessungen	102
6.11	Accessori	<i>Accessories</i>	Zubehör	104
6.12	Lubrificazione	<i>Lubrication</i>	Schmierung	104
6.13	Carichi radiali e assiali (N)	<i>Radial and axial loads (N)</i>	Radial- und Axialbelastungen (N)	105
6.14	Lista parti di ricambio	<i>Spare parts list</i>	Ersatzteilliste	106

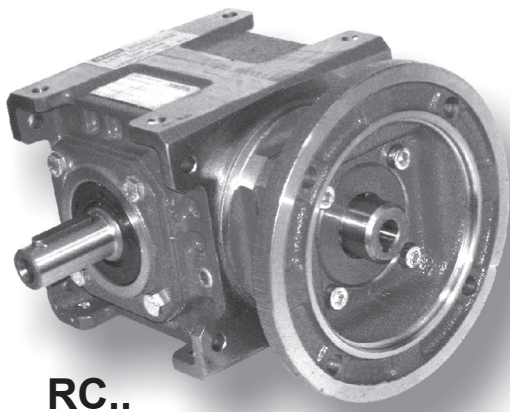

**RC..**

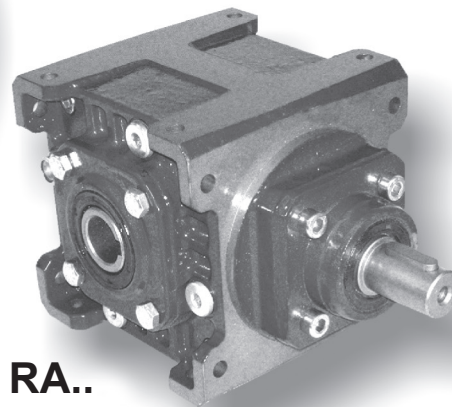

**RA..**

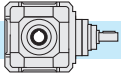

## 6.1 Caratteristiche

- Costruiti in 5 grandezze con tre tipi di albero uscita: cavo, sporgente, bisporgente. E' possibile inoltre disporre di un ulteriore albero di uscita opposto a quello di entrata.
- Sono previsti tre tipi di entrata: con albero sporgente, con predisposizione attacco motore (campana e giunto) e predisposizione attacco motore COMPACTA.
- Il corpo riduttore in ghisa meccanica EN GJL 200 UNI EN 1561 abbondantemente nervato all'interno e all'esterno per garantire la rigidità, è lavorato su tutti i piani per consentire un facile posizionamento; inoltre un'unica camera di lubrificazione garantisce una maggiore dissipazione termica e una migliore lubrificazione di tutti gli organi interni.
- Il cinematismo di questi rinvii è costituito da una coppia di ingranaggi conici a dentatura spiroidale GLEASON con profilo accuratamente rodato, in acciaio 16CrNi4 o 18NiCrMo5.
- L'utilizzo di cuscinetti di qualità su tutti gli assi, consente al riduttore di ottenere durate molto elevate e di sopportare elevati carichi radiali e assiali.
- Il corpo riduttore, le flange, le campane ed i coperchi vengono verniciati esternamente di colore BLU RAL 5010.

## 6.1 Characteristics

- *Built in 5 sizes with three types of output shaft : hollow, projecting or double-extended. Moreover, an additional output shaft can be installed opposite to the input shaft.*
- *Three input types are available : with projecting input shaft, with pre-engineered motor coupling (bell and joint) and pre-engineered COMPACT motor coupling.*
- *Gear unit body in engineering cast iron, EN GJL 200 UNI EN 1561 ribbed internally and externally to guarantee rigidity and machined on all surfaces for easy positioning. The single lubrication chamber guarantees improved heat dissipation and better lubrication of all the internal components.*
- *The mechanism of these gearboxes consists of two GLEASON spiral bevel gears with precision lapped profile, 16CrNi4 or 18NiCrMo5 made of steel.*
- *The use of high quality bearings on all the axis ensures long life to the gearbox and allows very high radial and axial loads.*
- *Gearbox housing, flanges, bells and covers are externally painted with BLUE RAL 5010.*

## 6.1 Merkmale

- Die Getriebe sind in 5 Baugrößen und 3 Abtriebsvarianten (Hohlwelle, einseitige Abtriebswelle und doppelseitige Abtriebswelle) erhältlich. Eine zusätzliche Abtriebswelle kann gegenüber dem Eintrieb montiert werden
- Drei Antriebsarten (Getriebeeingang) sind lieferbar: Eingangswelle, Motoranbau mit Glocke und Kupplung, Motor Direktanbau.
- Das Getriebegehäuse aus Maschinen- guß EN GJL 200 UNI EN 1561 ist sowohl innen als auch außen mit Rippen versehen, versehen, die die Steifheit leisten; die Bearbeitung aller Flächen ermöglicht eine leichte Positionierung; eine einzige Schmierkammer gewährleistet eine höhere Wärmedissipation und eine bessere Schmierung aller inneren Elemente.
- Die Vorgelege bestehen aus einem spiralverzahnten GLEASON-Kegelradpaar mit sorgfältig eingelaufenen Profil aus 16CrNi4- oder 18NiCrMo5-Stahl.
- An allen Achsen werden Qualitäts- Lager eingebaut. Diese gewährleisten eine hohe Lebensdauer und das Aushalten sehr hoher äußerer Radial- und Axialbelastungen.
- Getriebegehäuse, Flansche, Glocken und Deckel werden in BLAU RAL 5010 lackiert.

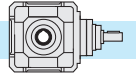

## 6.2 Designazione

## 6.2 Designation

## 6.2 Bezeichnung

Macchina Machine Maschine	Tipo entrata Input type Antriebsart	Grandezza Size Größe	Rotismo Gearing Räderwerk	Tipo uscita Output type Ausgang Typ	Rapporto rid. Ratio Untersetzungsverhältnis	Predisposizione att. mot. Motor coupling Motoranschluss	Entrata supplementare Additional input Zusatzantrieb	Rotazione alberi Shafts rotation Wellendrehrichtungen	Posizione di montaggio Mounting position Baulage	Flangia uscita Output flange Abtriebsflansch
<b>R</b>	<b>A</b>	<b>28</b>	<b>A</b>	<b>S</b>	<b>10</b>	<b>P.A.M.</b>	<b>S.e.A.</b>	<b>B</b>	<b>B3</b>	<b>FLD</b>
Rinvii angolari Right angle gearboxes Winkelgetriebe	A	19 24 28 38 48	A	S	$i_n =$ 1 2.5 5 10	63 ÷ 200	A	A B C D E F G H I L	B3 B6 B7 B8 VA VB	FLS
	C			B			C			FLD
	F			C			F			FL2

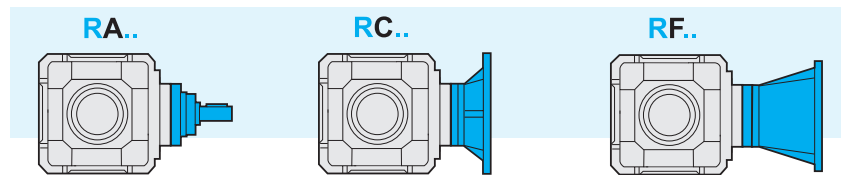

## 6.3 Velocità in entrata

Tutte le prestazioni dei riduttori sono calcolate in base ad una velocità in entrata di 1400 min<sup>-1</sup>.

La massima velocità ammessa in entrata è pari a 1400 min<sup>-1</sup>. Nel caso in cui tale limite debba essere superato contattare il servizio tecnico.

Nella tabella sottostante riportiamo i coefficienti correttivi della potenza in entrata P alle varie velocità riferita ad Fs =1

## 6.3 Input speed

All calculations of gear unit performance specifications are based on an input speed of 1400 min<sup>-1</sup>.

1400 min<sup>-1</sup> is the max. allowed input speed. For higher speed pls contact the technical service.

The table below shows the input power P corrective coefficients at the various speeds, with Fs =1.

## 6.3 Antriebsdrehzahl

Bei der Berechnung der Getriebeleistungen wurde eine Antriebsdrehzahl von 1400 min<sup>-1</sup> zugrunde gelegt.

1400 min<sup>-1</sup> ist die max. zulässige Antriebsdrehzahl. Falls die verlangte Antriebsdrehzahl höher ist, muss mit dem technischen Büro Rücksprache gehalten werden.

In der folgenden Tabelle finden Sie die Korrektorkoeffizienten für die Antriebsleistung P bei den verschiedenen Drehzahlen, bezogen auf Fs=1.

Tab. 1

n <sub>1</sub> [min <sup>-1</sup> ]	1400	900	700	500
P <sub>c</sub> (kW)	P x 1	P x 0.7	P x 0.56	P x 0.42

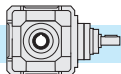

#### 6.4 Rendimento

Il valore del rendimento dei riduttori può essere stimato con sufficiente approssimazione (**R=0.97**), trascurando le variazioni non significative attribuibili ai vari rapporti.

#### 6.4 Efficiency

*The efficiency value of the gearbox can be estimated (**R = 0.97**) ignoring non-significant variations which can be attributed to the various ratios.*

#### 6.4 Wirkungsgrad

Der Wirkungsgrad der Getriebe kann mit ausreichender Annäherung ermittelt werden (**R = 0.97**), dabei können die unwesentlichen Veränderungen, die auf die verschiedenen Untersetzungsverhältnisse zurückzuführen sind, außer Acht gelassen werden.

#### 6.5 Giochi angolari

Bloccando l'albero di entrata, il gioco viene misurato sull'albero uscita ruotandolo nelle due direzioni ad applicando la coppia strettamente necessaria a creare il contatto tra i denti degli ingranaggi al max pari al 2% della coppia massima garantita dal riduttore.

Nella tabella seguente sono riportati i valori del gioco angolare (in minuti di angolo) per quanto riguarda il montaggio normale ed i valori ottenibili con una registrazione più precisa. Quest'ultima esecuzione è da utilizzare solo in caso di reale necessità in quanto potrebbe comportare un leggero aumento della rumorosità e rendere meno efficace l'azione dell'olio lubrificante.

#### 6.5 Angular backlash

*After having blocked the input shaft, the angular backlash can be measured on the output shaft by rotating it in both directions and applying the torque which is strictly necessary to create a contact between the teeth of the gears. The applied torque should be at most 2% of the max. torque guaranteed by the gearbox.*

*The following table reports the approximate value of the angular backlash (in minutes of arc) referred to standard mounting and the values to be obtained by a more precise adjustment. The latter solution should be adopted only in case of necessity because it may raise the noise level and lessen the action of the lubricant.*

#### 6.5 Winkelspiel

Nachdem die Antriebswelle blockiert worden ist, kann das Winkelspiel auf der Abtriebswelle gemessen werden. Indem die Abtriebswelle in beiden Richtungen verdreht und ein Drehmoment ausgeübt wird, da zu einem Kontakt zwischen den Zähnen führt. Das ausgeübte Drehmoment soll 2% des max. zulässigen Drehmoments ( $T_{2M}$ ) nicht übersteigen. Die folgende Tabelle zeigt die Näherungswerte des Winkelspiels (in Bogenminuten) für Standardmontage und Montage mit präziser Einstellung. Diese Lösung darf nur im Notfall angewendet werden, weil dabei der Geräuschpegel zunimmt und die Wirkung des Schmiermittels abnimmt.

Gioco angolare / Backlash / Winkelspiel (1')	
Montaggio normal Standard mounting Standardmontage	Montaggio con gioco ridotto Mounting with reduced backlash Montage mit reduziertem Winkelspiel
12/20	8

#### 6.6 Potenza termica

I valori delle potenze termiche,  $P_{10}$  (kW), relative alle diverse grandezze di rinvii angolari sono riportati nella tabella seguente.

#### 6.6 Thermal power

*The following table shows the values of thermal power  $P_{10}$  (kW) for each gearbox size.*

#### 6.6 Thermische Leistung

Die folgende Tabelle zeigt die Werte  $P_{10}$  der thermischen Leistung (kW) je nach Getriebegröße.

Tab. 2

$n_1$ [min <sup>-1</sup> ]	$P_{10}$ [kW] - Potenza Termica / Thermal power / Thermische Leistung				
	R19	R24	R28	R38	R48
1400	4.5	6.7	10.3	15.3	22.4

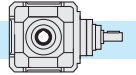

6.7 Dati tecnici

6.7 Technical data

6.7 Technische Daten

R	n <sub>1</sub> = 1400			RC - RF			RA	
	in	ir	n <sub>2</sub> rpm	T <sub>2</sub> Nm	P1 kW	FS'	T <sub>2M</sub> Nm	P kW
19	1	1	1400	12	1.8	3	35	5.5
	2.5	2.56	546	30	1.8	1.6	50	3
	5	4.90	285	48	1.5	1	48	1.5
	10	9.85	142	48	0.75	1	48	0.75
24	1	1	1400	26	4	2.7	73	11
	2.5	2.56	546	68	4	1.4	93	5.5
	5	4.90	285	97	3	1	97	3
	10	9.85	142	98	1.5	1	98	1.5
28	1	1	1400	61	9.2	2.4	146	22
	2.5	2.56	546	156	9.2	1.2	187	11
	5	4.90	285	179	5.5	1	179	5.5
	10	9.85	142	196	3	1	196	3

R	n <sub>1</sub> = 1400			RC - RF			RA	
	in	ir	n <sub>2</sub> rpm	T <sub>2</sub> Nm	P1 kW	FS'	T <sub>2M</sub> Nm	P kW
38	1	1	1400	146	22	2	291	45
	2.5	2.56	546	373	22	1	365	22
	5	4.90	285	357	11	1	350	11
	10	9.85	142	359	5.5	1	350	5.5
48	1	1	1400	199	30	3	596	90
	2.5	2.56	546	509	30	1.5	763	45
	5	4.90	285	715	22	1	715	22
	10	9.85	142	717	11	1	717	11

Verifica termica necessaria / Thermal rating needed / Thermische - Prüfung erforderlich

R	i	IEC									
		63	71	80	90	100	112	132	160	180	200
19	1	RC - RF									
	2.5-5-10	RC - RF									
24	1	RC - RF									
	2.5-5-10	RC - RF									
28	1	RC - RF									
	2.5-5-10	RC - RF									
38	1	RC - RF									
	2.5-5-10	RC - RF									
48	1	RC - RF									
	2.5-5-10	RC - RF									

6.8 Senso di rotazione alberi

6.8 Shaft Rotation Direction

6.8 Wellendrehrrichtungen

s.e. = Entrata supplementare / Additional input / Zusatzantrieb

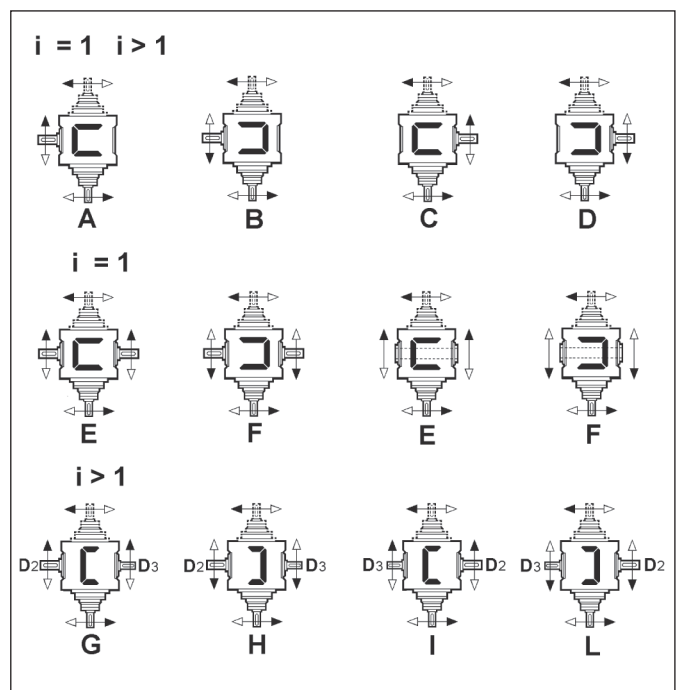
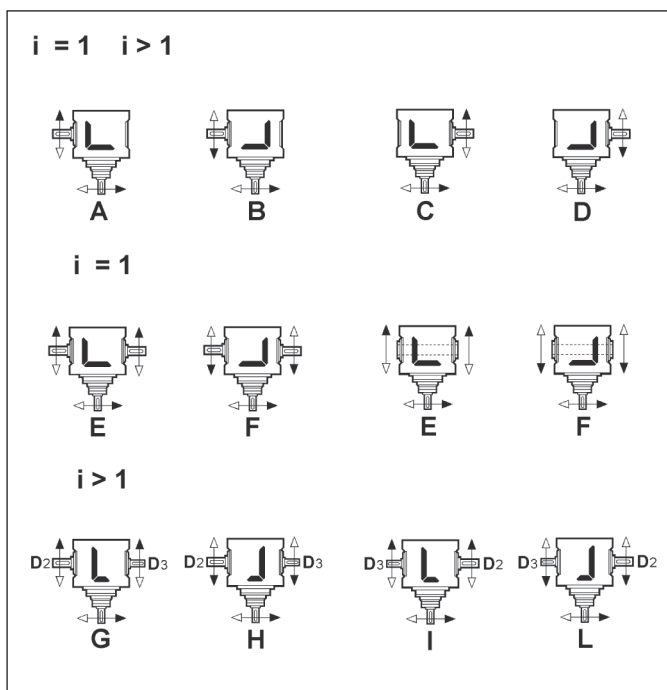

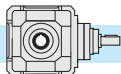











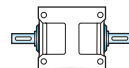





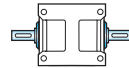

6.9 **Momenti d'inerzia** [Kg·cm<sup>2</sup>]  
(riferiti all'albero veloce in entrata)

6.9 **Moments of inertia** [Kg·cm<sup>2</sup>]  
(referred to input shaft)

6.9 **Trägheitsmoment** [Kg·cm<sup>2</sup>]  
(bez. Antriebswelle)

		$i_n$	RA 	RC 				RF 			
				IEC B5				IEC B5			
				63	71	80	90	63	71	80	90
<b>19</b>	<b>S</b> 	1	4.53	4.15	4.28	4.65	4.68	4.81	5.31	5.44	6.51
		2.5	0.88	0.93	1.07	1.45	1.50	1.13	1.15	1.82	2.89
		5	0.36	0.41	0.55	0.93	0.97	0.61	0.63	1.31	2.37
		10	0.19	0.22	0.36	0.74	0.79	0.44	0.46	1.14	2.20
	<b>B</b> 	1	4.57	4.19	4.33	4.70	4.73	4.84	5.34	5.48	6.55
		2.5	0.88	0.93	1.07	1.45	1.50	1.13	1.15	1.83	2.89
		5	0.36	0.41	0.55	0.93	0.97	0.61	0.63	1.31	2.37
		10	0.19	0.22	0.36	0.74	0.79	0.44	0.46	1.14	2.20
	<b>C</b> 	1	4.17	3.93	4.07	4.44	4.47	4.45	4.95	5.08	6.16

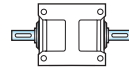
		$i_n$	RA 	RC 				RF 			
				IEC B5				IEC B5			
				71	80	90	110-112	71	80	90	110-112
<b>24</b>	<b>S</b> 	1	11.52	11.27	11.43	11.80	12.62	13.36	13.69	13.61	15.39
		2.5	2.46	2.87	3.04	3.42	4.26	3.32	3.46	4.63	6.80
		5	1.08	1.45	1.62	2.00	2.84	1.94	2.07	3.25	5.42
		10	0.64	0.97	1.14	1.52	2.36	1.49	1.63	2.80	4.97
	<b>B</b> 	1	11.60	11.38	11.54	11.91	12.73	13.45	13.77	13.70	15.47
		2.5	2.47	2.88	3.05	3.43	4.27	3.33	3.47	4.64	6.81
		5	1.08	1.45	1.62	2.00	2.84	1.94	2.07	3.25	5.42
		10	0.64	0.97	1.14	1.52	2.36	1.49	1.63	2.80	4.97
	<b>C</b> 	1	10.48	10.62	10.78	11.14	11.97	12.32	12.64	12.57	14.34



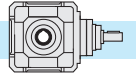



		$i_n$	RA 	RC 				RF 			
				IEC B5				IEC B5			
				80	90	110-112	132	80	90	110-112	132
<b>28</b>	<b>S</b> 	1	31.45	28.26	28.12	29.01	32.12	35.79	35.74	35.91	46.94
		2.5	7.02	7.95	7.82	8.78	11.92	9.36	9.29	11.60	25.60
		5	3.22	4.06	3.93	4.88	8.02	5.55	5.48	7.80	21.79
		10	1.75	2.46	2.33	3.28	6.42	4.08	4.01	6.33	20.32
	<b>B</b> 	1	31.87	28.73	28.59	29.47	32.59	36.21	36.16	36.34	47.36
		2.5	7.05	7.98	7.85	8.80	11.94	9.38	9.31	11.63	25.62
		5	3.23	4.06	3.93	4.88	8.02	5.56	5.49	7.81	21.80
		10	1.75	2.46	2.33	3.28	6.42	4.08	4.01	6.33	20.33
	<b>C</b> 	1	28.36	26.95	26.82	27.70	30.81	32.69	32.65	32.82	43.84









6.9 **Momenti d'inerzia** [Kg·cm<sup>2</sup>]  
(riferiti all'albero veloce in entrata)

6.9 **Moments of inertia** [Kg·cm<sup>2</sup>]  
(referred to input shaft)

6.9 **Trägheitsmoment** [Kg·cm<sup>2</sup>]  
(bez. Antriebswelle)

		$i_n$													
				IEC B5					IEC B5						
				80	90	110-112	132	160	180	80	90	110-112	132	160	180
<b>38</b>		1	82.73	73.23	73.09	73.20	76.34	80.53	83.31	99.45	99.4	100.4	101.8	103.9	149.0
		2.5	20.67	21.83	21.70	21.84	25.04	29.46	32.48	22.87	25.25	25.43	40.29	42.47	87.73
		5	7.92	8.95	8.82	8.95	12.15	16.58	19.60	10.12	12.50	12.67	27.53	29.71	74.98
		10	4.17	4.83	4.70	4.84	8.04	12.46	15.48	6.36	8.75	8.92	23.78	25.96	71.23
		1	84.86	75.54	75.40	75.50	78.65	82.84	85.62	99.45	101.49	102.53	103.90	106.08	151.18
		2.5	20.74	21.90	21.77	21.91	25.11	29.53	32.55	22.94	25.32	25.49	40.35	42.53	87.80
		5	7.94	8.96	8.83	8.97	12.17	16.60	19.61	10.13	12.52	12.69	27.55	29.73	75.00
		10	4.17	4.83	4.70	4.84	8.04	12.47	15.48	6.37	8.75	8.93	23.79	25.97	71.23
		1	76.44	68.61	68.47	68.57	71.71	75.91	78.68	93.25	93.17	94.21	95.57	97.75	142.86

		$i_n$											
				IEC B5					IEC B5				
				110-112	132	160	180	200	110-112	132	160	180	200
<b>48</b>		1	177.58	177.7	183.4	182.4	185.3	195.7	233.7	238.9	246.9	244.9	241.4
		2.5	61.86	64.36	70.04	69.04	71.95	82.34	81.5	82.8	85.0	134.1	130.7
		5	24.06	26.80	32.48	31.48	34.39	44.78	43.7	45.0	47.2	96.3	92.9
		10	11.50	13.77	19.45	18.45	21.36	31.75	31.1	32.5	34.7	83.8	80.3
		1	183.40	183.5	189.2	188.2	191.1	201.5	239.5	244.7	252.7	250.7	247.2
		2.5	62.11	64.70	70.38	69.38	72.29	82.68	81.7	83.1	85.3	134.4	130.9
		5	24.13	26.89	32.57	31.57	34.48	44.87	43.7	45.1	47.3	96.4	92.9
		10	11.52	13.80	19.48	18.48	21.39	31.77	31.1	32.5	34.7	83.8	80.3
		1	160.10	160.8	166.5	165.5	168.4	178.8	-	221.4	229.4	227.4	223.9



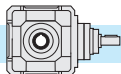

6.10 Dimensioni

6.10 Dimensions

6.10 Abmessungen

		RA...- RC...- RF...					
		19	24	28	38	48	
A	i = 1	112	142	180	224	280	
a		80	100	130	160	190	
B		128	146	175	204	230	
b		110	125	145	175	200	
C2		130	150	180	210	240	
D2 <sub>h6</sub>		19	24	28	38	48	
d2		M8	M8	M8	M10	M12	
M2		21.5	27	31	41	51.5	
N2		6	8	8	10	14	
F		7	9	11	13	15	
H		56	71	90	112	140	
L2		40	50	60	80	110	
Z		7	9	10	13	15	
D3 <sub>h6</sub>		i = 1	19	24	28	38	48
d3			M8	M8	M8	M10	M12
L3	40		50	60	80	110	
M3	21.5		27	31	41	51.5	
N3	6		8	8	10	14	
D4 <sub>H7</sub>	20		25	30	40	50	
M4	22.8		28.3	33.3	43.3	53.8	
N4	6		8	8	12	14	
D3 <sub>h6</sub>	i > 1	14	19	24	28	38	
d3		M6	M8	M8	M10	M10	
L3		30	40	50	60	80	
M3		16	21.5	27	31	41	
N3		5	6	8	8	10	

		RA				
		19	24	28	38	48
h	i = 1	101	120	147	170	207.5
D1 <sub>h6</sub>		19	24	28	38	48
d1		M8	M8	M8	M10	M12
M1		21.5	27	31	41	51.5
N1		6	8	8	10	14
h	i > 1	110	130	160	190	237.5
D1 <sub>h6</sub>		14	19	24	28	38
d1		M6	M8	M8	M8	M10
M1		16	21.5	27	31	41
N1		5	6	8	8	10
L1	i = 1	30	40	50	60	80
X	i > 1	90	110	130	150	175
kg		8.5	14	23	38	62
		RC...- RF...				
kg		11.5	19	33	55	82



		RC...								
		19				24				
IEC		63 B5	71 B5	80/90 B5	80 B14	71 B5	80 B5	90 B5	90* B14	100/112 B5
Q		—	—	—	—	—	—	—	120	—
Y		140	160	200	120	160	200	200	146	250
P	i = 1	104	111	131	131	128	148	148	148	158
P	i > 1	113	120	140	140	138	158	158	158	168



		RC...											
		28			38				48				
IEC		80/90 B5	100/112 B5	132 B5	80 B5	90 B5	100/112 B5	132 B5	160/180 B5	100/112 B5	132 B5	160/180 B5	200 B5
Y		200	250	300	200	200	250	300	350	250	300	350	400
P	i = 1	171	181	203	184	184	194	216	246	220	240	270	270
P	i > 1	184	194	216	204	204	214	236	266	250 (i=2.5 - 5) 260 (i=10)	270 (i=2.5 - 5) 280 (i=10)	300 (i=2.5 - 5) 310 (i=10)	

\* Flange quadrate / Square flanges / Viereckige Flansche

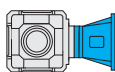

		RF...																
		19			24			28			38				48			
IEC		63 B5	71 B5	80/90 B5	71 B5	80/90 B5	100/112 B5	80/90 B5	100/112 B5	132 B5	80/90 B5	100/112 B5	132 B5	160/180 B5	100/112 B5	132 B5	160/180 B5	200 B5
Y		140	160	200	160	200	250	200	250	300	200	250	300	350	250	300	350	400
P	i = 1	158	165	186	194	215	225	252	262	283	285	295	316	346	354	373	405	405
P	i > 1	167	174	195	204	225	235	265	275	296	305	315	336	366	384	403	435	435

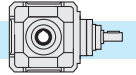

Tipo entrata / Input type / Antriebsart

Tipo uscita / Output type / Ausgang Typ

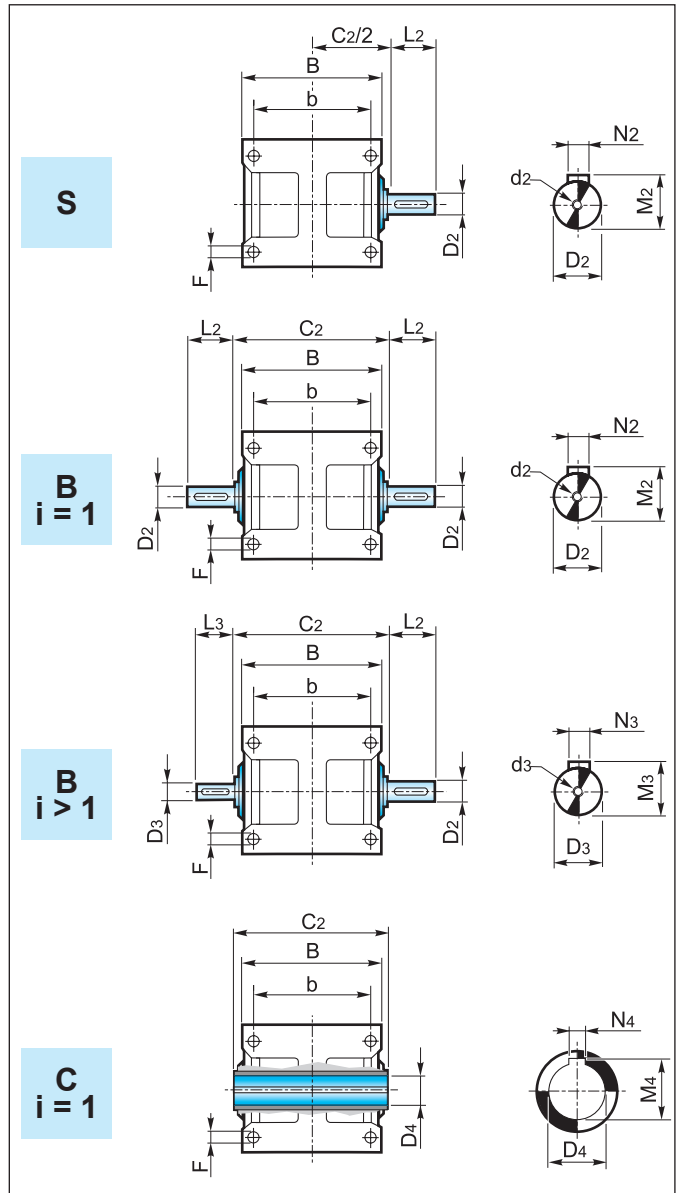
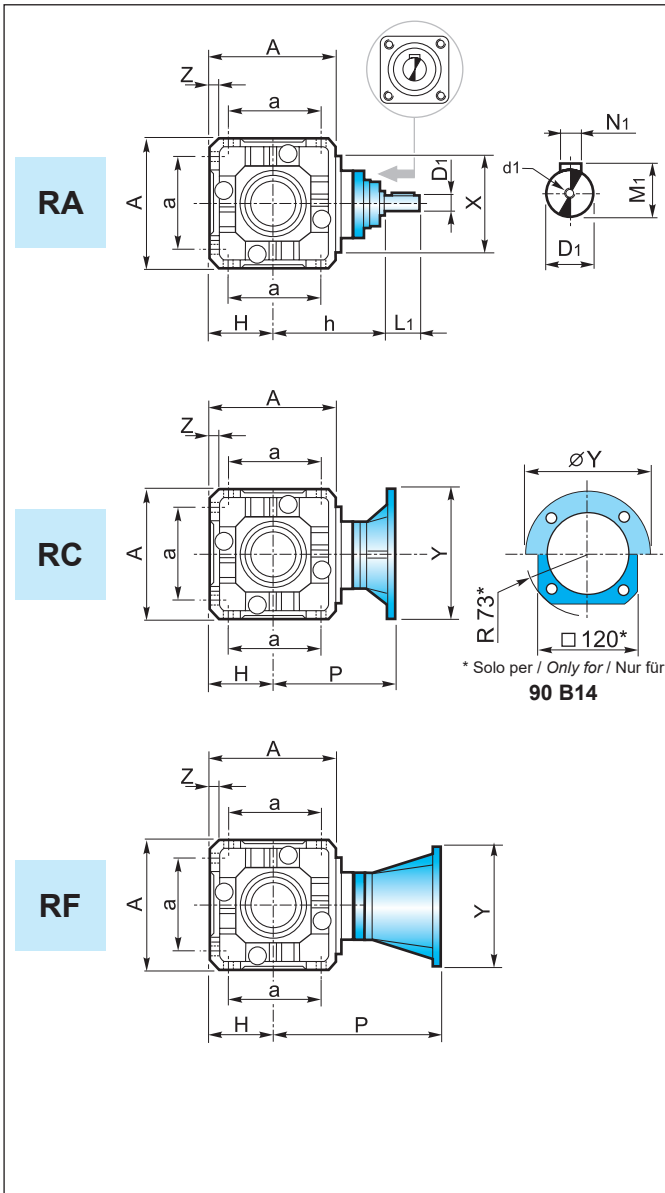

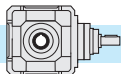

### 6.11 Accessori

### 6.11 Accessories

### 6.11 Zubehör

#### Flangia uscita

#### Output flange

#### Abtriebsflansch

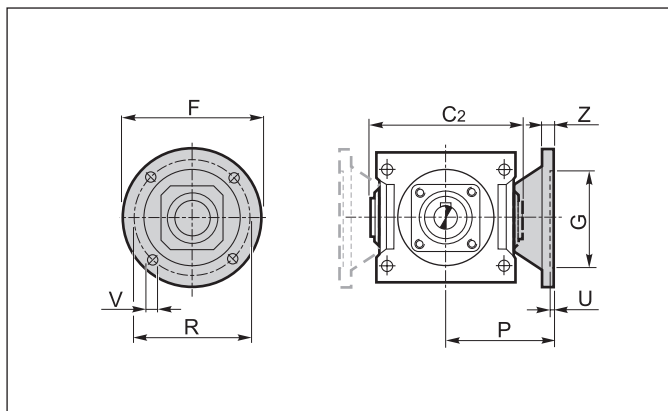

	R				
	19	24	28	38	48
<b>C2</b>	130	150	180	210	240
<b>F</b>	140	160	200	250	250
<b>G<sub>F7</sub></b>	95	110	130	180	180
<b>P</b>	86	100	120	145	175
<b>R</b>	115	130	165	215	215
<b>U</b>	3.5	4	4.5	5	5
<b>V</b>	9	11	13	15	15
<b>Z</b>	10	12.5	16	20	20

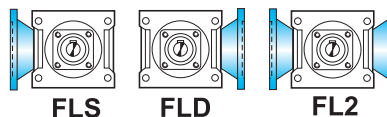

### 6.12 Lubrificazione

### 6.12 Lubrication

### 6.12 Schmierung

I rinvii angolari sono forniti predisposti per lubrificazione a olio e muniti dei tappi di carico, livello e scarico olio.

Si raccomanda di precisare sempre la posizione di montaggio desiderata in fase di ordine.

Il rinvio grandezza 19 viene fornito lubrificato a vita e non è previsto il tappo di sfiato.

*Right angle gearboxes require oil lubrication and are equipped with filler, level and drain plugs.*

*The mounting position should always be specified when ordering the gearbox.*

*The right angle gearbox size 19 is lubricated for life and without breather plug.*

Die Winkelgetriebe sind für die Ölschmierung mit Einfüll-, Ölstand- und Ablassstopfen versehen.

Bei der Bestellung ist immer die gewünschte Montageposition anzugeben.

Das Winkelgetriebe Größe 19 ist Lebensdauer geschmiert und ohne Entlüftungsschraube.

#### Posizione di montaggio e quantità di lubrificante (litri)

#### Mounting positions and lubricant quantity (litres)

#### Montageposition und Ölmenge (Liter)

I quantitativi di olio riportati nelle varie tabelle sono indicativi e riferiti alle posizioni di lavoro indicate e considerando le condizioni di funzionamento a temperatura ambiente e velocità in ingresso di 1400 min<sup>-1</sup>. Per condizioni di lavoro diverse da quelle sopra riportate contattare il servizio tecnico.

*The oil quantities stated in the tables are approximate values and refer to the indicated working positions, considering operating conditions at ambient temperature and an input speed of 1400 min<sup>-1</sup>. Should the operating conditions be different, please contact the technical service.*

Die in der Tabellen angegebenen Daten sind Richtwerte. Die Ölmenge beziehen sich auf die angegebene Betriebsposition. Dabei werden Betrieb bei Umgebungtemperatur und Antriebsdrehzahl von 1400 min<sup>-1</sup> berücksichtigt. Falls die Betriebsbedingungen anders sind, dann ist das technische Büro zu befragen.

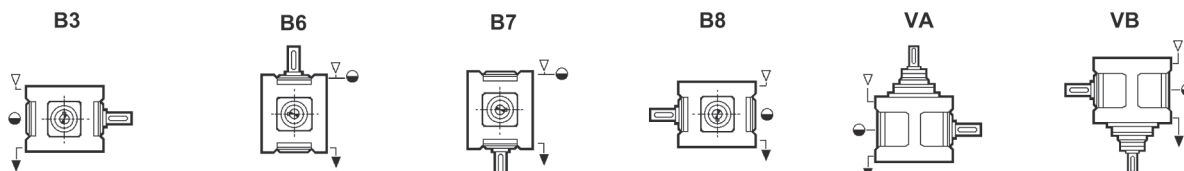

R	B3	B6	B7	B8	VA	VB
<b>19</b>	0.2	0.2	0.2	0.2	0.2	0.2
<b>24</b>	0.4	0.8	0.8	0.4	0.6	0.5
<b>28</b>	0.9	1.6	1.6	0.8	0.9	0.8
<b>38</b>	1.6	3.0	3.0	2.0	2.7	2.7
<b>48</b>	4.0	5.6	5.6	4.0	5.6	5.6

#### Posizione morsettiera

#### Terminal board position

#### Lage des Klemmenkastens

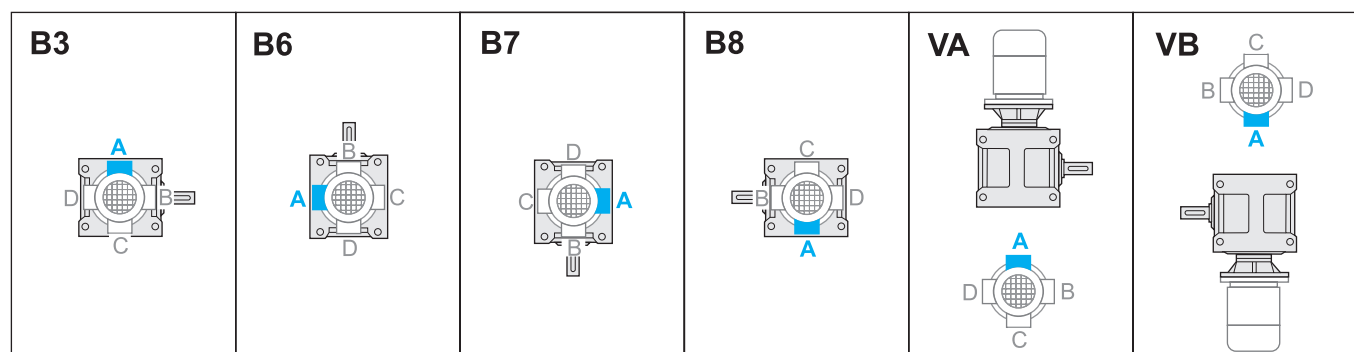

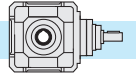

### 6.13 Carichi radiali e assiali (N)

Le trasmissioni effettuate tramite pignoni per catena, ruote dentate o pulegge generano delle forze radiali ( $F_R$ ) sugli alberi dei riduttori. L'entità di tali forze può essere calcolata con la formula:

### 6.13 Radial and axial loads (N)

Transmissions implemented by means of chain pinions, wheels or pulleys generate radial forces ( $F_R$ ) on the gear unit shafts. The entity of these forces may be calculated using the following formula:

### 6.13 Radial- und Axialbelastungen (N)

Antriebe mit Kettenritzel, Zahnrädern oder Riemscheiben erzeugen radiale Kräfte ( $F_R$ ) an den Wellen der Untersetzungsgetriebe. Die Größe dieser Kraft kann nach folgender Formel berechnet werden:

$$F_R = \frac{K_R \cdot T}{d} \text{ [N]}$$

dove:

T = Momento torcente [Nm]  
d = Diametro pignone o puleggia [mm]

$K_R$  = 2000 per pignone per catena  
= 2500 per ruote dentate  
= 3000 per puleggia con cinghie a V

where:

T = torque [Nm]  
d = pinion or pulley diameter [mm]

$K_R$  = 2000 for chain pinion  
= 2500 for wheel  
= 3000 for V-belt pulley

dabei ist:

T = Drehmoment [Nm]  
d = Kettenritzel- bzw. Riemscheiben durchmesser [mm]

$K_R$  = 2000 bei Kettenritzel  
= 2500 bei Zahnrad  
= 3000 bei Riemscheibe mit Keilriemen

I valori dei carichi radiali e assiali generati dall'applicazione debbono essere sempre minori o uguali a quelli ammissibili indicati nelle tabelle.

The values of the radial and axial loads generated by the application must always be lower than or equal to the admissible values reported in the tables.

Die Werte der Radial- und Axialbelastungen, die durch die Anwendung hervorgerufen werden, dürfen nicht über den in den Tabellen angegebenen zulässigen Werten liegen.

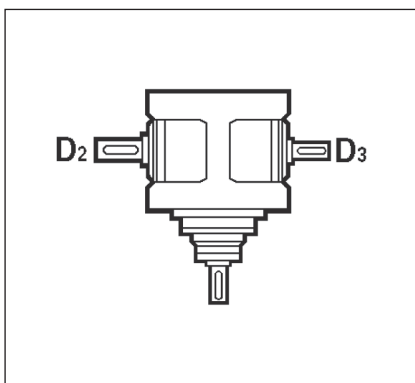
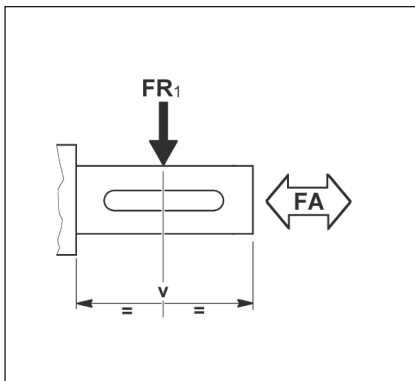

$i_n$	Albero Shaft Welle	R									
		19	24	28	38	48					
<b>ALBERO ENTRATA / INPUT SHAFT / ANTRIEBSWELLE (<math>n_1 = 1400 \text{ min}^{-1}</math>)</b>											
		$Fr_1$	$Fa_1$	$Fr_1$	$Fa_1$	$Fr_1$	$Fa_1$	$Fr_1$	$Fa_1$	$Fr_1$	$Fa_1$
Tutti All Alle	Tutti All Alle	400	80	630	125	1000	200	1600	320	2500	500
<b>ALBERO USCITA / OUTPUT SHAFT / ABTRIEBSWELLE (<math>n_1 = 1400 \text{ min}^{-1}</math>)</b>											
		$Fr_2$	$Fa_2$	$Fr_2$	$Fa_2$	$Fr_2$	$Fa_2$	$Fr_2$	$Fa_2$	$Fr_2$	$Fa_2$
1	Tutti All Alle	800	160	1250	250	2000	400	3150	630	5000	1000
2.5	D2	1000	200	1600	320	2500	500	4000	800	6300	1260
	D3	630	130	1000	200	1600	320	2500	500	4000	800
5	D2	1250	250	2000	400	3150	630	5000	1000	8000	1600
	D3	800	160	1250	250	2000	400	3150	630	5000	1000
10	D2	1600	320	2500	500	4000	800	6300	1260	10000	2000
	D3	1000	200	1600	320	2500	500	4000	800	6300	1260

I carichi radiali indicati nelle tabelle si intendono applicati a metà della sporgenza dell'albero e sono riferiti ai riduttori operanti con fattore di servizio 1.

The radial loads reported in the table are considered to be applied at the half-way point of the shaft projection and refer to gear units operating with service factor 1.

Die Radialbelastungen, die in den Tabellen angegeben werden, gelten für Ansatzpunkte in der Mitte des herausragenden Wellenteils und für Getriebe mit Betriebsfaktor 1.

Nel caso di alberi bisporgenti il valore del carico applicabile a ciascuna estremità è uguale ai 2/3 del valore di tabella, purché i carichi applicati siano uguali di intensità e direzione ed agiscano nello stesso senso. Diversamente contattare il servizio tecnico.

With regard to double-projecting shafts, the load applicable at each end is 2/3 of the value given in the table, on condition that the applied loads feature same intensity and direction and that they act in the same direction. Otherwise please contact the technical department.

Bei doppelseitigen Wellen ist die Belastung, die an jedem Ende anwendbar ist, 2/3 des in der Tabelle angegebenen Wertes unter der Bedingung, dass sie in derselben Stärke und Richtung wirken. Andernfalls muß mit dem technischen Büro Rücksprache gehalten werden.

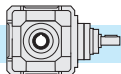

**RA - RC - RF (in = 1)**

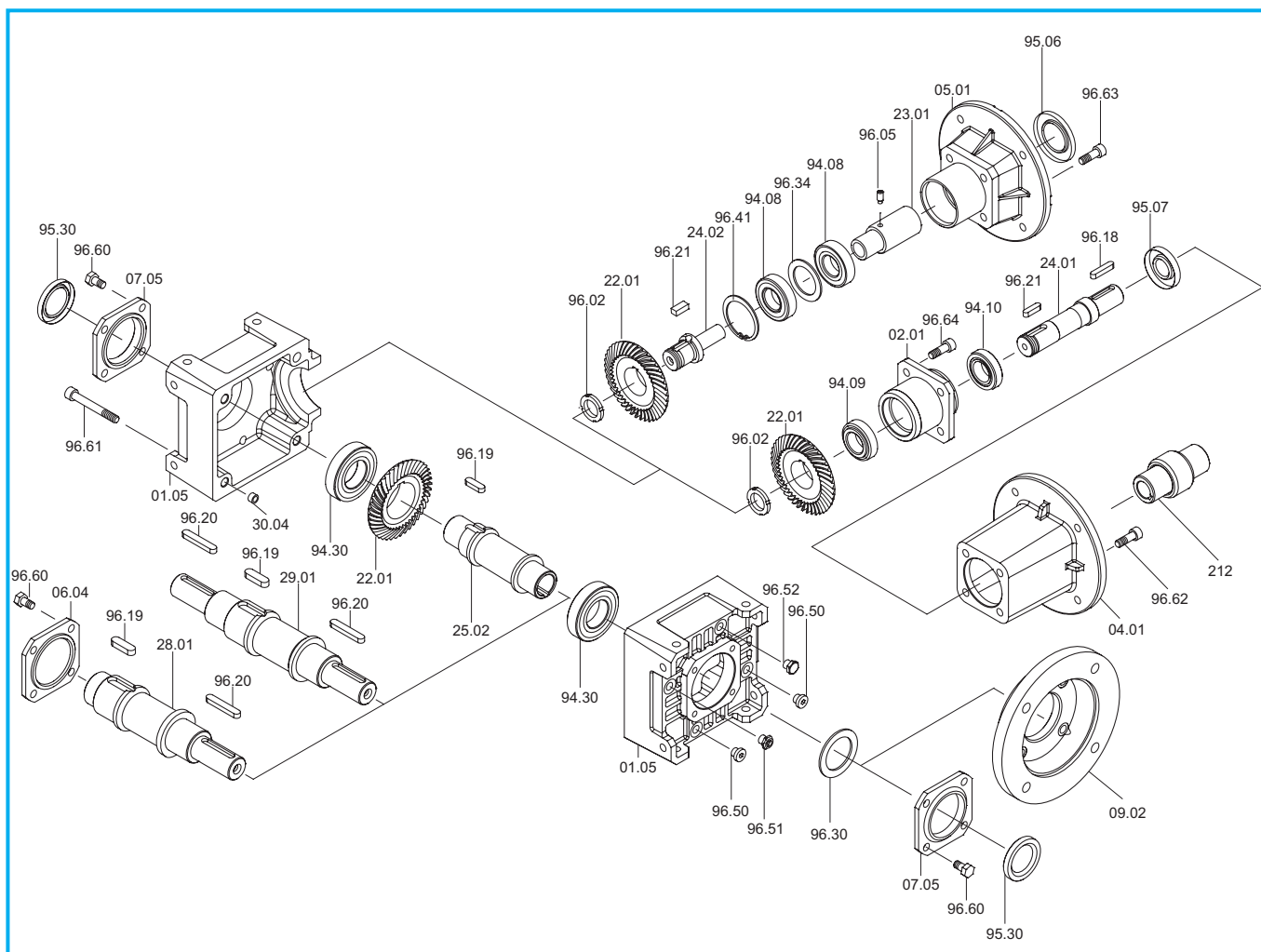

RA - RC - RF in = 1:1	Cuscinetti/ Bearings / Lager			Anelli di tenuta / Oilseals / Öldichtungen			
	RA - RC - RF	RA - RF	RC	RA - RC - RF	RC	RA - RF	
	94.30	94.10 - 94.09	94.08	95.30	IEC	95.06	
<b>19</b>	6206 30/62/16	30203 17/40/13.25	7203 17/40/12	30/47/7	95.06	20/40/7	
					63		25/52/7
					71		30/52/7
					80		35/52/7
<b>24</b>	6207 35/72/17	32005 25/47/15	7205 25/52/15	35/52/7	90	30/47/7	
					71 - 80		35/62/7
					100 - 112		45/62/8
<b>28</b>	6208 40/80/18	32006 30/55/17	7206 30/62/16	40/62/8	80 - 90	35/58/10	
					100 - 112		45/72/8
					132		55/72/8
					160		60/80/8
<b>38</b>	30211 55/100/22.75	32007 35/62/18	7207 35/72/17	55/72/10	180	40/62/7	
					80 - 90		45/80/10
					100 - 112		45/80/10
					132		55/80/10
<b>48</b>	30213 65/120/24.75	33109 45/80/26	7209 45/85/19	65/90/10	160	55/80/8	
					180		65/80/8
					100 - 112		55/100/13
					132 - 160		60/100/10
					180	65/100/10	
					200	75/100/10	



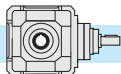

**RA - RC - RF (in = 1) s.e.**

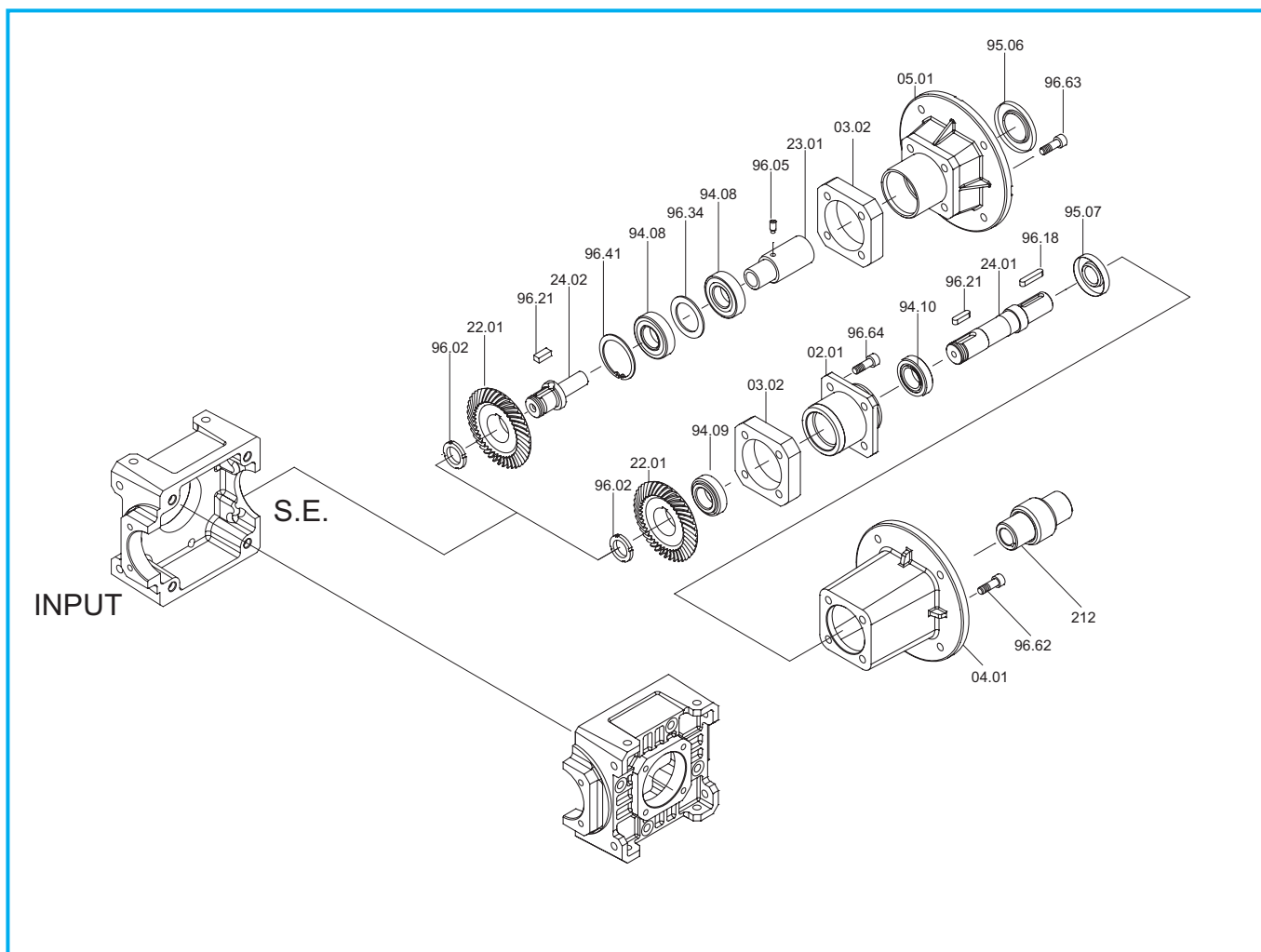

RA - RC - RF in = 1:1 S.E	Cuscinetti/ Bearings / Lager		Anelli di tenuta / Oilseals / Öldichtungen		
	RA - RF	RC	RC		RA - RF
	94.10 - 94.09	94.08	IEC	95.06	95.07
<b>19</b>	<b>32003</b> 17/40/13.25	<b>7203</b> 17/40/12	63	<b>25/52/7</b>	<b>20/40/7</b>
			71	<b>30/52/7</b>	
			80	<b>35/52/7</b>	
			90	<b>37/52/8</b>	
<b>24</b>	<b>32005</b> 25/47/15	<b>7205</b> 25/52/15	71 - 80	<b>35/62/7</b>	<b>30/47/7</b>
			90	<b>40/62/7</b>	
			100 - 112	<b>45/62/8</b>	
<b>28</b>	<b>32006</b> 30/55/17	<b>7206</b> 30/62/16	80 - 90	<b>40/72/7</b>	<b>35/58/10</b>
			100 - 112	<b>45/72/8</b>	
			132	<b>55/72/8</b>	
			80 - 90	<b>45/80/10</b>	
<b>38</b>	<b>32007</b> 35/62/18	<b>7207</b> 35/72/17	100 - 112	<b>45/80/10</b>	<b>40/62/7</b>
			132	<b>55/80/10</b>	
			160	<b>60/80/8</b>	
			180	<b>65/80/8</b>	
<b>48</b>	<b>33109</b> 45/80/26	<b>7209</b> 45/85/19	100 - 112	<b>55/100/13</b>	<b>55/80/8</b>
			132 - 160	<b>60/100/10</b>	
			180	<b>65/100/10</b>	
			200	<b>75/100/10</b>	





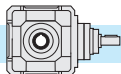

In fase di ordine delle parti di ricambio, specificare sempre n° particolare (vedi disegno esploso), data (1), n° codice (2) e n° variante (3). (Vedi targhetta).

*When ordering a spare part, the spare part number (see exploded technical drawing), the date (1), the code number (2) and the variant number (3) should always be reported. (See plate)*

Bei der Bestellung von Ersatzteilen sind Ersatzteilnummer (s. Explosionszeichnung), Datum (1), Artikelnummer (2) und Variantennummer (3) anzugeben. (s. Schild)

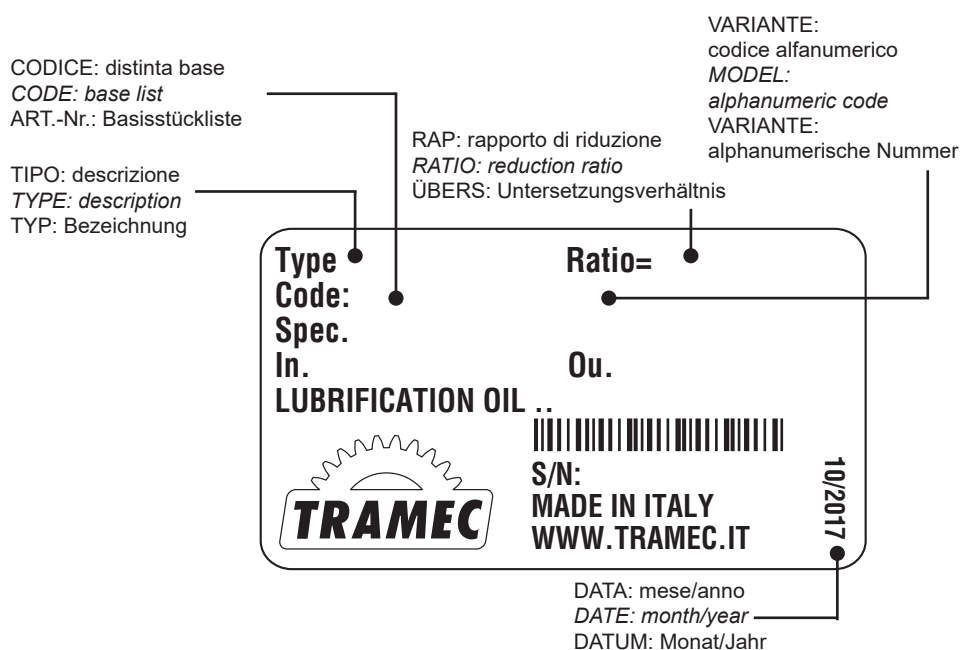

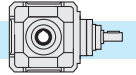

**7.0 RINVII ANGOLARI L      RIGHT ANGLE GEARBOX L      WINKELGETRIEBE L**

7.1	Caratteristiche	<i>Characteristics</i>	Merkmale	112
7.2	Designazione	<i>Designation</i>	Bezeichnung	113
7.3	Velocità in entrata	<i>Input speed</i>	Antriebsdrehzahl	113
7.4	Rendimento	<i>Efficiency</i>	Wirkungsgrad	114
7.5	Giochi angolari	<i>Angular backlash</i>	Winkelspiel	114
7.6	Potenza termica	<i>Thermal power</i>	Thermische Leistung	114
7.7	Dati tecnici	<i>Technical data</i>	Technische Daten	115
7.8	Senso di rotazione alberi	<i>Direction of shaft rotation</i>	Drehrichtungen der Wellen	115
7.9	Momenti d'inerzia	<i>Moments of inertia</i>	Trägheitsmoment	116
7.10	Dimensioni	<i>Dimensions</i>	Abmessungen	118
7.11	Accessori	<i>Accessories</i>	Zubehör	120
7.12	Lubrificazione	<i>Lubrication</i>	Schmierung	120
7.13	Carichi radiali e assiali (N)	<i>Radial and axial loads (N)</i>	Radial- und Axialbelastungen (N)	121
7.14	Lista parti di ricambio	<i>Spare parts list</i>	Ersatzteilliste	122

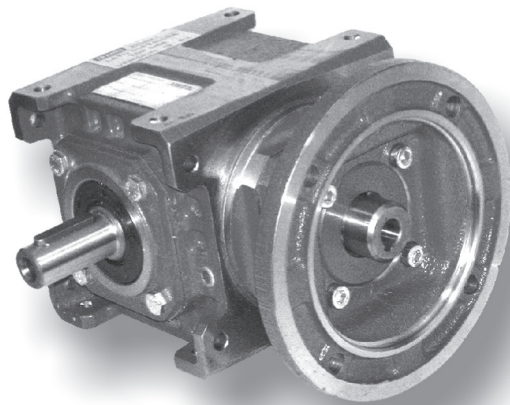

**LC..**

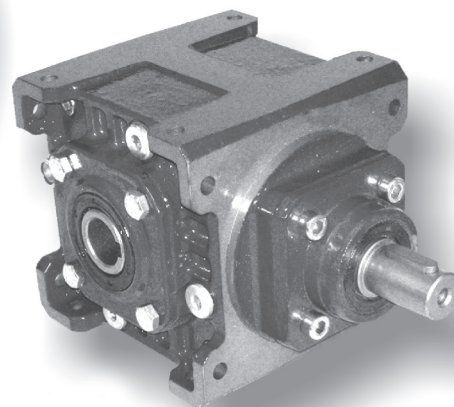

**LA..**

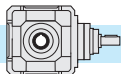

## 7.1 Caratteristiche

- Costruiti in 5 grandezze con tre tipi di albero uscita: cavo, sporgente, bisporgente. E' possibile inoltre disporre di un ulteriore albero di uscita opposto a quello di entrata.
- Sono previsti tre tipi di entrata: con albero sporgente, con predisposizione attacco motore (campana e giunto) e predisposizione attacco motore COMPACTA.
- Il corpo riduttore in ghisa meccanica EN GJL 200 UNI EN 1561 abbondantemente nervato all'interno e all'esterno per garantire la rigidità, è lavorato su tutti i piani per consentire un facile posizionamento; inoltre un'unica camera di lubrificazione garantisce una maggiore dissipazione termica e una migliore lubrificazione di tutti gli organi interni.
- Il cinematismo di questi rinvii è costituito da una coppia di ingranaggi conici a dentatura spirooidale GLEASON con profilo accuratamente rodato, in acciaio 16CrNi4 o 18NiCrMo5.
- L'utilizzo di cuscinetti di qualità su tutti gli assi, consente al riduttore di ottenere durate molto elevate e di sopportare elevati carichi radiali e assiali.
- Il corpo riduttore, le flange, le campane ed i coperchi vengono verniciati esternamente di colore BLU RAL 5010.

## 7.1 Characteristics

- *Built in 5 sizes with three types of output shaft : hollow, projecting or double-extended. Moreover, an additional output shaft can be installed opposite to the input shaft.*
- *Three input types are available : with projecting input shaft, with pre-engineered motor coupling (bell and joint) and pre-engineered COMPACT motor coupling.*
- *Gear unit body in engineering cast iron, EN GJL 200 UNI EN 1561 ribbed internally and externally to guarantee rigidity and machined on all surfaces for easy positioning. The single lubrication chamber guarantees improved heat dissipation and better lubrication of all the internal components.*
- *The mechanism of these gearboxes consists of two GLEASON spiral bevel gears with precision lapped profile, 16CrNi4 or 18NiCrMo5 made of steel.*
- *The use of high quality bearings on all the axis ensures long life to the gearbox and allows very high radial and axial loads.*
- *Gearbox housing, flanges, bells and covers are externally painted with BLUE RAL 5010.*

## 7.1 Merkmale

- Die Getriebe sind in 5 Baugrößen und 3 Abtriebsvarianten (Hohlwelle, einseitige Abtriebswelle und doppelseitige Abtriebswelle) erhältlich. Eine zusätzliche Abtriebswelle kann gegenüber dem Eintrieb montiert werden
- Drei Antriebsarten (Getriebeeingang) sind lieferbar: Eingangswelle, Motoranbau mit Glocke und Kupplung, Motor Direktanbau.
- Das Getriebegehäuse aus Maschinenguß EN GJL 200 UNI EN 1561 ist sowohl innen als auch außen mit Rippen versehen, versehen, die die Steifheit leisten; die Bearbeitung aller Flächen ermöglicht eine leichte Positionierung; eine einzige Schmierkammer gewährleistet eine höhere Wärmedissipation und eine bessere Schmierung aller inneren Elemente.
- Die Vorgelege bestehen aus einem spiralverzahnten GLEASON-Kegelradpaar mit sorgfältig eingelaufenen Profil aus 16CrNi4- oder 18NiCrMo5-Stahl.
- An allen Achsen werden Qualitäts-Lager eingebaut. Diese gewährleisten eine hohe Lebensdauer und das Aushalten sehr hoher äußerer Radial- und Axialbelastungen.
- Getriebegehäuse, Flansche, Glocken und Deckel werden in BLAU RAL 5010 lackiert.

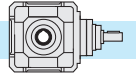

## 7.2 Designazione

## 7.2 Designation

## 7.2 Bezeichnung

Macchina Machine Maschine	Tipo entrata Input type Antriebsart	Grandezza Size Größe	Rotismo Gearing Räderwerk	Tipo uscita Output type Ausgang Typ	Rapporto rid. Ratio Untersetzungsverhältnis	Predisposizione att. mot. Motor coupling Motoranschluss	Entrata supplementare Additional input Zusatzantrieb	Rotazione alberi Shafts rotation Wellendrehrichtungen	Posizione di montaggio Mounting position Baulage	Flangia uscita Output flange Abtriebsflansch
<b>L</b>	<b>A</b>	<b>28</b>	<b>A</b>	<b>C</b>	<b>2</b>	<b>P.A.M.</b>	<b>S.e.A.</b>	<b>B</b>	<b>B3</b>	<b>FLD</b>
Rinvii angolari Right angle gearboxes Winkelgetriebe	A C F	19 24 28 38 48	A	S B C	$i_n =$ 1 2 3	63 ÷ 200	A C F	A B C D E F	B3 B6 B7 B8 VA VB	FLS FLD FL2

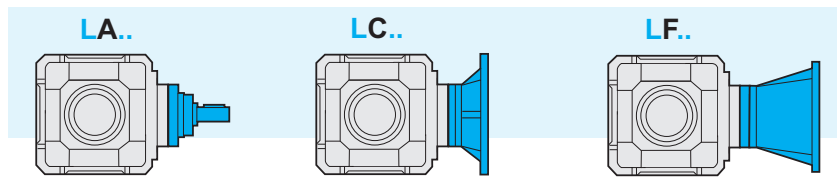

## 7.3 Velocità in entrata

Tutte le prestazioni dei riduttori sono calcolate in base ad una velocità in entrata di 1400 min<sup>-1</sup>.

La massima velocità ammessa in entrata è pari a 1400 min<sup>-1</sup>. Nel caso in cui tale limite debba essere superato contattare il servizio tecnico.

Nella tabella sottostante riportiamo i coefficienti correttivi della potenza in entrata P alle varie velocità riferita ad Fs = 1

## 7.3 Input speed

All calculations of gear unit performance specifications are based on an input speed of 1400 min<sup>-1</sup>.

1400 min<sup>-1</sup> is the max. allowed input speed. For higher speed pls contact the technical service.

The table below shows the input power P corrective coefficients at the various speeds, with Fs = 1.

## 7.3 Antriebsdrehzahl

Bei der Berechnung der Getriebeleistungen wurde eine Antriebsdrehzahl von 1400 min<sup>-1</sup> zugrunde gelegt.

1400 min<sup>-1</sup> ist die max. zulässige Antriebsdrehzahl. Falls die verlangte Antriebsdrehzahl höher ist, muss mit dem technischen Büro Rücksprache gehalten werden.

In der folgenden Tabelle finden Sie die Korrektorkoeffizienten für die Antriebsleistung P bei den verschiedenen Drehzahlen, bezogen auf Fs = 1.

Tab. 1

n <sub>1</sub> [min <sup>-1</sup> ]	1400	900	700	500
P <sub>c</sub> (kW)	P x 1	P x 0.7	P x 0.56	P x 0.42

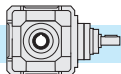

#### 7.4 Rendimento

Il valore del rendimento dei riduttori può essere stimato con sufficiente approssimazione (**R=0.97**), trascurando le variazioni non significative attribuibili ai vari rapporti.

#### 7.4 Efficiency

*The efficiency value of the gearbox can be estimated (**R = 0.97**) ignoring non-significant variations which can be attributed to the various ratios.*

#### 7.4 Wirkungsgrad

Der Wirkungsgrad der Getriebe kann mit ausreichender Annäherung ermittelt werden (**R = 0.97**), dabei können die unwesentlichen Veränderungen, die auf die verschiedenen Unteretzungsverhältnisse zurückzuführen sind, außer Acht gelassen werden.

#### 7.5 Giochi angolari

Bloccando l'albero di entrata, il gioco viene misurato sull'albero uscita ruotandolo nelle due direzioni ad applicando la coppia strettamente necessaria a creare il contatto tra i denti degli ingranaggi al max pari al 2% della coppia massima garantita dal riduttore.

Nella tabella seguente sono riportati i valori del gioco angolare (in minuti di angolo) per quanto riguarda il montaggio normale ed i valori ottenibili con una registrazione più precisa. Quest'ultima esecuzione è da utilizzare solo in caso di reale necessità in quanto potrebbe comportare un leggero aumento della rumorosità e rendere meno efficace l'azione dell'olio lubrificante.

#### 7.5 Angular backlash

*After having blocked the input shaft, the angular backlash can be measured on the output shaft by rotating it in both directions and applying the torque which is strictly necessary to create a contact between the teeth of the gears. The applied torque should be at most 2% of the max. torque guaranteed by the gearbox.*

*The following table reports the approximate value of the angular backlash (in minutes of arc) referred to standard mounting and the values to be obtained by a more precise adjustment. The latter solution should be adopted only in case of necessity because it may raise the noise level and lessen the action of the lubricant.*

#### 7.5 Winkelspiel

Nachdem die Antriebswelle blockiert worden ist, kann das Winkelspiel auf der Abtriebswelle gemessen werden. Indem die Abtriebswelle in beiden Richtungen verdreht und ein Drehmoment ausgeübt wird, da zu einem Kontakt zwischen den Zähnen führt. Das ausgeübte Drehmoment soll 2% des max. zulässigen Drehmoments ( $T_{2M}$ ) nicht übersteigen. Die folgende Tabelle zeigt die Näherungswerte des Winkelspiels (in Bogenminuten) für Standardmontage und Montage mit präziser Einstellung. Diese Lösung darf nur im Notfall angewendet werden, weil dabei der Geräuschpegel zunimmt und die Wirkung des Schmiermittels abnimmt.

Gioco angolare / Backlash / Winkelspiel (1')	
Montaggio normal Standard mounting Standardmontage	Montaggio con gioco ridotto Mounting with reduced backlash Montage mit reduziertem Winkelspiel
12/20	8

#### 7.6 Potenza termica

I valori delle potenze termiche,  $P_{10}$  (kW), relative alle diverse grandezze di rinvii angolari sono riportati nella tabella seguente.

#### 7.6 Thermal power

*The following table shows the values of thermal power  $P_{10}$  (kW) for each gearbox size.*

#### 7.6 Thermische Leistung

Die folgende Tabelle zeigt die Werte  $P_{10}$  der thermischen Leistung (kW) je nach Getriebegröße.

Tab. 2

$n_1$ [min <sup>-1</sup> ]	$P_{10}$ [kW] - Potenza Termica / Thermal power / Thermische Leistung				
	L19	L24	L28	L38	L48
1400	4.5	6.7	10.3	15.3	22.4

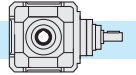

7.7 Dati tecnici

7.7 Technical data

7.7 Technische Daten7

L	n <sub>1</sub> = 1400			LC - LF			LA	
	in	ir	n <sub>2</sub> rpm	T <sub>2</sub> Nm	P1 kW	FS'	T <sub>2M</sub> Nm	P kW
19	1	1	1400	12	1.8	3	35	5.5
	2	2	700	24	1.8	1.7	40	3
	3	3	467	36	1.8	1.2	43	2.2
24	1	1	1400	26	4	2.7	73	11
	2	2	700	53	4	1.4	72	5.5
	3	3	467	78	4	1	78	4
28	1	1	1400	61	9.2	2.4	146	22
	2	2	700	122	9.2	1.2	145	11
	3	3	467	182	9.2	1	182	9.2

L	n <sub>1</sub> = 1400			LC - LF			LA	
	in	ir	n <sub>2</sub> rpm	T <sub>2</sub> Nm	P1 kW	FS'	T <sub>2M</sub> Nm	P kW
38	1	1	1400	146	22	2	298	45
	2	2	700	291	22	1	291	22
	3	3	467	297	15	1	297	15
48	1	1	1400	199	30	3	596	90
	2	2	700	397	30	1.5	583	45
	3	3	467	597	30	1	597	30

Verifica termica necessaria / Thermal rating needed / Thermische - Prüfung erforderlich

L	i	IEC									
		63	71	80	90	100	112	132	160	180	200
19	1-2-3	LC - LF									
24	1-2-3	LC - LF									
28	1-2-3	LC - LF									
38	1-2-3	LC - LF									
48	1-2-3	LC - LF									

7.8 Senso di rotazione alberi

7.8 Shaft Rotation Direction

7.8 Wellendrehrrichtungen

s.e. = Entrata supplementare / Additional input / Zusatzantrieb

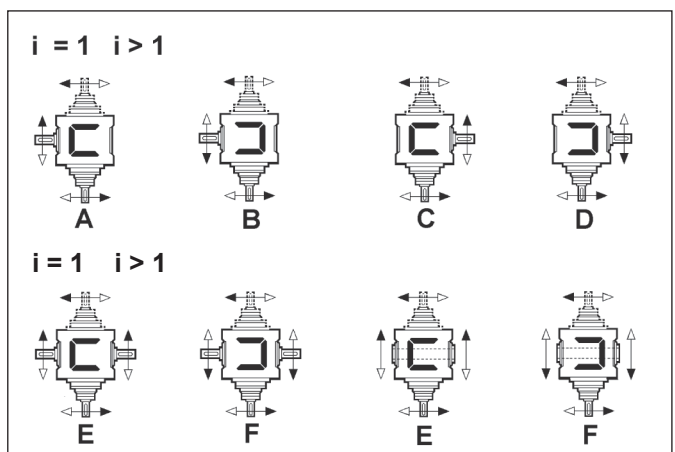
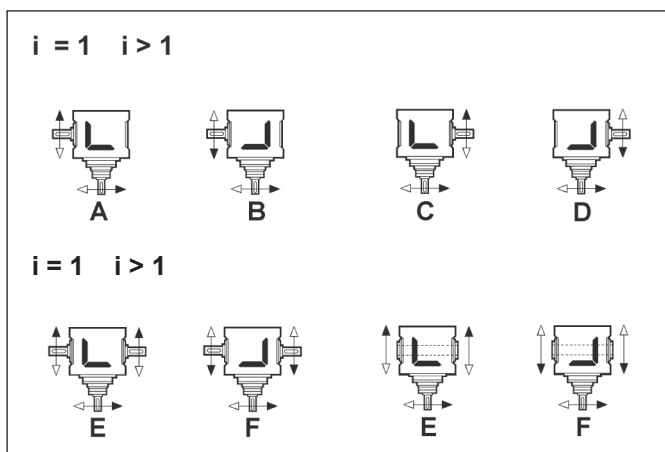

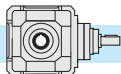











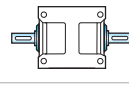





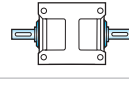

**7.9 Momenti d'inerzia [Kg·cm<sup>2</sup>]**  
(riferiti all'albero veloce in entrata)

**7.9 Moments of inertia [Kg·cm<sup>2</sup>]**  
(referred to input shaft)





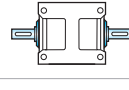

**7.9 Trägheitsmoment [Kg·cm<sup>2</sup>]**  
(bez. Antriebswelle)

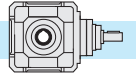



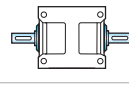

		$i_n$	LA 	 LC				 LF			
				IEC B5				IEC B5			
				63	71	80	90	63	71	80	90
<b>19</b>	<b>S</b> 	1	4.10	4.15	4.28	4.65	4.68	4.80	4.86	4.99	5.98
		2	1.07	1.12	1.26	1.63	1.66	1.33	1.34	2.00	2.97
		3	0.58	0.65	0.78	1.15	1.18	0.83	0.85	1.51	2.48
	<b>B</b> 	1	4.15	4.19	4.33	4.70	4.73	4.85	4.91	5.04	6.02
		2	1.09	1.14	1.28	1.65	1.68	1.35	1.36	2.02	2.99
		3	0.59	0.66	0.79	1.16	1.19	0.84	0.86	1.52	2.49
	<b>C</b> 	1	3.89	3.93	4.07	4.44	4.47	4.59	4.65	4.78	5.77
		2	1.03	1.08	1.22	1.58	1.62	1.28	1.30	1.95	2.93
		3	0.56	0.63	0.76	1.13	1.16	0.82	0.83	1.49	2.46

		$i_n$	LA 	 LC				 LF			
				IEC B5				IEC B5			
				71	80	90	100-112	71	80	90	100-112
<b>24</b>	<b>S</b> 	1	10.95	11.27	11.43	11.80	12.62	12.69	13.02	12.95	14.61
		2	2.75	3.16	3.32	3.69	4.51	3.59	3.72	4.81	6.88
		3	1.77	2.16	2.33	2.69	3.51	2.60	2.74	3.83	5.90
	<b>B</b> 	1	11.07	11.38	11.54	11.91	12.73	12.80	13.13	13.06	14.72
		2	2.79	3.20	3.37	3.73	4.55	3.63	3.77	4.86	6.92
		3	1.79	2.18	2.35	2.71	3.53	2.62	2.76	3.85	5.91
	<b>C</b> 	1	10.31	10.62	10.78	11.14	11.97	12.04	12.37	12.30	13.96
		2	2.61	3.01	3.18	3.54	4.36	3.44	3.58	4.67	6.73
		3	1.7	2.10	2.26	2.63	3.45	2.54	2.67	3.76	5.83

		$i_n$	LA 	 LC				 LF			
				IEC B5				IEC B5			
				80	90	100-112	132	80	90	100-112	132
<b>28</b>	<b>S</b> 	1	27.38	28.26	28.12	29.01	32.12	31.51	31.46	31.64	41.92
		2	8.78	9.62	9.49	10.37	13.48	11.01	10.94	13.15	26.41
		3	4.48	5.57	5.43	6.32	9.43	6.71	6.64	8.85	22.11
	<b>B</b> 	1	27.85	28.73	28.59	29.47	32.59	31.98	31.93	32.11	42.39
		2	8.87	9.71	9.58	10.46	13.57	11.10	11.03	13.24	26.50
		3	4.52	5.61	5.47	6.35	9.46	6.75	6.68	8.90	22.15
	<b>C</b> 	1	26.07	26.95	26.82	27.70	30.81	30.20	30.15	30.33	40.61
		2	8.42	9.27	9.13	10.01	13.12	10.65	10.58	12.79	26.05
		3	4.32	5.41	5.27	6.16	9.27	6.55	6.47	8.69	21.95

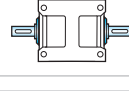

		$i_n$	LA 	 LC					 LF				
				90	100-112	132	160	180	90	100-112	132	160	180
				<b>38</b>	<b>S</b> 	1	72.43	73.09	73.20	76.34	80.53	83.31	88.11
2	21.35	22.19	22.29			25.44	29.63	32.41	25.72	25.90	40.02	42.20	88.73
3	12.48	14.08	14.18			17.33	21.52	24.3	16.85	17.03	31.16	33.34	79.87
<b>B</b> 	1	74.74	75.40		75.50	78.65	82.84	85.62	90.42	91.47	92.83	95.01	141.38
	2	21.89	22.74		22.84	25.99	30.18	32.95	26.27	26.45	40.57	42.75	89.28
	3	12.73	14.32		14.42	17.57	21.76	24.54	17.10	17.28	31.40	33.58	80.11
<b>C</b> 	1	67.80	68.47		68.57	71.71	75.91	78.68	83.49	84.53	85.59	88.07	134.45
	2	20.16	21		21.1	24.25	28.44	31.22	24.53	24.71	38.83	41.01	87.54
	3	11.95	13.55		13.65	16.8	20.99	23.77	16.32	16.50	30.63	32.81	79.34

		$i_n$	LA 	 LC					 LF				
				IEC B5					IEC B5				
				100-112	132	160	180	200	100-112	132	160	180	200
<b>48</b>	<b>S</b> 	1	156.56	156.20	161.84	160.75	163.51	173.60	207.50	212.72	220.70	218.70	215.23
		2	62.54	64.58	70.22	69.13	71.89	81.98	81.21	82.57	84.75	135.14	131.67
		3	44.14	47.03	52.68	51.58	54.35	64.44	62.81	64.17	66.35	116.74	113.26
	<b>B</b> 	1	162.50	162.13	167.78	166.68	169.45	179.53	213.44	218.66	226.63	224.64	221.16
		2	63.94	65.97	71.62	70.52	73.29	83.38	82.61	83.97	86.15	136.54	133.06
		3	44.76	47.66	53.30	52.20	54.97	65.06	63.43	64.79	66.97	117.34	113.88
	<b>C</b> 	1	141.58	141.21	146.85	145.78	148.52	158.61	192.52	197.73	205.71	203.71	200.24
		2	58.70	60.74	66.38	65.29	68.05	78.14	77.37	78.74	80.92	131.30	127.83
		3	42.43	45.33	50.97	49.88	52.64	62.73	61.11	62.47	64.65	115.03	111.56



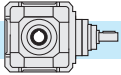

7.10 Dimensioni

7.10 Dimensions

7.10 Abmessungen

		LA...- LC...- LF...					
		19	24	28	38	48	
<b>A</b>	i = 1	112	142	180	224	280	
<b>a</b>		80	100	130	160	190	
<b>B</b>		128	146	175	204	230	
<b>b</b>		110	125	145	175	200	
<b>C2</b>		130	150	180	210	240	
<b>D2 h6</b>		19	24	28	38	48	
<b>d2</b>		M8	M8	M8	M10	M12	
<b>M2</b>		21.5	27	31	41	51.5	
<b>N2</b>		6	8	8	10	14	
<b>L2</b>		i > 1	40	50	60	80	110
<b>F</b>			7	9	11	13	15
<b>H</b>			56	71	90	112	140
<b>Z</b>			7	9	10	13	15
<b>D4 H7</b>			20	25	30	40	50
<b>M4</b>			22.8	28.3	33.3	43.3	53.8
<b>N4</b>			6	8	8	12	14
<b>L1</b>			30	40	50	60	80
<b>X</b>	90		110	130	150	175	

		LA				
		19	24	28	38	48
<b>h</b>	i = 1	101	120	147	170	207.5
<b>D1 h6</b>		19	24	28	38	48
<b>d1</b>		M8	M8	M8	M10	M12
<b>M1</b>		21.5	27	31	41	51.5
<b>N1</b>	6	8	8	10	14	
<b>h</b>	i > 1	101	120	147	170	227.5
<b>D1 h6</b>		14	19	24	28	38
<b>d1</b>		M6	M8	M8	M8	M10
<b>M1</b>		16	21.5	27	31	41
<b>N1</b>		5	6	8	8	10
		LA				
<b>kg</b>		8.5	14	23	38	62
		LC...- LF...				
<b>kg</b>		11.5	19	33	55	82



		LC...								
		19				24				
<b>IEC</b>		63 B5	71 B5	80/90 B5	80 B14	71 B5	80 B5	90 B5	90* B14	100/112 B5
<b>Q</b>		—	—	—	—	—	—	—	120	—
<b>Y</b>		140	160	200	120	160	200	200	146	250
<b>P</b>	i = 1	104	111	131	131	128	148	148	148	158
<b>P</b>	i > 1	104	111	131	131	128	148	148	148	158

\* Flange quadrate / Square flanges / Viereckige Flansche



		LC...										
		28			38				48			
<b>IEC</b>		80/90 B5	100/112 B5	132 B5	90 B5	100/112 B5	132 B5	160/180 B5	100/112 B5	132 B5	160/180 B5	200 B5
<b>Y</b>		200	250	300	200	250	300	350	250	300	350	400
<b>P</b>	i = 1	171	181	203	184	194	216	246	220	240	270	270
<b>P</b>	i > 1	171	181	203	184	194	216	246	240	260	290	290

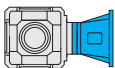

		LF...																			
		19				24				28				38				48			
<b>IEC</b>		63 B5	71 B5	80/90 B5	71 B5	80/90 B5	100/112 B5	80/90 B5	100/112 B5	132 B5	90 B5	100/112 B5	132 B5	160/180 B5	100/112 B5	132 B5	160/180 B5	200 B5			
<b>Y</b>		140	160	200	160	200	250	200	250	300	200	250	300	350	250	300	350	400			
<b>P</b>	i = 1	158	165	186	194	215	225	252	262	283	285	295	316	346	354	373	405	405			
<b>P</b>	i > 1	158	165	186	194	215	225	252	262	283	285	295	316	346	374	393	425	425			

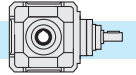

Tipo entrata / Input type / Antriebsart

Tipo uscita / Output type / Ausgang Typ

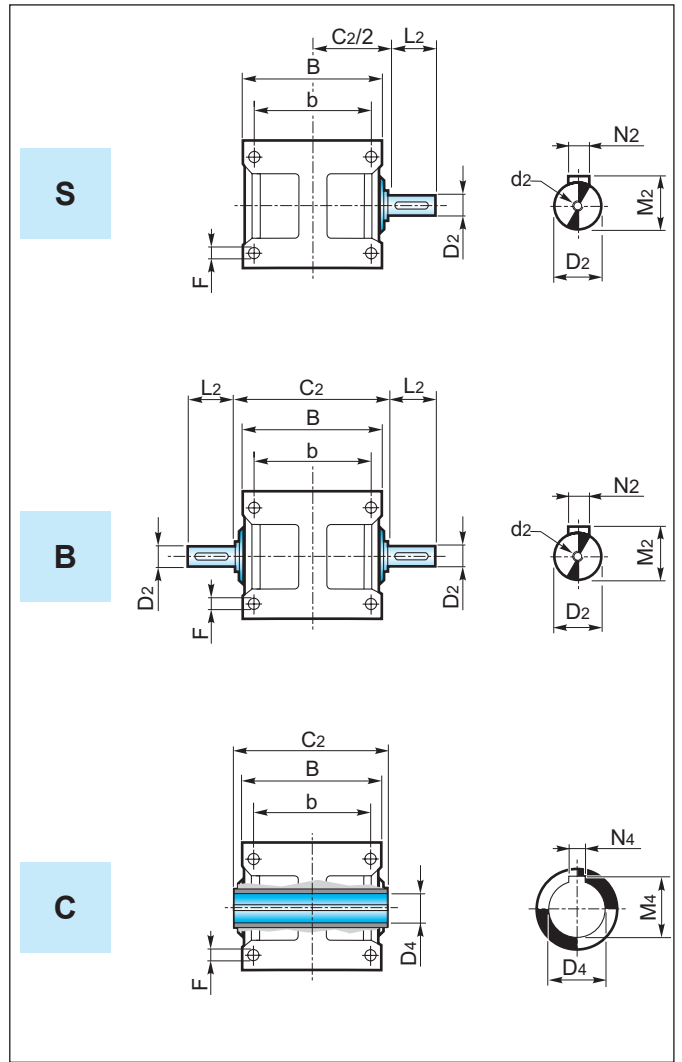
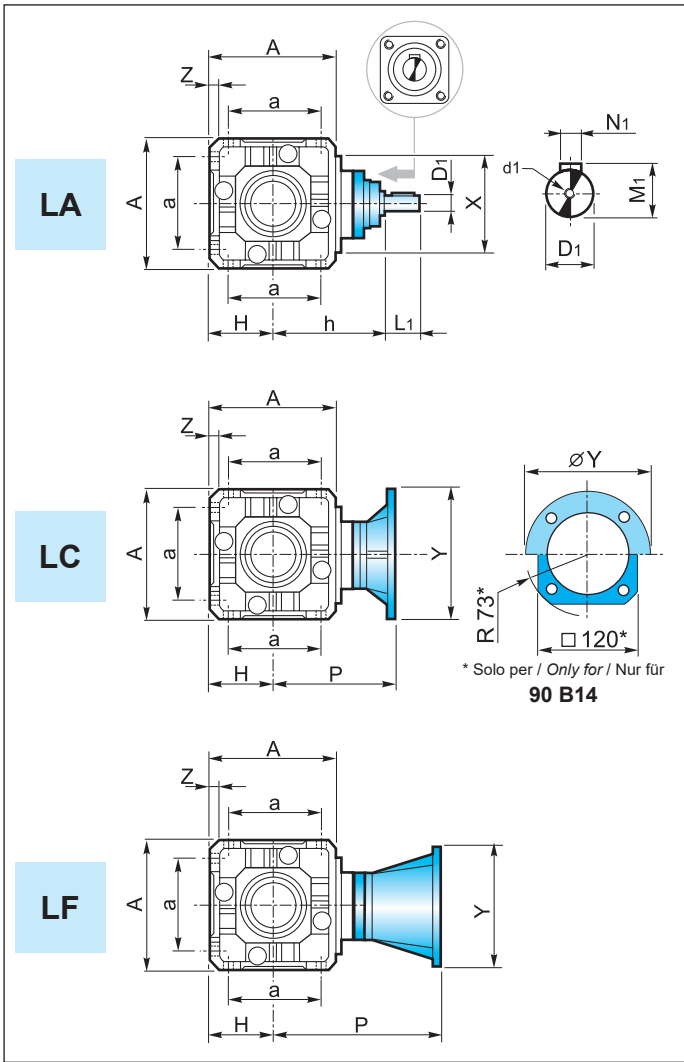

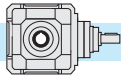

### 7.11 Accessori

### 7.11 Accessories

### 7.11 Zubehör

#### Flangia uscita

#### Output flange

#### Abtriebsflansch

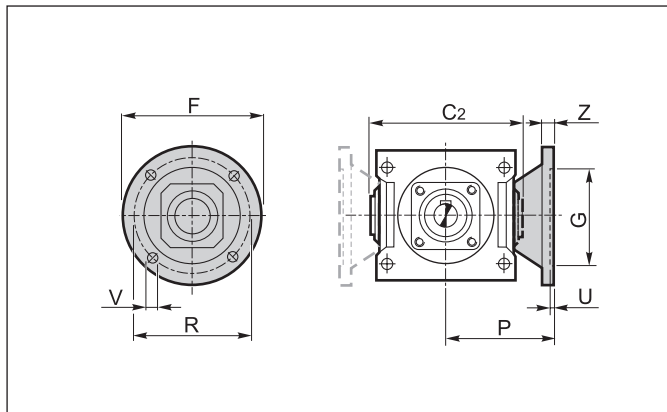

	L				
	19	24	28	38	48
<b>C2</b>	130	150	180	210	240
<b>F</b>	140	160	200	250	250
<b>G<sub>F7</sub></b>	95	110	130	180	180
<b>P</b>	86	100	120	145	175
<b>R</b>	115	130	165	215	215
<b>U</b>	3.5	4	4.5	5	5
<b>V</b>	9	11	13	15	15
<b>Z</b>	10	12.5	16	20	20

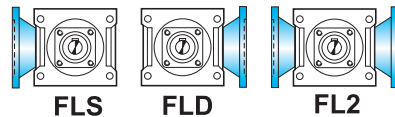

### 7.12 Lubrificazione

### 7.12 Lubrication

### 7.12 Schmierung

I rinvii angolari sono forniti predisposti per lubrificazione a olio e muniti dei tappi di carico, livello e scarico olio.

Si raccomanda di precisare sempre la posizione di montaggio desiderata in fase di ordine.

Il rinvio grandezza 19 viene fornito lubrificato a vita e non è previsto il tappo di sfiato.

Right angle gearboxes require oil lubrication and are equipped with filler, level and drain plugs.

The mounting position should always be specified when ordering the gearbox.

The right angle gearbox size 19 is lubricated for life and without breather plug.

Die Winkelgetriebe sind für die Ölschmierung mit Einfüll-, Ölstand- und Ablassstopfen versehen.

Bei der Bestellung ist immer die gewünschte Montageposition anzugeben.

Das Winkelgetriebe Größe 19 ist Lebensdauer geschmiert und ohne Entlüftungsschraube.

#### Posizione di montaggio e quantità di lubrificante (litri)

#### Mounting positions and lubricant quantity (litres)

#### Montageposition und Ölmenge (Liter)

I quantitativi di olio riportati nelle varie tabelle sono indicativi e riferiti alle posizioni di lavoro indicate e considerando le condizioni di funzionamento a temperatura ambiente e velocità in ingresso di 1400 min<sup>-1</sup>. Per condizioni di lavoro diverse da quelle sopra riportate contattare il servizio tecnico.

The oil quantities stated in the tables are approximate values and refer to the indicated working positions, considering operating conditions at ambient temperature and an input speed of 1400 min<sup>-1</sup>. Should the operating conditions be different, please contact the technical service.

Die in der Tabellen angegebenen Daten sind Richtwerte. Die Ölmenge beziehen sich auf die angegebene Betriebsposition. Dabei werden Betrieb bei Umgebungstemperatur und Antriebsdrehzahl von 1400 min<sup>-1</sup> berücksichtigt. Falls die Betriebsbedingungen anders sind, dann ist das technische Büro zu befragen.

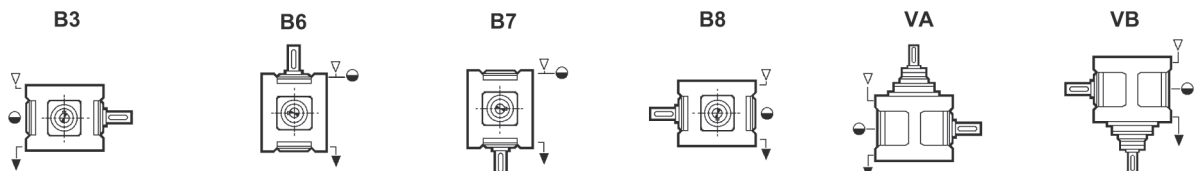

L	B3	B6	B7	B8	VA	VB
19	0.2	0.2	0.2	0.2	0.2	0.2
24	0.4	0.8	0.8	0.4	0.6	0.5
28	0.9	1.6	1.6	0.8	0.9	0.8
38	1.6	3.0	3.0	2.0	2.7	2.7
48	4.0	5.6	5.6	4.0	5.6	5.6

#### Posizione morsettiera

#### Terminal board position

#### Lage des Klemmenkastens

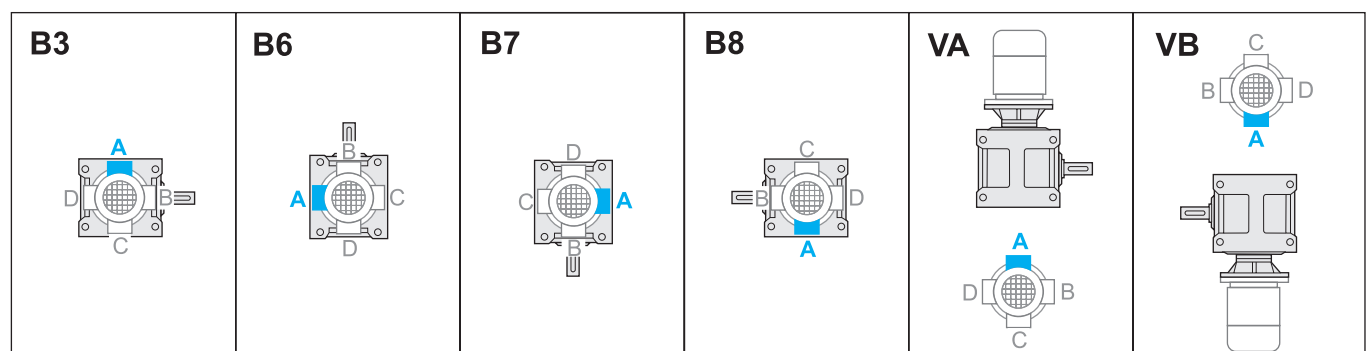

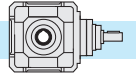

### 7.13 Carichi radiali e assiali (N)

Le trasmissioni effettuate tramite pignoni per catena, ruote dentate o pulegge generano delle forze radiali ( $F_R$ ) sugli alberi dei riduttori. L'entità di tali forze può essere calcolata con la formula:

### 7.13 Radial and axial loads (N)

Transmissions implemented by means of chain pinions, wheels or pulleys generate radial forces ( $F_R$ ) on the gear unit shafts. The entity of these forces may be calculated using the following formula:

### 7.13 Radial- und Axialbelastungen (N)

Antriebe mit Kettenritzel, Zählrädern oder Riemenscheiben erzeugen radiale Kräfte ( $F_R$ ) an den Wellen der Untersetzungsgetriebe. Die Größe dieser Kraft kann nach folgender Formel berechnet werden:

$$F_R = \frac{K_R \cdot T}{d} \text{ [N]}$$

dove:

T = Momento torcente [Nm]

d = Diametro pignone o puleggia [mm]

$K_R$  = 2000 per pignone per catena

= 2500 per ruote dentate

= 3000 per puleggia con cinghie a V

where:

T = torque [Nm]

d = pinion or pulley diameter [mm]

$K_R$  = 2000 for chain pinion

= 2500 for wheel

= 3000 for V-belt pulley

dabei ist:

T = Drehmoment [Nm]

d = Kettenritzel- bzw. Riemenscheiben durchmesser [mm]

$K_R$  = 2000 bei Kettenritzel

= 2500 bei Zahnrad

= 3000 bei Riemenscheibe mit Keilriemen

I valori dei carichi radiali e assiali generati dall'applicazione debbono essere sempre minori o uguali a quelli ammissibili indicati nelle tabelle.

The values of the radial and axial loads generated by the application must always be lower than or equal to the admissible values reported in the tables.

Die Werte der Radial- und Axialbelastungen, die durch die Anwendung hervorgerufen werden, dürfen nicht über den in den Tabellen angegebenen zulässigen Werten liegen.

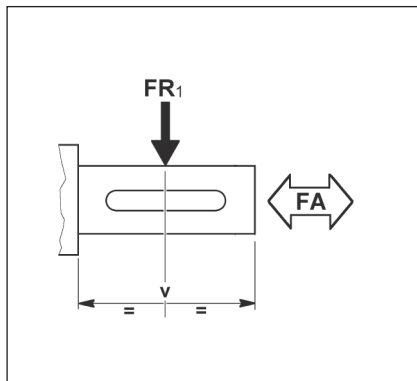

$i_n$	L									
	19		24		28		38		48	
<b>ALBERO ENTRATA / INPUT SHAFT / ANTRIEBSWELLE (<math>n_1 = 1400 \text{ min}^{-1}</math>)</b>										
	$Fr_1$	$Fa_1$	$Fr_1$	$Fa_1$	$Fr_1$	$Fa_1$	$Fr_1$	$Fa_1$	$Fr_1$	$Fa_1$
Tutti All Alle	400	80	630	125	1000	200	1600	320	2500	500
<b>ALBERO USCITA / OUTPUT SHAFT / ABTRIEBSWELLE (<math>n_1 = 1400 \text{ min}^{-1}</math>)</b>										
	$Fr_2$	$Fa_2$	$Fr_2$	$Fa_2$	$Fr_2$	$Fa_2$	$Fr_2$	$Fa_2$	$Fr_2$	$Fa_2$
1	800	160	1250	250	2000	400	3150	630	5000	1000
2 - 3	1000	160	1600	320	2500	500	4000	800	5000	1000

I carichi radiali indicati nelle tabelle si intendono applicati a metà della sporgenza dell'albero e sono riferiti ai riduttori operanti con fattore di servizio 1.

The radial loads reported in the table are considered to be applied at the half-way point of the shaft projection and refer to gear units operating with service factor 1.

Die Radialbelastungen, die in den Tabellen angegeben werden, gelten für Ansatzpunkte in der Mitte des herausragenden Wellenteils und für Getriebe mit Betriebsfaktor 1.

Nel caso di alberi bisporgenti il valore del carico applicabile a ciascuna estremità è uguale ai 2/3 del valore di tabella, purché i carichi applicati siano uguali di intensità e direzione ed agiscano nello stesso senso. Diversamente contattare il servizio tecnico.

With regard to double-projecting shafts, the load applicable at each end is 2/3 of the value given in the table, on condition that the applied loads feature same intensity and direction and that they act in the same direction. Otherwise please contact the technical department.

Bei doppelseitigen Wellen ist die Belastung, die an jedem Ende anwendbar ist, 2/3 des in der Tabelle angegebenen Wertes unter der Bedingung, dass sie in derselben Stärke und Richtung wirken. Andernfalls muß mit dem technischen Büro Rücksprache gehalten werden.

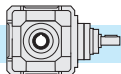

**LA - LC - LF (in = 1)**

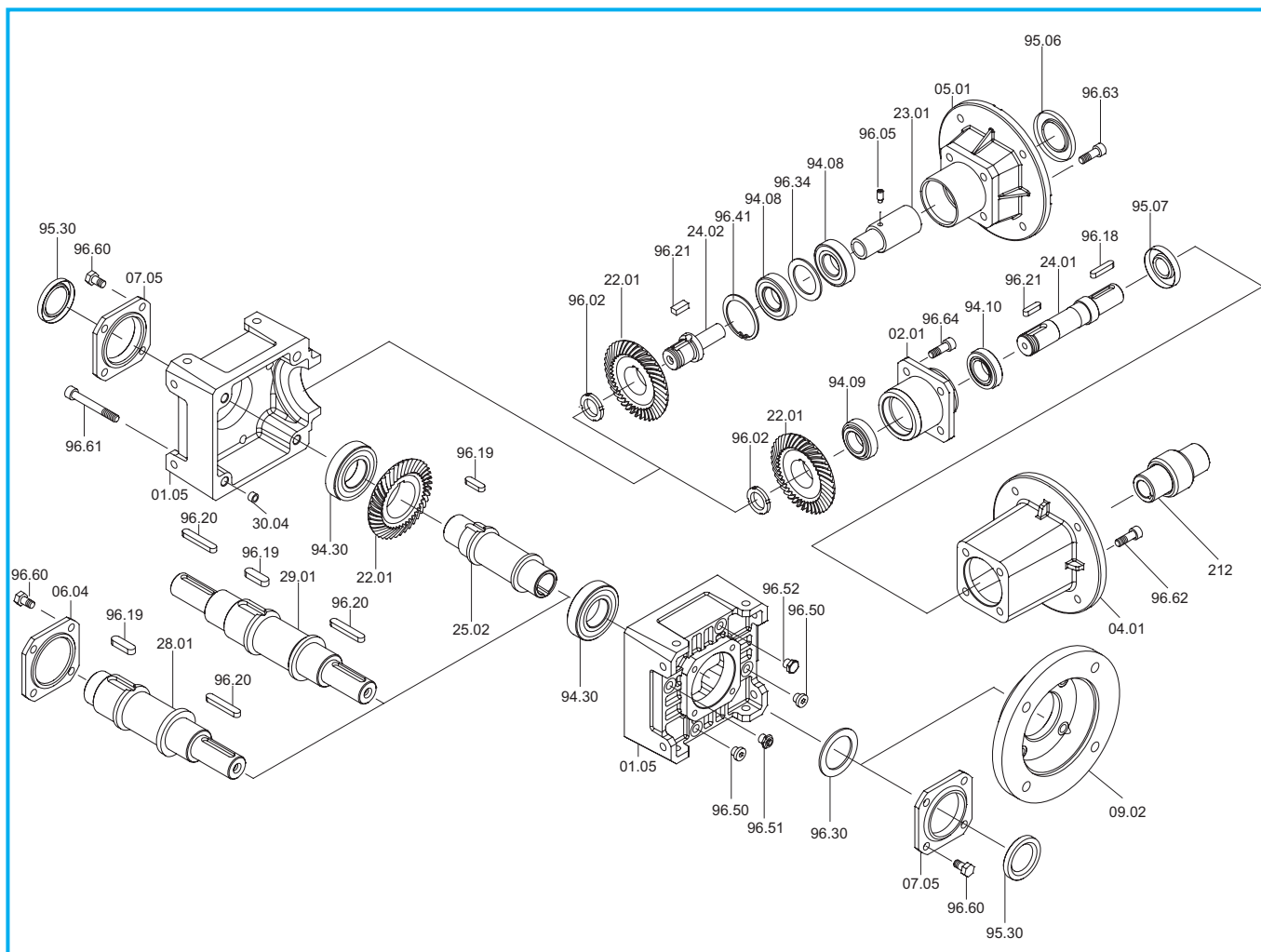

LA - LC - LF in = 1:1	Cuscinetti / Bearings / Lager			Anelli di tenuta / Oilseals / Öldichtungen			
	LA - LC - LF	LA - LF	LC	LA - LC - LF	LC	LA - LF	
	94.30	94.10 - 94.09	94.08	95.30	IEC	95.06	95.07
<b>19</b>	<b>6206</b> 30/62/16	<b>30203</b> 17/40/13.25	<b>7203</b> 17/40/12	30/47/7	63	<b>25/52/7</b>	<b>20/40/7</b>
					71	<b>30/52/7</b>	
					80	<b>35/52/7</b>	
					90	<b>37/52/8</b>	
<b>24</b>	<b>6207</b> 35/72/17	<b>32005</b> 25/47/15	<b>7205</b> 25/52/15	35/52/7	71 - 80	<b>35/62/7</b>	<b>30/47/7</b>
					90	<b>40/62/7</b>	
					100 - 112	<b>45/62/8</b>	
<b>28</b>	<b>6208</b> 40/80/18	<b>32006</b> 30/55/17	<b>7206</b> 30/62/16	40/62/8	80 - 90	<b>40/72/7</b>	<b>35/58/10</b>
					100 - 112	<b>45/72/8</b>	
					132	<b>55/72/8</b>	
<b>38</b>	<b>30211</b> 55/100/22.75	<b>32007</b> 35/62/18	<b>7207</b> 35/72/17	55/72/10	90	<b>45/80/10</b>	<b>40/62/7</b>
					100 - 112	<b>45/80/10</b>	
					132	<b>55/80/10</b>	
					160	<b>60/80/8</b>	
<b>48</b>	<b>30213</b> 65/120/24.75	<b>33109</b> 45/80/26	<b>7209</b> 45/85/19	65/90/10	180	<b>65/80/8</b>	<b>55/80/8</b>
					100 - 112	<b>55/100/13</b>	
					132 - 160	<b>60/100/10</b>	
					200	<b>75/100/10</b>	

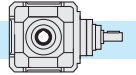

## LA - LC - LF (in > 1)

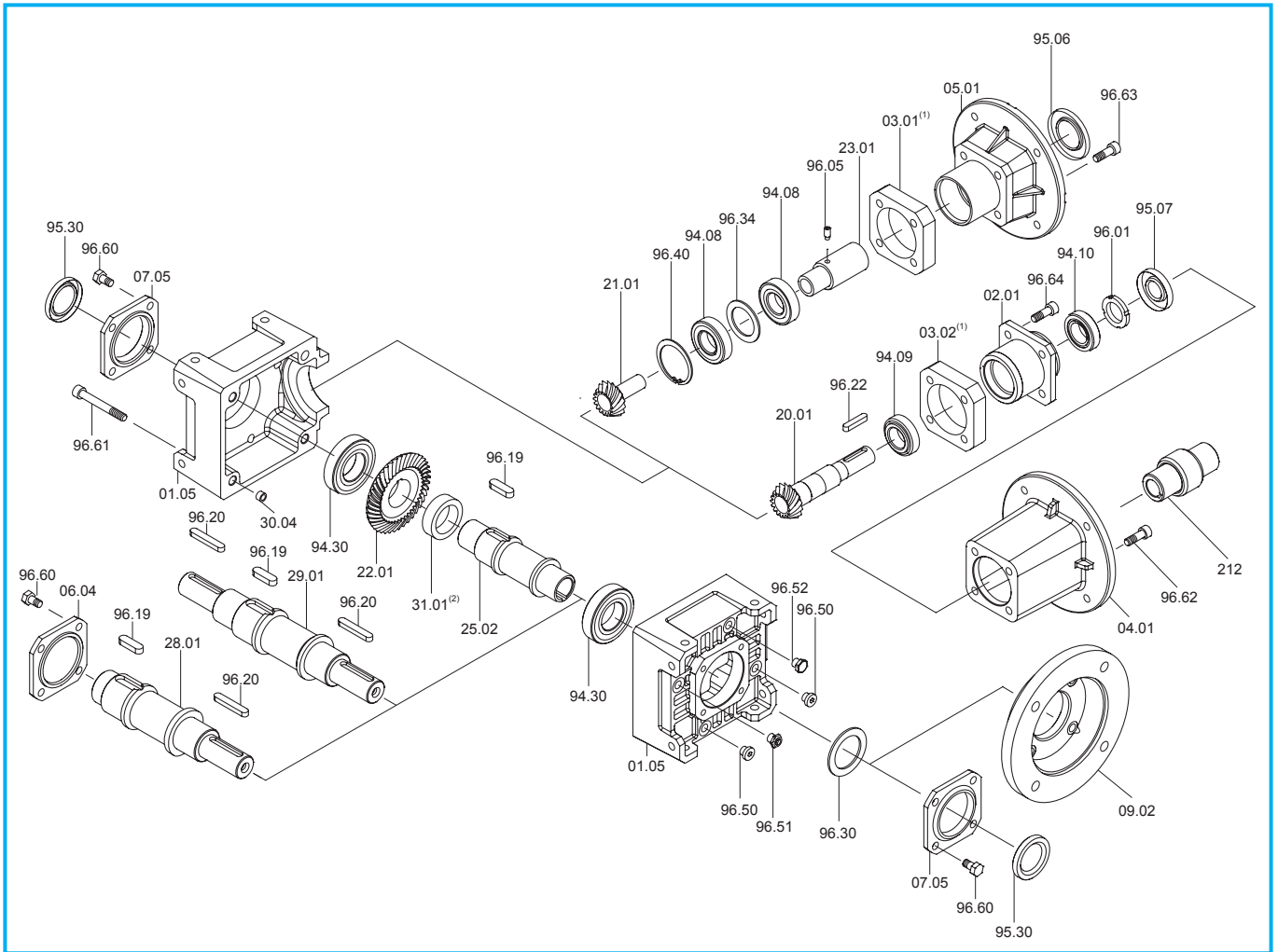

(1): Solo per L48 i>1 / Only for R48 i>1 / Nur für R48 i>1

(2): Solo per L19 i=2 / Only for L19 i=2 / Nur für i=2

LA - LC - LF in > 1	Cuscinetti / Bearings / Lager			Anelli di tenuta / Oilseals / Öldichtungen			
	LA - LC - LF	LA - LF	LC	LA - LC - LF	LC	LA - LF	
	94.30	94.10 - 94.09	94.08	95.30	IEC	95.06	95.07
<b>19</b>	<b>6206</b> 30/62/16	<b>30203</b> 17/40/13.25	<b>7203</b> 17/40/12	30/47/7	63	<b>25/52/7</b>	<b>15/40/10</b>
					71	<b>30/52/7</b>	
					80	<b>35/52/7</b>	
					90	<b>37/52/8</b>	
<b>24</b>	<b>6207</b> 35/72/17	<b>32005</b> 25/47/15	<b>7205</b> 25/52/15	35/52/7	71 - 80	<b>35/62/7</b>	<b>20/47/7</b>
					90	<b>40/62/7</b>	
					100 - 112	<b>45/62/8</b>	
<b>28</b>	<b>6208</b> 40/80/18	<b>32006</b> 30/55/17	<b>7206</b> 30/62/16	40/62/8	80 - 90	<b>40/72/7</b>	<b>25/58/10</b>
					100 - 112	<b>45/72/8</b>	
					132	<b>55/72/8</b>	
<b>38</b>	<b>30211</b> 55/100/22.75	<b>32007</b> 35/62/18	<b>7207</b> 35/72/17	55/72/10	90	<b>45/80/10</b>	<b>30/62/7</b>
					100 - 112	<b>45/80/10</b>	
					132	<b>55/80/10</b>	
					160	<b>60/80/8</b>	
<b>48</b>	<b>30213</b> 65/120/24.75	<b>33109</b> 45/80/26	<b>7209</b> 45/85/19	65/90/10	180	<b>65/80/8</b>	<b>40/80/10</b>
					100 - 112	<b>55/100/13</b>	
					132 - 160	<b>60/100/10</b>	
					200	<b>75/100/10</b>	

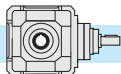

**LA - LC - LF (in = 1) s.e.**

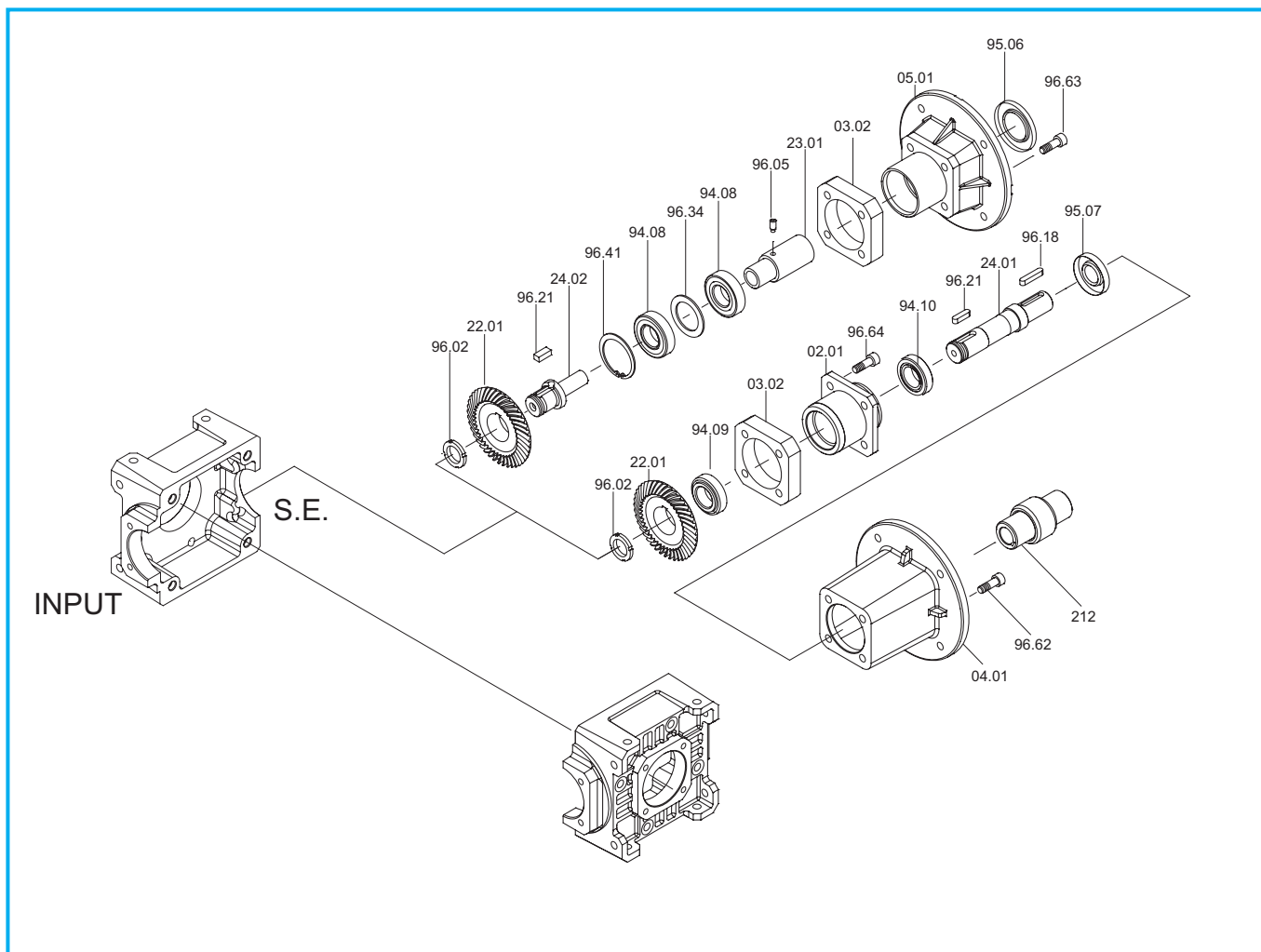

LA - LC - LF in = 1:1 S.E	Cuscinetti/ Bearings / Lager		Anelli di tenuta / Oilseals / Öldichtungen		
	LA - LF	LC	LC		LA - LF
	94.10 - 94.09	94.08	IEC	95.06	95.07
<b>19</b>	<b>30203</b> 17/40/13.25	<b>7203</b> 17/40/12	63	<b>25/52/7</b>	<b>20/40/7</b>
			71	<b>30/52/7</b>	
			80	<b>35/52/7</b>	
			90	<b>37/52/8</b>	
<b>24</b>	<b>32005</b> 25/47/15	<b>7205</b> 25/52/15	71 - 80	<b>35/62/7</b>	<b>30/47/7</b>
			90	<b>40/62/7</b>	
			100 - 112	<b>45/62/8</b>	
<b>28</b>	<b>32006</b> 30/55/17	<b>7206</b> 30/62/16	80 - 90	<b>40/72/7</b>	<b>35/58/10</b>
			100 - 112	<b>45/72/8</b>	
			132	<b>55/72/8</b>	
<b>38</b>	<b>32007</b> 35/62/18	<b>7207</b> 35/72/17	90	<b>45/80/10</b>	<b>40/62/7</b>
			100 - 112	<b>45/80/10</b>	
			132	<b>55/80/10</b>	
			160	<b>60/80/8</b>	
<b>48</b>	<b>33109</b> 45/80/26	<b>7209</b> 45/85/19	180	<b>65/80/8</b>	<b>55/80/8</b>
			100 - 112	<b>55/100/13</b>	
			132 - 160	<b>60/100/10</b>	
			200	<b>75/100/10</b>	

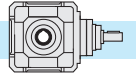

**LA - LC - LF (in > 1) s.e.**

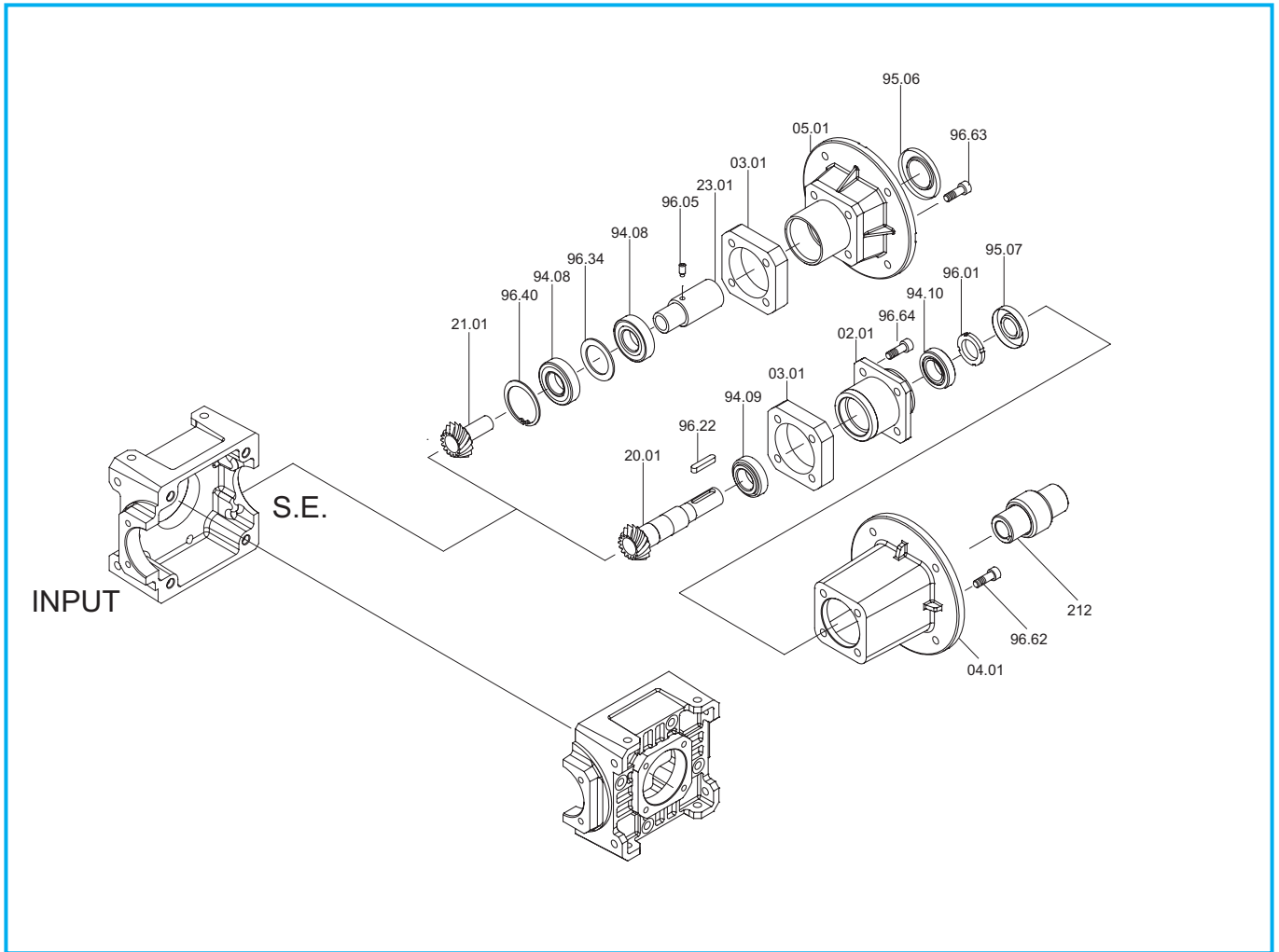

LA - LC - LF in > 1 S.E	Cuscinetti/ Bearings / Lager		Anelli di tenuta / Oilseals / Öldichtungen		
	LA - LF	LC	LC		LA - LF
	94.10 - 94.09	94.08	IEC	95.06	95.07
19	32023 17/40/13.25	7203 17/40/12	63	25/52/7	15/40/10
			71	30/52/7	
			80	35/52/7	
			90	37/52/8	
24	32005 25/47/15	7205 25/52/15	71 - 80	35/62/7	20/47/7
			90	40/62/7	
			100 - 112	45/62/8	
28	32006 30/55/17	7206 30/62/16	80 - 90	40/72/7	25/58/10
			100 - 112	45/72/8	
			132	55/72/8	
38	32007 35/62/18	7207 35/72/17	90	45/80/10	30/62/7
			100 - 112	45/80/10	
			132	55/80/10	
			160	60/80/8	
48	33109 45/80/26	7209 45/85/19	180	65/80/8	40/80/10
			100 - 112	55/100/13	
			132 - 160	60/100/10	
			180	65/100/10	
			200	75/100/10	



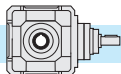

### 7.14 Lista parti di ricambio

### 7.14 Spare parts list

### 7.14 Ersatzteilliste

In fase di ordine delle parti di ricambio, specificare sempre n° particolare (vedi disegno esploso), data (1), n° codice (2) e n° variante (3). (Vedi targhetta).

*When ordering a spare part, the spare part number (see exploded technical drawing), the date (1), the code number (2) and the variant number (3) should always be reported. (See plate)*

Bei der Bestellung von Ersatzteilen sind Ersatzteilnummer (s. Explosionszeichnung), Datum (1), Artikelnummer (2) und Variantennummer (3) anzugeben. (s. Schild)

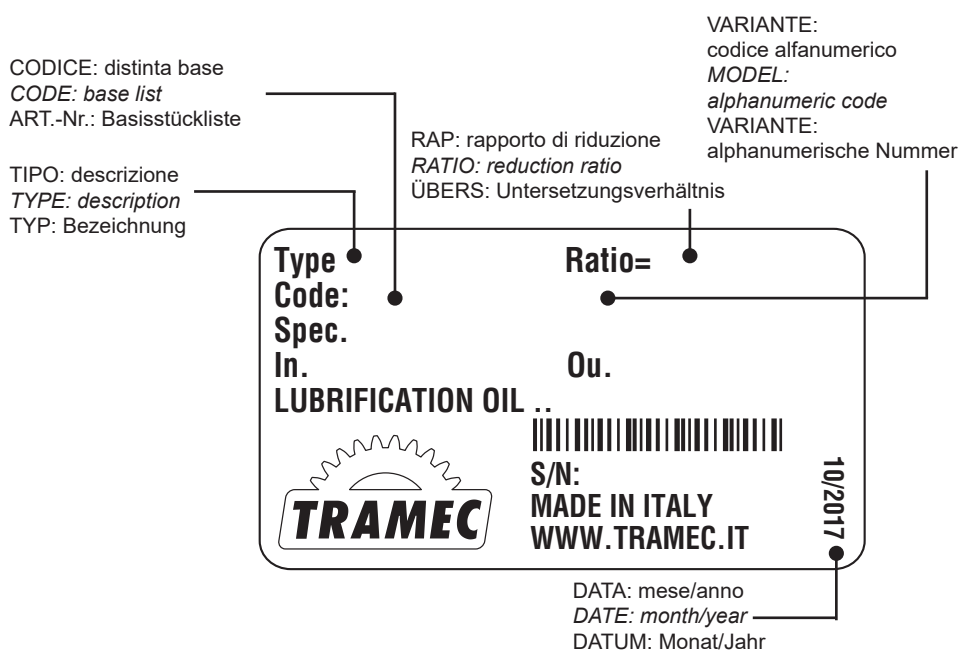

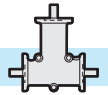

## 8.0 RINVII ANGOLARI RL *RIGHT ANGLE GEARBOX RL* WINKELGETRIEBE

8.1	Caratteristiche	<i>Characteristics</i>	Merkmale	128
8.2	Designazione	<i>Designation</i>	Bezeichnung	129
8.3	Fattore di servizio FS	<i>Service factor FS</i>	Betriebsfactor FS	130
8.4	Dati tecnici	<i>Technical data</i>	Technische Daten	130
8.5	Carichi radiali e assiali (N)	<i>Radial and axial loads (N)</i>	Radial und axial Belastungen (N)	130
8.6	Dimensioni	<i>Dimensions</i>	Abmessungen	131

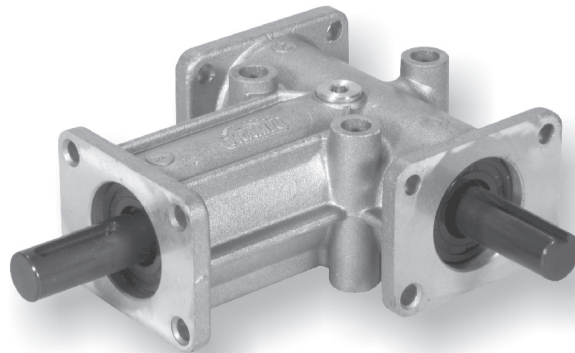



I rinvii angolari serie **RL** sono stati progettati per applicazioni industriali ove occorre trasmettere un moto rotatorio di potenza tra alberi disposti perpendicolarmente tra loro.

Possono essere a 2 o 3 uscite con rapporto di trasmissione: 1:1 o 2:1.

*The right angle gearboxes RL Series have been designed for industrial applications when rotary power must be transferred to the shafts perpendicularly arranged. They could have 2 or 3 output shafts and have 1:1 or 2:1 ratio.*

Die Winkelgetriebe der Serie **RL** sind für den industriellen Einsatz ausgelegt und wenn die Drehbewegung um 90° umgelenkt werden muss. Die Getriebe sind mit 2 oder 3 Wellenenden ausgeführt und können mit Untersetzungsverhältnissen von 1:1 oder 1:2 geliefert werden.

## 8.1 Caratteristiche

### Carter

Monoblocco rigido in lega d'alluminio con 5 piani di attacco e 3 possibilità di centraggio.

### Ingranaggi

Conici a dentatura spiroidale GLEASON. Sono costruiti in acciaio al Nickel-Cromo e sottoposti ad un trattamento superficiale di cementazione e tempra e successivo rodaggio. Il gioco angolare fra gli ingranaggi è regolato per garantire un ingranamento ed una silenziosità ottimali; a richiesta possono essere forniti con gioco angolare ridotto fino a 5'.

### Alberi

Sono costruiti in acciaio con una resistenza di 80 Kg/mm<sup>2</sup> e protetti superficialmente contro la corrosione.

L'attacco esterno è previsto con un trasciamamento a linguetta a norma UNI (ad eccezione della grandezza 1). Le posizioni angolari delle linguette sugli alberi entrata e uscita non hanno particolari riferimenti tra loro.

### Cuscinetti

Sono a sfere, largamente dimensionati e a gola profonda.

### Tenute lubrificante interno

Con anelli di tenuta su tutti i modelli. A richiesta sono disponibili anelli speciali per alte o basse temperature.

### Lubrificazione

I rinvii vengono forniti già equipaggiati di lubrificante: la grandezza 31 con grasso permanente; tutte le altre grandezze con olio.

## 8.1 Characteristics

### Housing

*Single-piece aluminium alloy casting with 5 mounting points and 3 flanges.*

### Gears

*Bevel gears GLEASON toothed are made of Nickel – Chrome steel and are submitted to a surface case - quench hardening treatment before the running in.*

*The backlash between gears ensures maximum service life and very low noise level. Back lash tolerances can be reduced to a minimum of 5' if specifically requested.*

### Shafts

*The shafts are made of steel with 80Kg/mm<sup>2</sup> resistance and surface treated against corrosion.*

*The external coupling is carried out by means of a key UNI standard (except for the size 1) . Keyways can be made at any angle, no special references between them are necessary.*

### Bearings

*Ball bearings liberally dimensioned and with deep races.*

### Oilseals

*Oilseal rings are fitted to all models. Special seal rings for high or low temperatures are available upon request.*

### Lubrication

*The right angle gearboxes are supplied complete with lubrication: the size 31 is filled with long life grease; the other sizes are filled with oil.*

## 8.1 Merkmale

### Gehäuse

Starres Getriebegehäuse aus Leichtmetall mit 5 Befestigungsflächen und 3 Zentriermöglichkeiten.

### Verzahnung

Die auf Gleason-Maschinen hergestellten Kegelräder sind aus Nickel-Chrome Stahl und wurden vor dem Einlaufen einsatzgehärtet. Das Zahnflankenspiel zwischen den Rädern ist für optimale Eingriffseigenschaften und Laufruhe ausgelegt, auf Wunsch kann das Spiel bis auf 5' reduziert werden.

### Wellen

Die aus speziell behandeltem Stahl mit einer Festigkeit von 80 kg/mm<sup>2</sup> gefertigten Wellen sind korrosiongeschützt.

Die Abtriebswelle ist mit Passfedernut nach UNI – Norm versehen (mit Ausnahme der Baugröße 1). Die Passfedern können jede beliebige Winkelposition einnehmen.

### Lager

Grosszügig dimensionierte Kugellager mit tiefer Laufrille.

### Dichtungen

Alle Winkelgetriebe sind mit Dichtringen versehen. Auf Anfrage sind Sonderdichtringe für hohe bzw niedrige Temperaturen lieferbar.

### Schmierung

Die Winkelgetriebe werden mit Schmiermittel geliefert. Die Baugröße 31 ist mit Lebensdauer-Fett-Schmierung gefüllt, die anderen Größen sind mit Öl geschmiert.

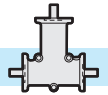

8.2 Designazione

8.2 Designation

8.2 Bezeichnung

Macchina Machine Maschine	Tipo Type Typ	Pos. alberi Shafts position Wellenposition	Rapporto rid. Ratio Unter- setzungsverhältnis	Versione Version Ausführung
<b>RL</b>	<b>32</b>	<b>AB</b>	<b>1:1</b>	<b>3FL</b>
<b>RL</b>	31 32 33 34 42	AB AC BC	1:1 2:1	3FL

Posizione alberi e sensi di rotazione

Shafts position and direction of rotation

Wellenposition und Drehrichtung

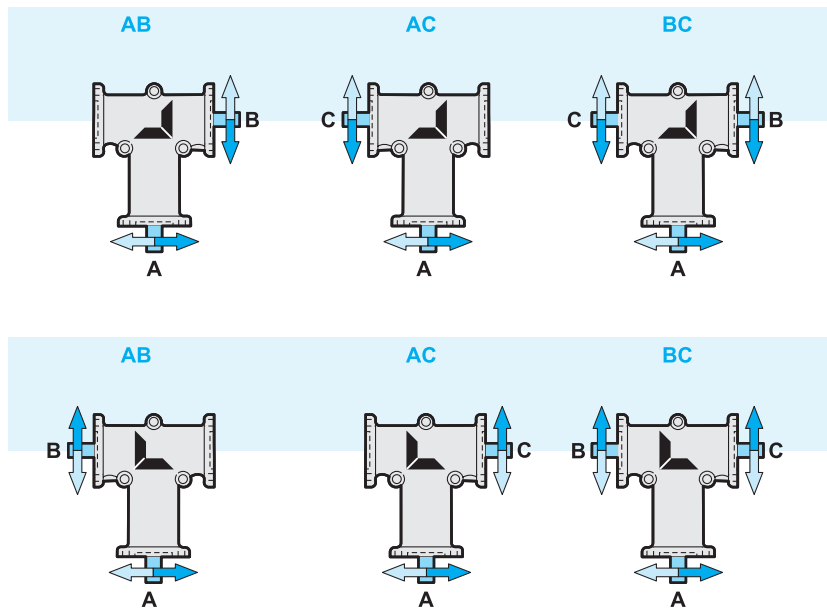

PA = albero entrata  
B = albero uscita lato corona conica  
C = albero uscita lato opposto alla corona conica

A = Input shaft  
B = Output shaft on ring bevel gear side  
C = Output shaft on opposite side to ring bevel gear

A = Antriebswelle  
B = Abtriebswelle auf Kegelschranzseite  
C = Abtriebswelle auf der gegenüberliegenden Seite des Kegelschranzes

Le figure mostrano, per ogni versione, i sensi di rotazione degli alberi.

For each version the following pictures will show the direction of rotation of the shafts

Die Abbildungen zeigen für jede Version die entsprechende Drehrichtung der Welle.

Per ogni versione, lo stesso rinvio è rappresentato in due posizioni ruotate di 180°.

The right angle gearbox is shown in two positions turned by 180°.

Für jede Version wird das gleiche Getriebe in zwei, jeweils um 180° gedrehten Positionen dargestellt.



### 8.3 Fattore di servizio FS

### 8.3 Service factor FS

### 8.3 Betriebsfactor FS

	h/d			
	3	8	12	24
<b>A</b>	0.7	0.9	1	1.3
<b>B</b>	0.9	1	1.3	1.8
<b>C</b>	1.3	1.6	1.8	2.3

**h/d**  
ore di funzionamento giornaliere  
*working hours per day*  
Tägliche Betriebszeit in Std.

**A**  
carico uniforme  
*uniform load*  
Gleichmäßiger Betrieb

**B**  
carico con urti modesti  
*load with moderate shocks*  
Mittelstarke Stöße beim Betrieb

**C**  
carico con urti  
*load with shock*  
Starke Stöße beim Betrieb

**N.B.**  
Verificare che la temperatura di esercizio non superi i valori da -20°C a +80°C.  
Nel caso del rapporto 2:1 non usare il rinvio in moltiplicazione (cioè entrando dall'albero B o C) oltre 700 giri al minuto.

**N.B.**  
*check that the operating temperature does not exceed the values -20°C / + 80°C.*  
*If you require a 2:1 ratio, do not use a speed multiplier (i.e. with inputs on shaft B or C) which operates at more than 700 rpm.*

**N.B.**  
Die Betriebstemperatur sollte nicht außerhalb des folgenden Bereichs liegen: -20°C / + 80°C.  
Falls die Getriebe als Übersetzungsgetriebe (ins Schnelle) verwendet werden sollen, ist darauf zu achten, dass die Antriebsdrehzahl an der Welle B oder C 700Upm nicht überschreiten darf.

### 8.4 Dati tecnici

### 8.4 Technical data

### 8.4 Technische Daten

n <sub>2</sub> [min <sup>-1</sup> ]	i	RL 31		RL32		RL33		RL34		RL42	
		1:1	2:1	1:1	2:1	1:1	2:1	1:1	2:1	1:1	2:1
3000	T2 [Nm]	2.0	—	7.7	—	20.2	—	33	—	5.7	—
	P1(kW)	0.63	—	2.5	—	6.5	—	11	—	1.7	—
1400	T2 [Nm]	2.4	0.9	8.6	4.2	25.2	17.9	42	29.5	8.4	6.7
	P1(kW)	0.37	0.14	1.3	0.65	3.9	2.8	6.5	4.5	1.2	0.94
1000	T2 [Nm]	2.6	1.0	9.2	4.5	27.1	19	46	33	9.8	8.0
	P1(kW)	0.29	0.11	1.0	0.50	3.0	2.1	5.1	3.6	0.98	0.80
600	T2 [Nm]	2.9	1.1	10	5	29.7	21	53	37	12.4	10.2
	P1(kW)	0.19	0.07	0.67	0.33	2.0	1.4	3.5	2.5	0.75	0.62
300	T2 [Nm]	3.4	1.3	11.6	5.6	34.7	23	63	41	16.4	13.9
	P1(kW)	0.11	0.04	0.39	0.19	1.2	0.77	2.1	1.4	0.50	0.42
100	T2 [Nm]	4.2	1.5	14.5	6.2	44	26	79	44	25.4	22
	P1(kW)	0.05	0.02	0.16	0.07	0.49	0.29	0.89	0.49	0.25	0.22
50	T2 [Nm]	4.7	1.7	16.5	6.7	50.5	27	89	46	33	25.7
	P1(kW)	0.03	0.01	0.09	0.04	0.28	0.15	0.5	0.26	0.17	0.13
Kg		0.3		1.2		3.5		5.7		2	

Simbolo Symbol Symbol	Definizione Definition	Definition
n <sub>2</sub>	Giri uscita <i>Output revs</i>	Umdrehungen Abtrieb
i	Rapporto <i>Ratio</i>	Untersetzung
T <sub>2</sub>	Coppia uscita max. <i>Max. output torque</i>	Max. Abtriebsdrehzahl
P <sub>1</sub>	Potenza entrata <i>Input power</i>	Antriebsleistung
Kg	Massa <i>Masse</i>	Masse

### 8.5 Carichi radiali e assiali (N)

### 8.5 Radial and axial loads (N)

### 8.5 Radiale und Axiale Belastungen (N)

	Fr	Fa
<b>RL31</b>	210	110
<b>RL32</b>	410	200
<b>RL33</b>	760	430
<b>RL34</b>	880	490

**Fr:**  
Carico radiale max. N applicato a metà della sporgenza dell'albero  
Max radial load in N applied mid of shaft extension  
Max. Radialbelastung in N bei der halben Länge der herausragenden Welle

**Fa:**  
Carico assiale max. N  
Max. axial load in N  
Axial - Belastung (max) in N

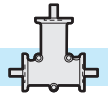

**RL 31**

**3FL**

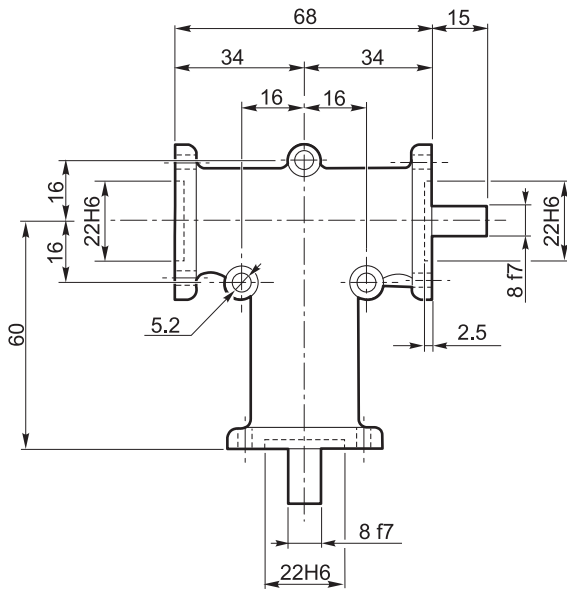

**AB**

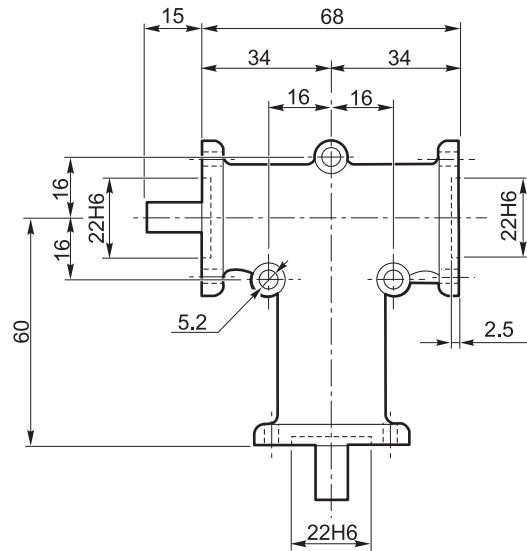

**AC**

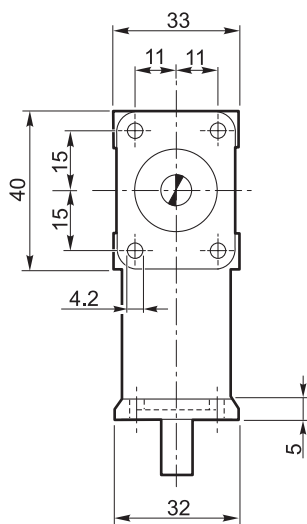

**BC**



**RL 32 - RL 33 - RL 34**

**3FL**

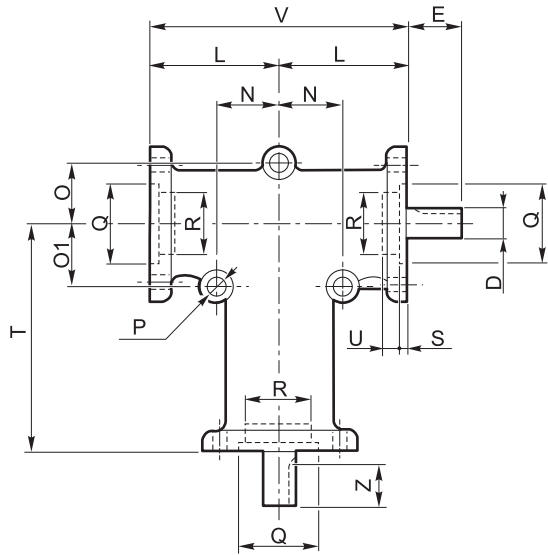

**AB**

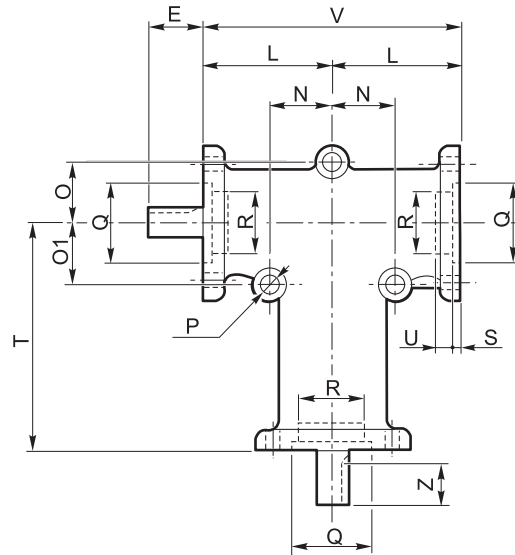

**AC**

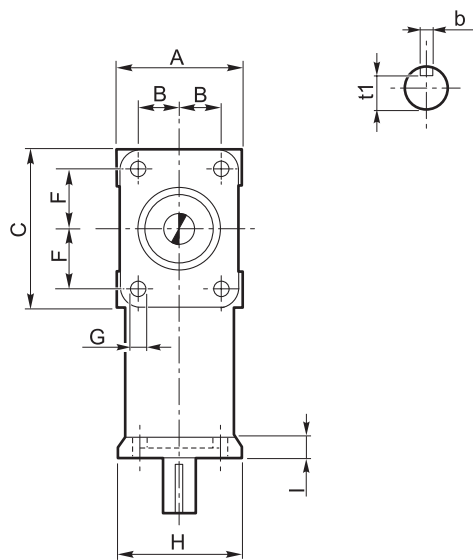

**BC**

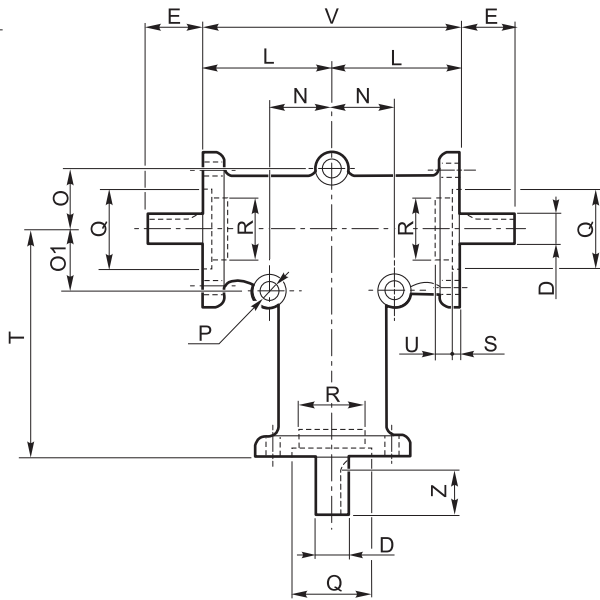

	A	B	C	D <sub>f7</sub>	b	t <sub>1</sub>	E	F	G	H	I	L	N	O	O <sub>1</sub>	P	Q <sub>H6</sub>	R <sub>H6</sub>	S	T	U	V	Z
<b>RL 32</b>	52	18	66	15	5	12	35	26	6.2	50	7	52	24	24	24	8.3	35	-	5	90	-	104	27
<b>RL 33</b>	76	27	96	20	6	16.5	50	38	8.3	74	8	75	38	38	38	8.3	55	52	3.5	140	5	150	40
<b>RL 34</b>	100	38	98	25	8	21	70	38	10.3	98	13	80	45	45	70	10.3	65	62	3.5	150	2	160	60

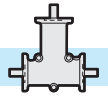

**RL 42**

**3FL**

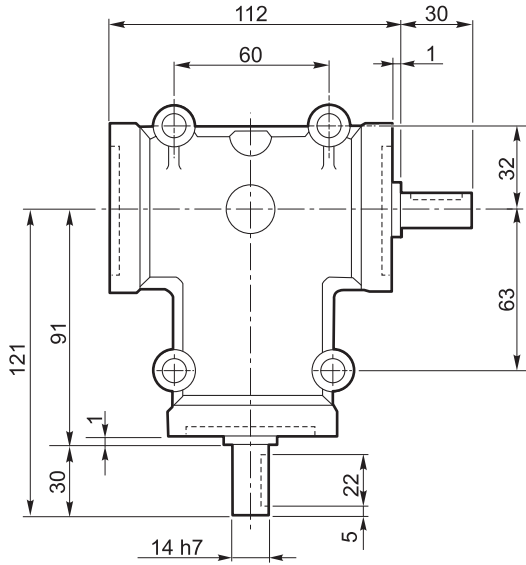

**AB**

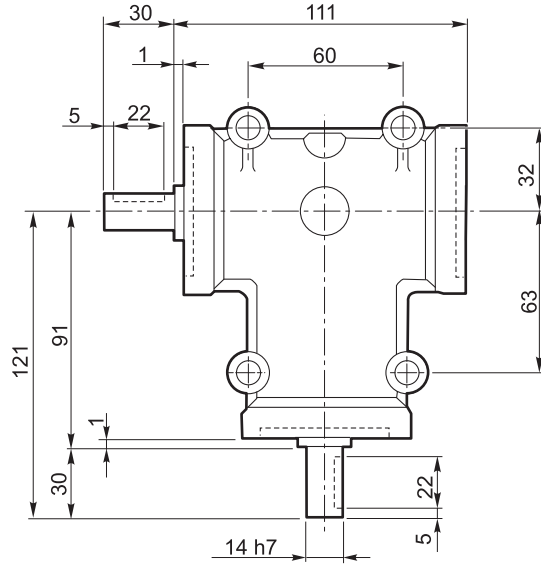

**AC**

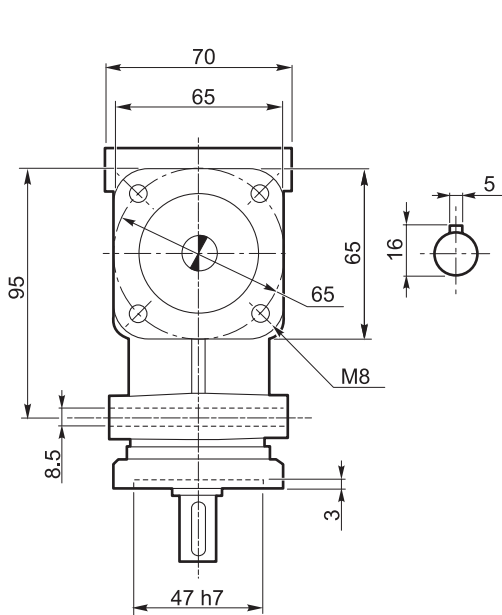

**BC**

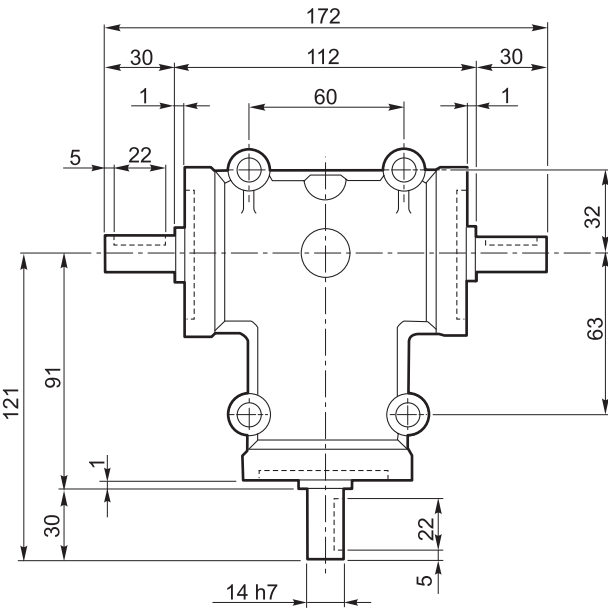



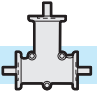

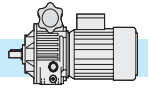

9.0	VARIATORI N	VARIATORS N	VERSTELLGETRIEBE N	
9.1	Principio di funzionamento	<i>Variator operating principle</i>	Betriebsprinzip	136
9.2	Variatori	<i>Variators</i>	Verstellgetriebe	137
9.3	Caratteristiche	<i>Features</i>	Eigenschaften	137
9.4	Designazione	<i>Designation</i>	Bezeichnung	138
9.5	Dati tecnici	<i>Technical data</i>	Technische Angaben	140
9.6	Lubrificazione	<i>Lubrication</i>	Schmierung	141
9.7	Posizioni di montaggio	<i>Mounting positions</i>	Einbaulagen	142
9.8	Dimensioni	<i>Dimensions</i>	Abmessungen	143

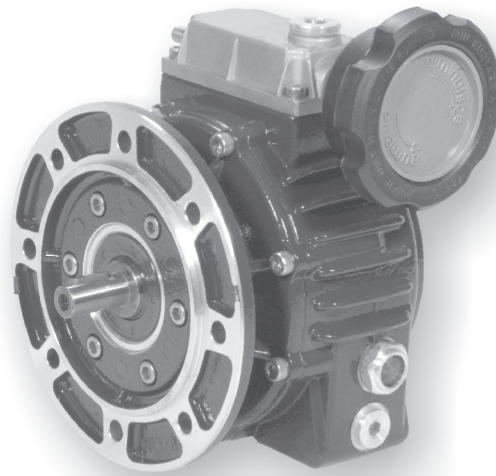

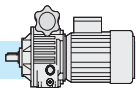

### 9.1 Principio di funzionamento del variatore

Si tratta di una trasmissione epicicloidale a rapporto variabile.

Quando il motore aziona il solare (5-6), i satelliti (8) sono indotti a ruotare sul proprio asse e, contemporaneamente, per effetto del vincolo con la pista esterna fissa (7) e la pista esterna mobile (9), ad un movimento di rivoluzione che trascina in rotazione il portasatelliti (albero uscita).

Variando la posizione assiale della pista esterna mobile (9) tramite la vite di comando, l'anello portasfere (14) e la camma fissa (15), i satelliti sono costretti a variare la loro posizione radiale di rivoluzione. In tal modo i diametri di rotolamento cambiano, così come la velocità angolare dell'albero uscita.

Quando il contatto di rotolamento con le piste esterne (7) (9) si trova verso il centro del satellite (8), la velocità di rivoluzione è più bassa: l'albero uscita ruoterà più lentamente ma avrà disponibile un maggior momento torcente.

#### Attenzione

La regolazione della velocità si può effettuare SOLO col variatore in funzione, MAI a macchina ferma.

### 9.1 Variator operating principle

*The mechanical variator is based on an epicyclic transmission for variable ratios.*

*The motor rotates the solar rings (5-6) which rotate the satellites (8). In turn these are in contact with the fixed outer ring (7) and external mobile ring (9).*

*The satellites rotate around their axes while simultaneously originate the rotation of the satellite carrier (output shaft).*

*When the rolling contact point of the outer rings (7) (9) is near the center of satellites (8) the output speed will reduce: the output shaft will rotate more slowly thus increasing the output torque value.*

#### Warning

*Speed adjustment is only possible when variator is running, never adjust speed while variator is stationary.*

*This will result in damage to the variator.*

### 9.1 Funktionsprinzip des Verstellgetriebes

Das Verstellgetriebe ist ein Planetengetriebe mit verstellbarem Untersetzungsverhältnis.

Der Motor treibt das Sonnenrad (5-6) an. Die Drehbewegung wird auf die Planetenräder (8) übertragen. Die Verbindung zwischen der unbeweglichen (7) und der beweglichen (9) äußeren Laufbahn überträgt die Drehbewegung an die Abtriebswelle.

Durch die Verschiebung des Kugelringes (14) und der Nocke (15) ändert sich die Axiallage der beweglichen Laufbahn (9) und die Radiallage der Planetenräder. Auf diese Weise ändern sich den Rollendurchmesser und die Winkelgeschwindigkeit der Abtriebswelle.

Verschiebt sich der Kontaktpunkt zwischen den Planetenrädern (7) und der äußeren Laufbahn (9) gegen das Zentrum der Planetenräder, sinkt die Ausgangsdrehzahl und das Drehmoment steigt.

#### Vorsicht

Die Geschwindigkeit darf nur verstellt werden, wenn das Verstellgetriebe im Betrieb ist und nicht wenn es still steht. Andernfalls kommt es zu einer Beschädigung des Verstellgetriebes.

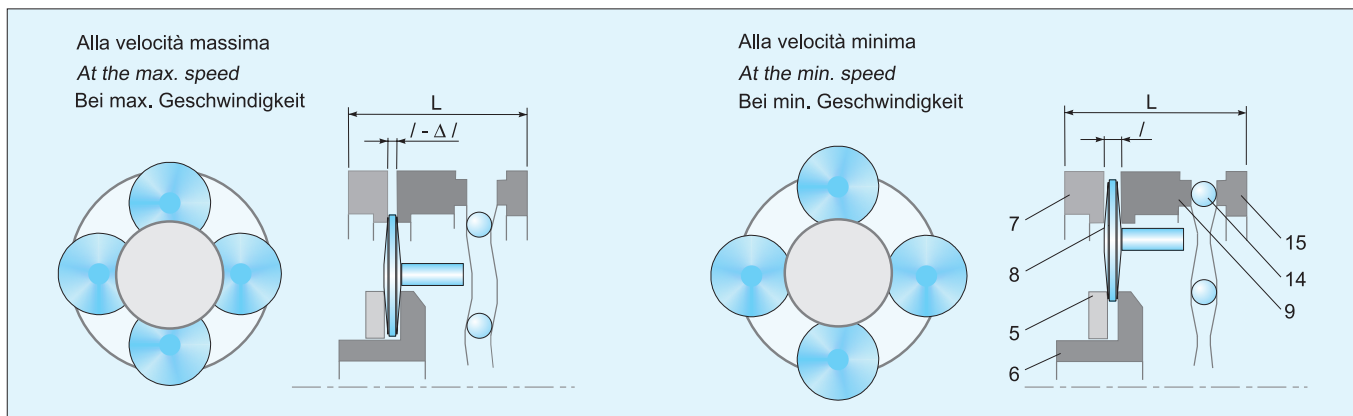

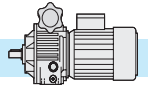

## 9.2 Variatori

I variatori meccanici serie N sono in alluminio nelle grandezze 003, 005, 010, 020, 030, 050 per potenze da 0.18 kW a 4 kW.

## 9.2 Caratteristiche

*The mechanical variators N Series size 003, 005, 010, 020, 030, and 050 power range 0.18 kW to 4kW are manufactured in aluminium.*

## 9.2 Merkmale

Die mechanischen Verstellgetriebe Serie N in den Größen 003, 005, 010, 020, 030 und 050 für Leistungen von 0.18kW bis 4kW, sind aus Aluminium gefertigt.

## 9.3 Caratteristiche

- La carcassa in alluminio, oltre ad una migliore estetica, comporta un minor peso del variatore rendendone più convenienti applicazioni e trasporti.
- Sul modulo base è possibile montare, in modo semplice e veloce, flangia uscita o piede, a seconda delle necessità. Questo riduce i volumi di stoccaggio ed i tempi di consegna.
- Il lato di entrata del variatore è chiuso, parte integrale col corpo: questo rende più facile l'installazione ed elimina totalmente la possibilità di perdite d'olio.
- È previsto, come standard, il collegamento a motori a dimensioni IEC forma B5.
- Il tappo di scarico olio è del tipo a magnete: la lubrificazione più pulita consente intervalli di manutenzione più lunghi.
- Funzionamento in bagno d'olio, silenzioso, con elevato rendimento ed esente da vibrazioni.
- Il funzionamento è possibile in entrambi i sensi di rotazione con entrata ed uscita concordi.
- Campo di variazione 1 - 6.
- L'albero di comando è bisporgente ed è quindi accessibile, per la manovra, da entrambe le estremità.

## 9.3 Characteristics

- *The aluminium housing benefits weight reduction for more convenient applications and transportation.*
- *The simple design allows both foot or flange mounting to standard unit, reducing stocking levels and allowing quick delivery.*
- *The closed input flange is an integral part of the variator casing for easy installation and prevents possibility of oil leaks.*
- *IEC B5 motor connections available as standard.*
- *The magnetic breather plug maintains a clean lubricant and extends maintenance intervals.*
- *The oil bath operation provides high efficiency for noiseless and vibration free running.*
- *The unit can operate in both directions, input and output shafts rotate in the same direction.*
- *Range of variation 1 - 6.*
- *The double extended drive shaft allows easy installation from both sides.*

## 9.3 Merkmale

- Dank dem Gehäuse aus Aluminium ist das Verstellgetriebe sehr leicht, was zur erleichterten Anwendung und Transport dient.
- Auf das Grundmodul können entweder Abtriebsflansch oder Fuß montiert werden. Das bringt Raumersparnis und schnellere Lieferzeit mit sich.
- Die Antriebsseite ist geschlossen und integrales Bestandteil des Gehäuses: Installation ist einfacher und Ölverluste sind ausgeschlossen.
- Standard-Anbau zu IEC B5 Motoren.
- Magnet-Ölablassschraube: die reinigere Schmierung erlaubt längere Wartungsintervalle.
- Betrieb im Ölbad ist geräuschlos, mit erhöhter Leistung und vibrationsfrei.
- Betrieb ist in beide Drehrichtungen möglich, mit Antriebs- und Abtriebswellen in derselber Richtung drehend.
- Verstellbereich 1 – 6.
- Die Welle für das Steuer-Handrad ist beidseitig herausgeführt, sodass es von beiden Seiten bedient werden kann.

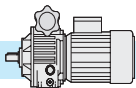

9.4 Designazione

9.4 Designation

9.4 Bezeichnung

Tipo Type Typ	Grandezza Size Größe	Albero uscita diam. mm Output shaft diam. mm Abtriebswelle Durchmesser mm	Flangia uscita diam. mm Output flange diam. mm Abtriebsflansch Durchmesser mm	Attacco motore IEC IEC motor adaptor IEC Motoranbau	Posizione di montaggio Mounting position Einbaulage	Posizione scatola di comando Speed control box position Lage des Steuerkastens	Potenza motore Motor power Motorleistung	N° poli Poles number Polzahl	Forma costruttiva motore Motor version Motorversion	Tensione Voltage Spannung	Frequenza Frequency Frequenz	Posizione morsettiere Terminal box position Lage des Klemmkastens
<b>NF</b>	<b>030</b>	<b>AU28</b>	<b>F250</b>	<b>100B5</b>	<b>B5</b>	<b>SA</b>	<b>2.2 kW</b>	<b>4</b>	<b>B5</b>	<b>230/400</b>	<b>50Hz</b>	<b>MA</b>
<b>N</b> <b>NM</b> <b>NF</b> <b>NK</b> <b>NMK</b> <b>NFK</b>	<b>003</b> <b>005</b> <b>010</b> <b>020</b> <b>030</b> <b>050</b>	Vedi tabelle  <i>See tables</i>  Siehe Tabelle	Vedi tabelle  <i>See tables</i>  Siehe Tabelle	Vedi tabelle  <i>See tables</i>  Siehe Tabelle	<b>B3</b> <b>B6</b> <b>B7</b> <b>B8</b> <b>V5</b> <b>V6</b> <b>B5</b> <b>V1</b> <b>V3</b>	<b>SA</b> <b>SB</b> <b>SC</b> <b>SD</b>	Vedi tabelle  <i>See tables</i>  Siehe Tabelle	<b>2</b> <b>4</b> <b>6</b>	<b>B5</b>			<b>MA</b> <b>MB</b> <b>MC</b> <b>MD</b>

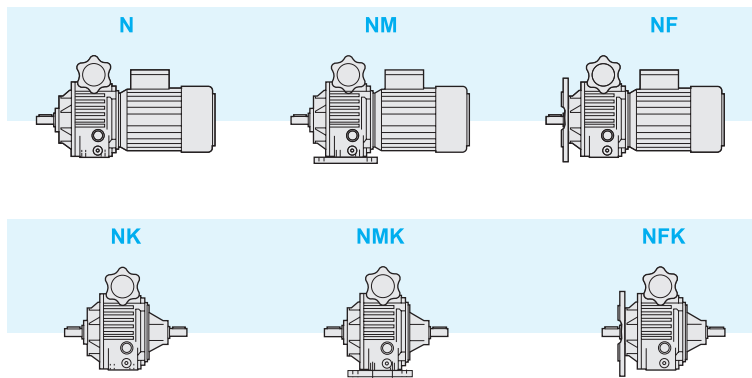

Posizione morsettiere e scatola di comando

Terminal box and speed control box position

Lage des Klemmkastens und des Steuerkastens

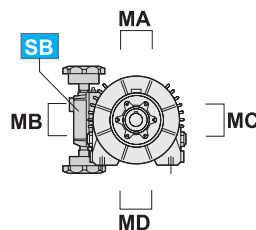
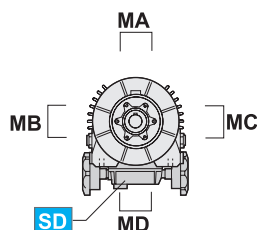
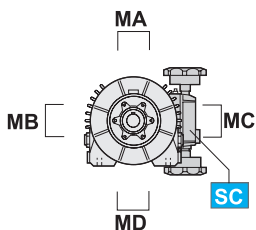
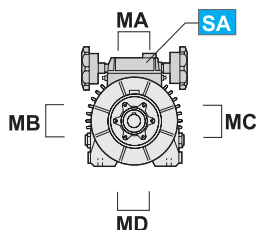

MA, MB, MC, MD  
Posizione morsettiere  
Terminal box position  
Lage des Klemmkastens

SA, SB, SC, SD  
Posizione scatola di comando  
Speed control box position  
Lage des Steuerkastens

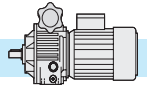

9.4 Designazione

9.4 Designation

9.4 Bezeichnung

Tipo Type Typ	Grandezza Size Größe	Rapporto di riduzione (i) Reduction ratio (i) Untersetzungsverhältnis	Albero uscita diam. mm Output shaft diam. mm Abtriebswelle Durchmesser mm	Flangia uscita diam. mm Output flange diam. mm Abtriebsflansch Durchmesser mm	Attacco motore IEC IEC motor adaptor IEC Motoranbau	Posizione di montaggio Mounting position Einbaulage	Posizione scatola di comando Speed control box position Lage des Steuerkastens	Potenza motore Motor power Motorleistung	N° poli Poles number Polzahl	Forma costruttiva motore Motor version Motorversion	Tensione Voltage Spannung	Frequenza Frequency Frequenz	Posizione morsetti Terminal box position Lage des Klemmkastens
<b>NFR</b>	<b>003/1</b>	<b>5</b>	<b>AU19</b>	<b>F160</b>	<b>63B5</b>	<b>B5</b>	<b>SA</b>	<b>0.25 kW</b>	<b>4</b>	<b>B5</b>	<b>230/400</b>	<b>50Hz</b>	<b>MA</b>
<b>NRT</b> <b>NRM</b> <b>NRF</b> <b>NRTK</b> <b>NRMK</b> <b>NRFK</b>	<b>003/1</b> <b>005/1</b> <b>010/1</b> <b>020/1</b> <b>030/1</b> <b>050/1</b>	<b>2.5</b> <b>5</b>	Vedi tabelle  <i>See tables</i>  Siehe Tabelle	Vedi tabelle  <i>See tables</i>  Siehe Tabelle	Vedi tabelle  <i>See tables</i>  Siehe Tabelle	<b>B3</b> <b>B6</b> <b>B7</b> <b>B8</b> <b>V5</b> <b>V6</b> <b>B5</b> <b>V1</b> <b>V3</b>	<b>SA</b> <b>SB</b> <b>SC</b> <b>SD</b>	Vedi tabelle  <i>See tables</i>  Siehe Tabelle	<b>2</b> <b>4</b> <b>6</b>	<b>B5</b>			<b>MA</b> <b>MB</b> <b>MC</b> <b>MD</b>

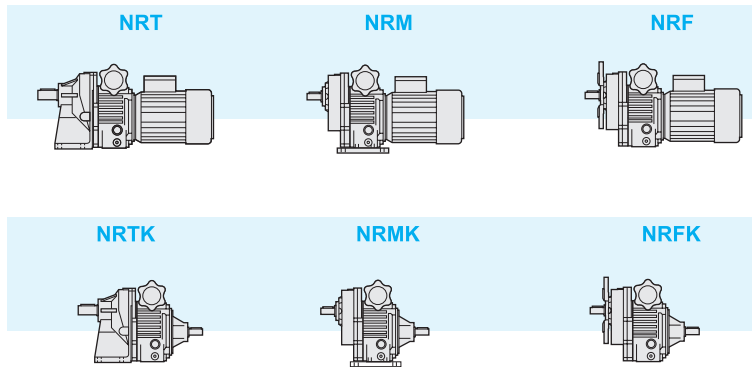

Posizione morsetti  
e scatola di comando

Terminal box and speed  
control box position

Lage des Klemmkastens und des  
Steuerkastens

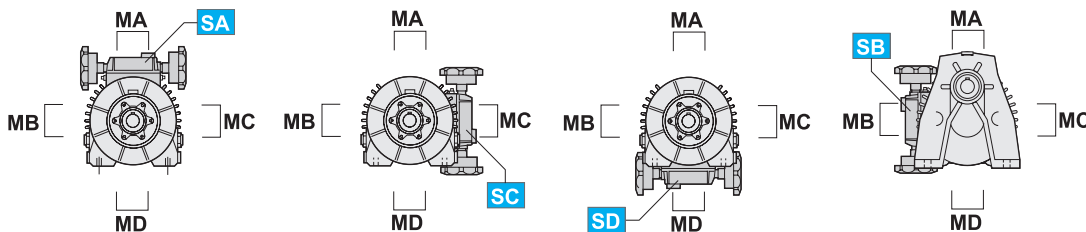

MA, MB, MC, MD  
Posizione morsetti  
Terminal box position  
Lage des Klemmkastens

SA, SB, SC, SD  
Posizione scatola di comando  
Speed control box position  
Lage des Steuerkastens

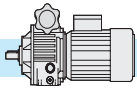

9.5 Dati tecnici

9.5 Technical data

9.5 Technische Angaben

Tipo Type Typ	P <sub>1</sub> kW	Poli Poles Polen	Attacco motore IEC IEC motor adaptor IEC Motoranbau	n <sub>2</sub> max min <sup>-1</sup>	n <sub>2</sub> min min <sup>-1</sup>	i	T <sub>2</sub> min Nm	T <sub>2</sub> max Nm
N003	0.25	4	63 B5	950	190	—	1.9	3.8
	0.37	2	63 B5	1900	380	—	1.5	3
NR 003/1	0.25	4	63 B5	380	76	2.5	4.7	9.3
				190	38	5	9.3	18.6
N005	0.37	4	71 B5	1000	167	—	3	6
	0.55	4	71 B5	1000	167	—	4.5	9
	0.75	2	71 B5	2000	333	—	3	6
NR 005/1	0.37	4	71 B5	400	67	2.5	7.3	14.7
				200	33	5	14.7	29.4
N010	0.75	4	80 B5	1000	167	—	6	12
	0.92	4	80 B5	1000	167	—	7.5	12
	1.5	2	80 B5	2000	333	—	6	12
NR 010/1	0.75	4	80 B5	400	67	2.5	14.7	29.4
				200	33	5	29.4	58.8
N020	1.5	4	90 B5	1000	167	—	12	24
	1.85	4	90 B5	1000	167	—	15	24
	2.2	2	90 B5	2000	333	—	9	18
NR 020/1	1.5	4	90 B5	400	67	2.5	29.4	58.8
				200	33	5	58.8	118
N030	2.2	6	100 B5	660	125	—	27	54
	2.2	4	100 B5	1000	167	—	18	36
	3	4	100 B5	1000	167	—	24	48
NR 030/1	2.2	4	100 B5	400	67	2.5	44.1	88.2
				200	33	5	88.2	176
N050	4	4	112 B5	1000	167	—	32	64
NR 050/1	4	4	112 B5	400	67	2.5	78.4	157
				200	33	5	157	314

Simbologia:

**P<sub>1</sub>** [kW] Potenza motore  
**poli** N° poli motore  
**n<sub>2</sub> max** [min<sup>-1</sup>] Velocità massima in uscita  
**n<sub>2</sub> min** [min<sup>-1</sup>] Velocità minima in uscita  
**T<sub>2</sub> min** [Nm] Coppia alla velocità massima  
**T<sub>2</sub> max** [Nm] Coppia alla velocità minima  
**i** Rapporto di riduzione

Symbols:

**P<sub>1</sub>** [kW] Motor power  
**poles** Number of poles  
**n<sub>2</sub> max** [min<sup>-1</sup>] Max output speed  
**n<sub>2</sub> min** [min<sup>-1</sup>] Min output speed  
**T<sub>2</sub> min** [Nm] Output torque at the high speed  
**T<sub>2</sub> max** [Nm] Output torque at the low speed  
**i** Reduction ratio

Symbole:

**P<sub>1</sub>** [kW] Motorleistung  
**poli** Motor Polzahl  
**n<sub>2</sub> max** [min<sup>-1</sup>] Max Abtriebsdrehzahl  
**n<sub>2</sub> min** [min<sup>-1</sup>] Min. Abtriebsdrehzahl  
**T<sub>2</sub> min** [Nm] Drehmoment bei max. Drehzahl  
**T<sub>2</sub> max** [Nm] Drehmoment bei min. Drehzahl  
**i** Untersetzungsverhältnis

Il diagramma A riporta i valori indicativi del rendimento del variatore alle varie velocità in uscita n<sub>2</sub> espresse in min<sup>-1</sup> e il diagramma B indica la percentuale di carico sul motore.

Diagram A shows the indicative value of efficiency in relation to output speed n<sub>2</sub> expressed in min<sup>-1</sup>. Diagram B shows the percentage of motor output power utilized.

Diagramm A zeigt die Richtwerte des Wirkungsgrads in Abhängigkeit zur n<sub>2</sub> in min<sup>-1</sup>. Diagramm B zeigt den Prozentsatz der abgegebenen Motorleistung.

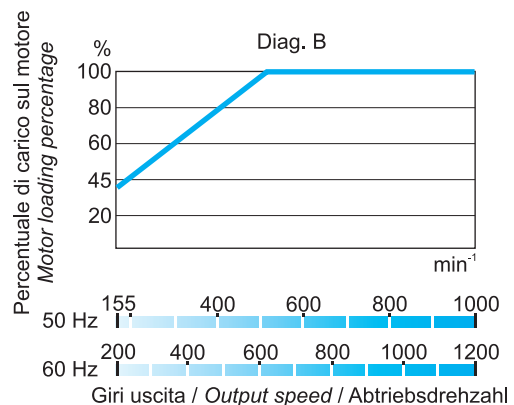
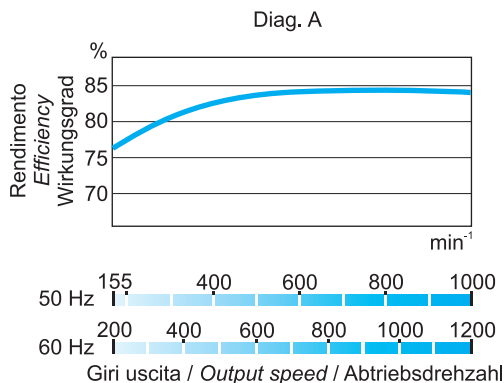

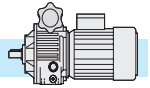

I diagrammi seguenti riportano le curve di coppia riferite alle varie potenze applicate e al numero di giri in entrata al variatore  $n_1$  ( $\text{min}^{-1}$ ).

The following diagrams show the performance for output torque in relation to input power and input speed  $n_1$  ( $\text{min}^{-1}$ ).

Die folgenden Diagramme zeigen die Drehmomentkurven bezüglich Leistung und Antriebsdrehzahl.

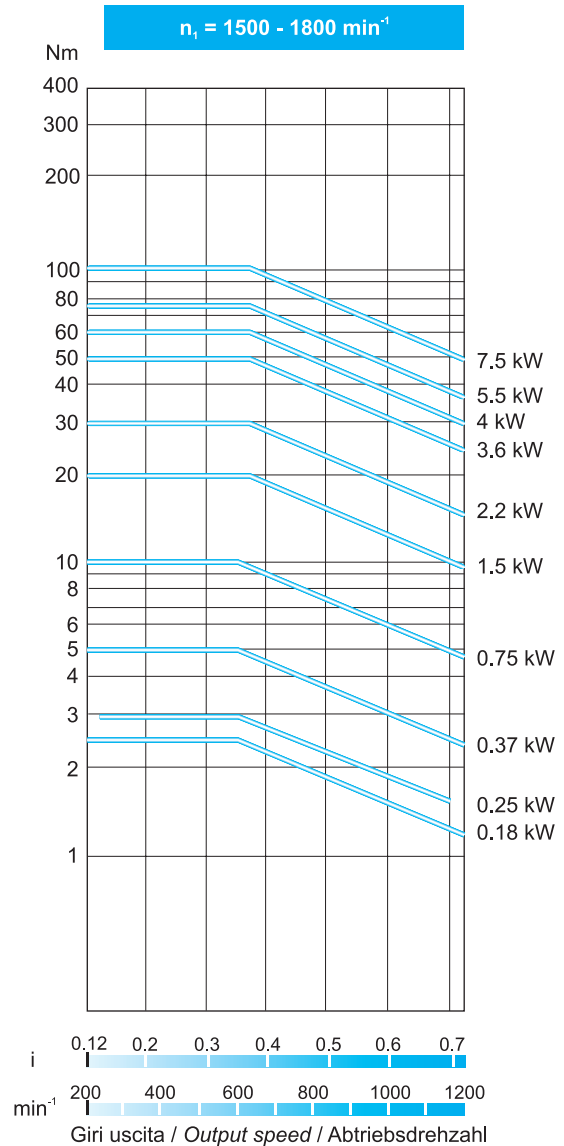
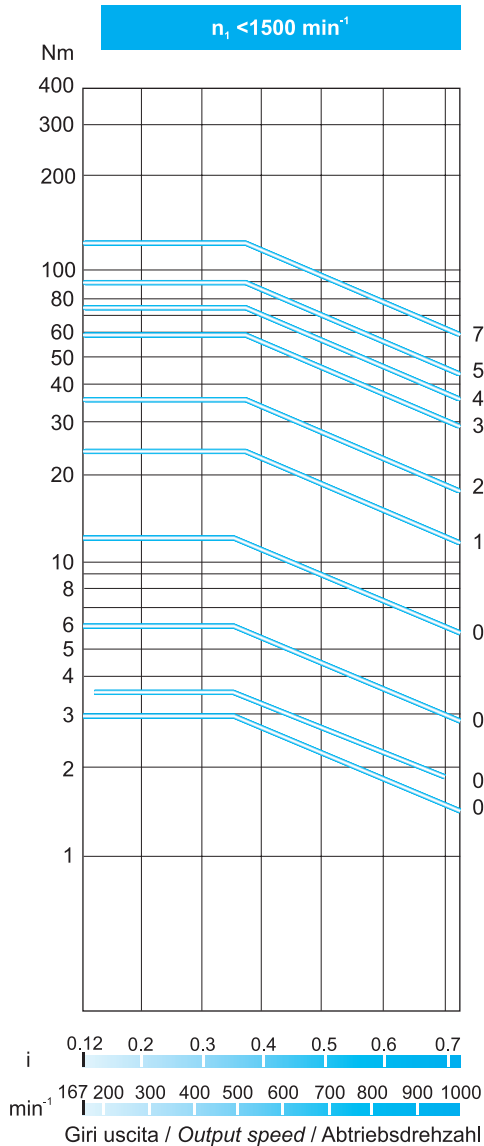

### 9.6 Lubrificazione

I variatori vengono forniti completi di lubrificante. Dopo il piazzamento del variatore assicurarsi che il livello del lubrificante sia visibile dall'apposita spia di livello effettuando eventuali rabbocchi se necessario, con un analogo lubrificante scelto fra quelli raccomandati in tabella.

### 9.6 Lubrification

The variators are supplied complete with lubricant. After the mounting pls make sure the oil can be seen through the oil level plug this to allow the filling up if necessary. Oil has to be selected among the recommended ones.

### 9.6 Schmierung

Die Verstellgetriebe werden mit Schmiermittel geliefert. Nach Einbau des Verstellgetriebes ist der Ölstand durch das Schauglas zu prüfen. Wenn nötig, füllen Sie mit einem der empfohlenen Öle auf (siehe Tabelle).

Tipi di lubrificanti raccomandati / Recommended lubricants / Empfohlene Öle			
Dexron fluid II	IP		
A.T.F. Dexron fluid DIII	SHELL		
A.T.F. 200 RED	MOBIL		
A.T.F. Dexron	FINA		
BP Autran DX	BP		
A.T.F. Dexron	ESSO		
A.T.F. Dexron	CHEVRON		
A.T.F. Dexron	AGIP		
		Atina grease 0	IP
		Tivela Compound A	SHELL



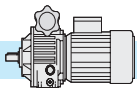

9.7 Posizioni di montaggio

9.7 Mounting positions

9.7 Einbaulagen

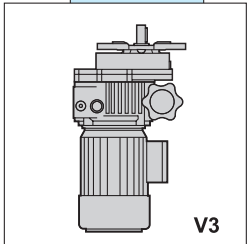
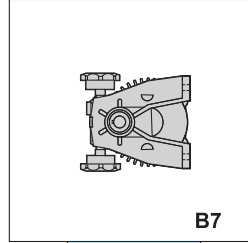
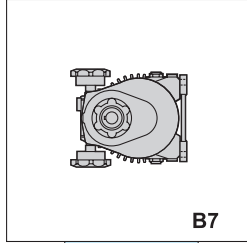
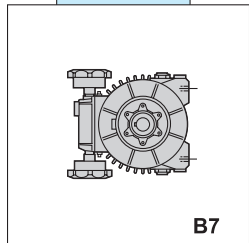
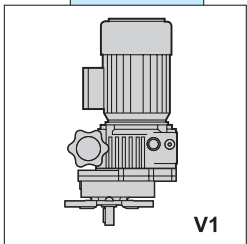
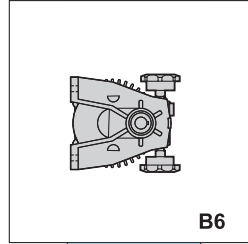
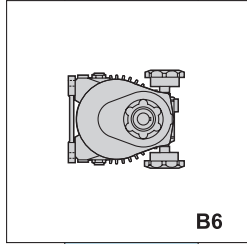
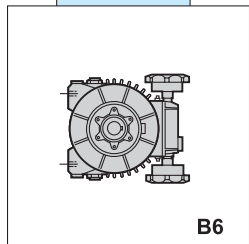
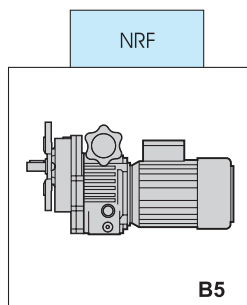
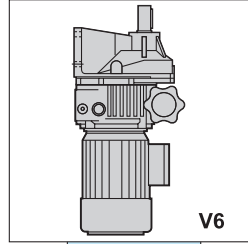
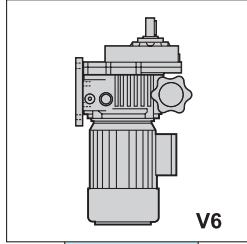
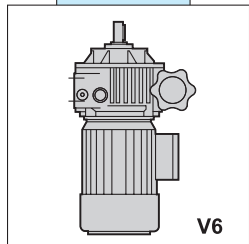
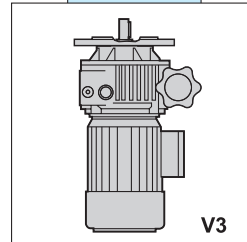
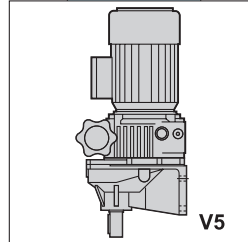
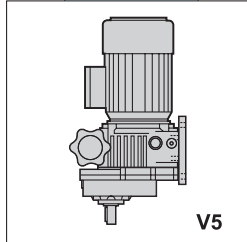
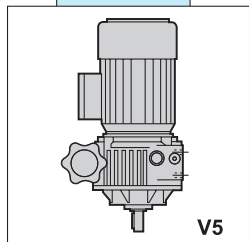
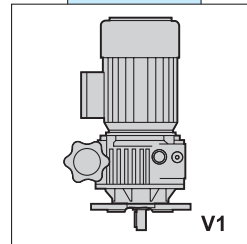
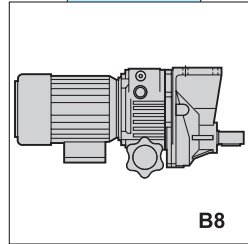
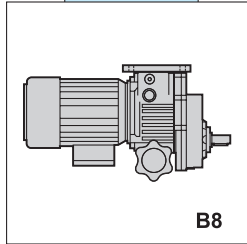
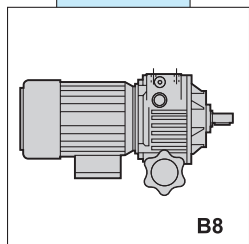
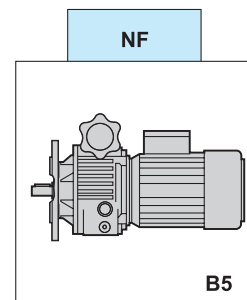
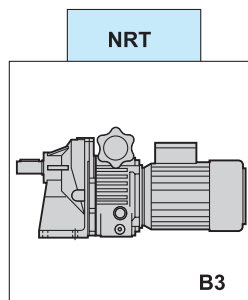
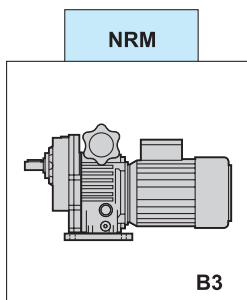
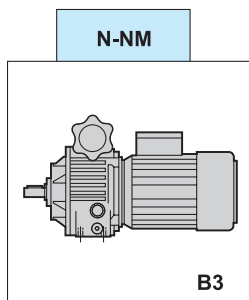

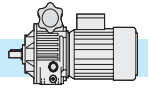

9.8 Dimensioni

9.8 Dimensions

9.8 Abmessungen

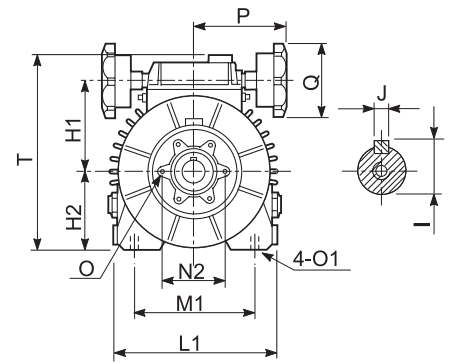
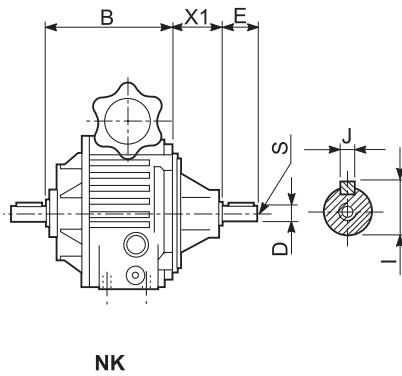
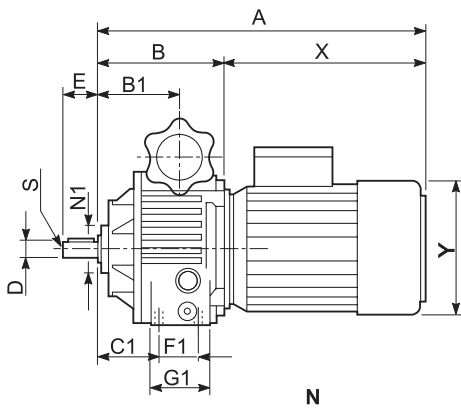

Tipo Type Typ	A	B	B1	C1	D	E	F1	G1	H1	H2	I	J	L1	M1	N1	N2	O	O1	P	Q	S	T	X	X1	Y	Kg
<b>N003</b>	302	110	66	44	11	23	36	55	79	58	12.5	4	128	100	42	56	M6	M8	97	89	M5	160	192	42	122	5
<b>N005</b>	336	118	78	61	14	30	36	55	88	73	16	5	153	120	56	75	M6	M8	97	89	M6	185	218	50	137	7
<b>N010</b>	383	145	95	75	19	40	45	82	107	91	21.5	6	187	140	56	75	M6	M10	107	89	M6	222	239	65	158	13
<b>N020</b>	450	172	105	82	24	50	58	82	126	108	27	8	220	190	75	100	M8	M10	107	89	M8	264	278	70	177	20

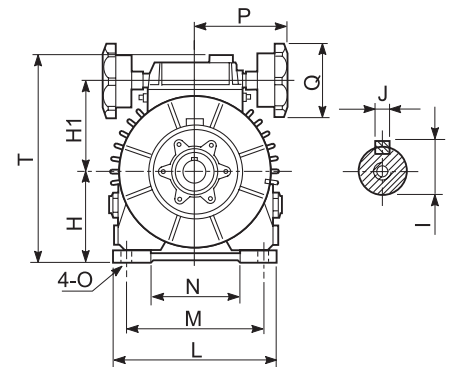
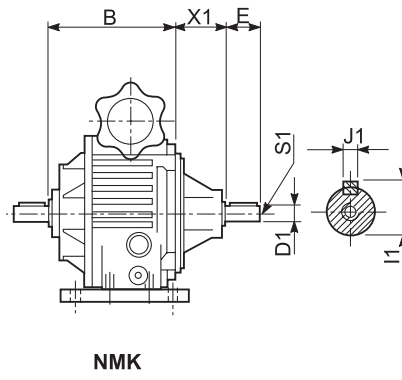
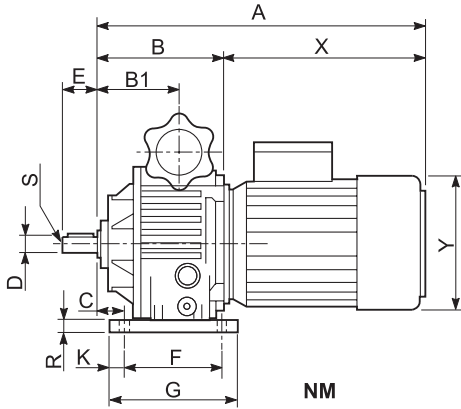

Tipo Type Typ	A	B	B1	C	D	D1	E	F	G	H	H1	I	I1	J	J1	K	L	M	N	O	P	Q	R	S	S1	T	X	X1	Y	Kg
<b>NM003</b>	302	110	66	25	11 (14)	11	23 (30)	105	130	71	76	12.5 (16)	12.5	4 (5)	4	12.5	140	110	80	9	97	89	11	M5 (M6)	M5	173	192	42	122	6
<b>NM005</b>	336	118	78	30	14 (19)	14	30 (40)	105	130	90	88	16 (21.5)	16	5 (6)	5	12.5	155	120	83	10	97	89	13	M6	M6	202	218	50	137	8
<b>NM010</b>	382	143	95	35	19 (24)	19	40 (50)	125	150	106	107	21.5 (27)	21.5	6 (8)	6	12.5	190	160	120	12	107	89	13.5	M6 (M8)	M6	242	239	65	158	14
<b>NM020</b>	441	171	104	50	24 (28)	24	50 (60)	140	165	125	126	27 (31)	27	8	8	12.5	230	180	130	12	107	89	16	M8 (M10)	M8	277	270	70	177	21
<b>NM030/050</b>	546	206	122	25	28 (38)	28	60 (80)	230	270	150	158	31 (41)	31	8 (10)	8	20	300	245	190	14	155	120	20	M10 (M12)	M10	337	340	95	197	51

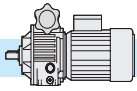

9.8 Dimensioni

9.8 Dimensions

9.8 Abmessungen

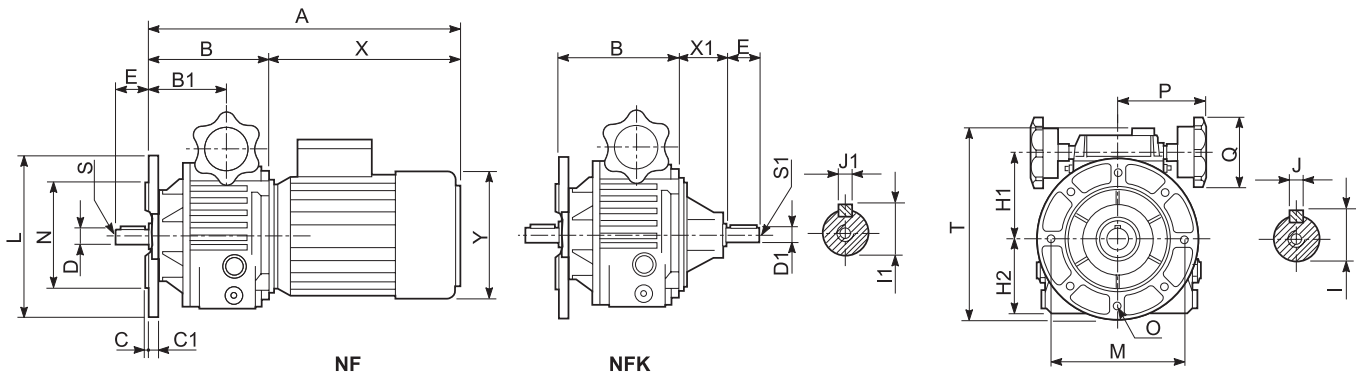

Tipo Type Typ	A	B	B1	C	C1	D	D1	E	H1	H2	I	I1	J	J1	L	M	N	O	P	Q	S	S1	T	X	X1	Y	Kg
NF003	302	110	66	3.5	8	11 (14)	11	23 (28)	76	58	12.5 (16)	12.5	4 (5)	4	140 (160)	115 (130)	95 (110)	9 (9)	97	89	M5	M5	165 (175)	192	42	122	6
NF005	338	120	80	3.5	10.5	14 (19)	14	28 (38)	88	73	16 (21.5)	16	5 (6)	5	160 (200)	130 (165)	110 (130)	9 (11)	97	89	M6	M6	188 (208)	218	50	137	8
NF010	384	145	97	3.5	13.5	19 (24)	19	38 (48)	107	91	21.5 (27)	21.5	6 (8)	6	200	165	130	11	107	89	M6 (M8)	M6	237	239	65	158	14
NF020	443	173	106	4	14	24 (28)	24	48 (58)	126	108	27 (31)	27	8	8	200 (250)	165 (215)	130 (180)	11 (14)	107	89	M8 (M10)	M8	260 (277)	270	70	177	21
NF030/050	548	208	124	4(5)	16	28 (38)	28	58 (78)	158	134	31 (41)	31	8 (10)	8	250 (300)	215 (265)	180 (230)	14	155	120	M10 (M12)	M10	336	340	95	197	51

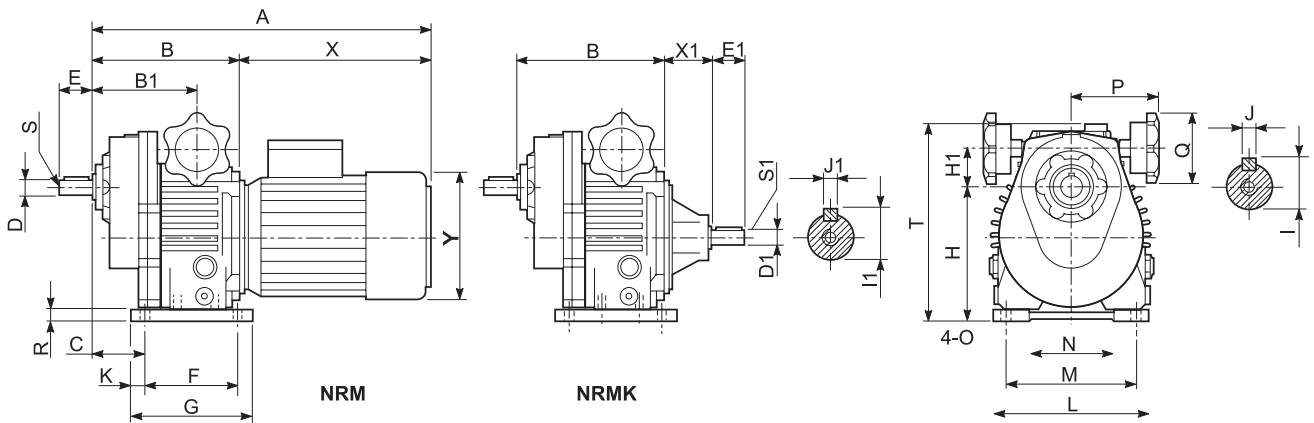

Tipo Type Typ	A	B	B1	C	D	D1	E	E1	F	G	H	H1	I	I1	J	J1	K	L	M	N	O	P	Q	R	S	S1	T	X	X1	Y	Kg
NRM003	331	139	108	57	19 (20)	11	30	23	105	130	111 (116)	36	21.5 (22.5)	12.5	6	4	12.5	140	110	80	9	97	89	11	M6	M5	173	192	42	122	7
NRM005	363	145	105	54	19 (20)	14	30	30	105	130	140 (135)	38	21.5 (22.5)	16	6	5	12.5	155	120	83	10	97	89	13	M6	M6	202	218	50	137	11
NRM010	418	179	131	69	24 (25)	19	35	40	125	150	169 (160)	44	27 (28)	21.5	8	6	12.5	190	160	120	12	107	89	13.5	M8	M6	242	239	65	158	9
NRM020	471	201	135	78	28 (30)	24	45	50	140	165	188 (190)	63	31 (33)	27	8	8	12.5	230	180	130	12	107	89	16	M10	M8	277	270	70	177	33
NRM030 NRM050	586	246	165	63	38 (40)	28	60	60	230	270	230 (224)	78	41 (43)	31	10 (12)	8	20	300	245	190	14	155	120	20	M12	M8	337	340	95	197	75

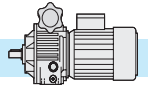

9.8 Dimensioni

9.8 Dimensions

9.8 Abmessungen

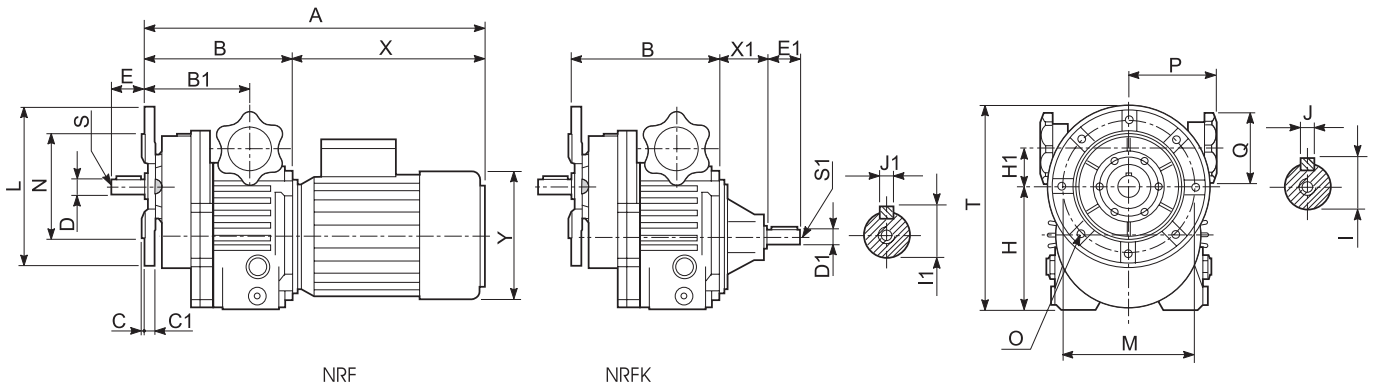

Tipo Type Typ	A	B	B1	C	C1	D	D1	E	E1	H	H1	I	I1	J	J1	L	M	N	O	P	Q	S	S1	T	X	X1	Y	Kg
<b>NRF003</b>	333	141	112	3.5	8	19	11	28	23	98	36	21.5	12.5	6	4	160	130	110	9	97	89	M6	M5	178	192	42	122	7
<b>NRF005</b>	372	154	114	3.5	10.5	19	14	28	30	123	38	21.5	16	6	5	160	130	110	9	97	89	M6	M6	203	218	50	137	11
<b>NRF010</b>	419	180	130	3.5	13.5	24	19	33	40	154	44	27	21.5	8	6	200	165	130	11	107	89	M8	M6	254	239	65	158	19
<b>NRF020</b>	473	203	137	4	14	28	24	43	50	171	63	31	27	8	8	250	215	180	14	107	89	M10	M8	296	270	70	177	33
<b>NRF030/050</b>	588	248	167	4	16	38	28	58	60	214	78	41	31	10	8	300	265	230	14	155	120	M12	M8	364	340	95	197	75

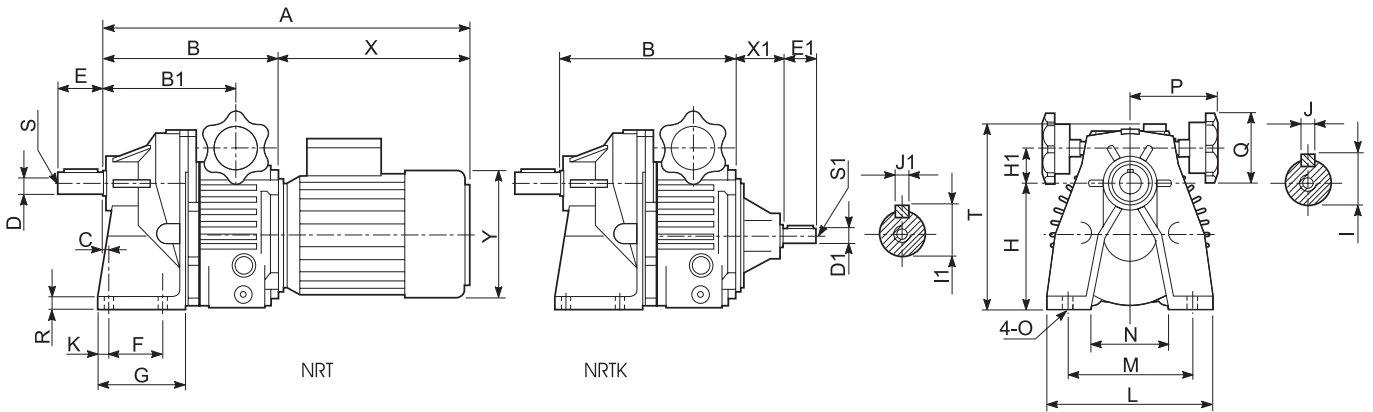

Tipo Type Typ	A	B	B1	C	D	D1	E	E1	F	G	H	H1	I	I1	J	J1	K	L	M	N	O	P	Q	R	S	S1	T	X	X1	Y	Kg
<b>NRT003</b>	376	184	140	20	19	11	40	23	45	80	110	36	21.5	12.5	6	4	14	130	105	70	9	97	89	10	M6	M5	167	192	42	122	9
<b>NRT005</b>	412	194	154	6	24	14	50	30	70	110	130	38	27	16	8	5	15	180	150	90	11	97	89	12	M8	M6	192	218	50	137	13
<b>NRT010</b>	456	218	171	7.5	28	19	60	40	70	115	163	44	31	21.5	8	6	14	215	165	100	11	107	89	15	M8	M6	231	239	65	158	21
<b>NRT020</b>	551	281	215	25	38	24	70	50	85	142	195	46	41	27	10	8	23	250	185	130	14	107	120	16	M10	M8	266	270	70	177	33
<b>NRT030/050</b>	686	346	261	19	48	28	100	60	130	178	250	59	51.5	31	14	8	17	310	240	160	17	155	120	18	M10	M8	337	340	95	197	75

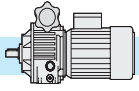

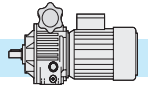

## 10.0

### VARIATORI UDL

### VARIATORS UDL

### VERSTELLGETRIEBE UDL

10.1	Principio di funzionamento	<i>Variator operating principle</i>	Betriebsprinzip	148
10.2	Variatori	<i>Variators</i>	Verstellgetriebe	149
10.3	Caratteristiche	<i>Features</i>	Eigenschaften	149
10.4	Designazione	<i>Designation</i>	Bezeichnung	150
10.5	Dati tecnici	<i>Technical data</i>	Technische Angaben	150
10.6	Lubrificazione	<i>Lubrication</i>	Schmierung	150
10.7	Posizioni di montaggio	<i>Mounting positions</i>	Einbaulagen	151
10.8	Dimensioni	<i>Dimensions</i>	Abmessungen	151

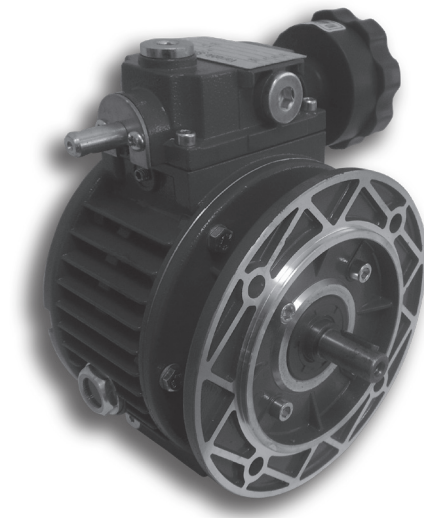

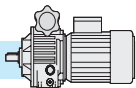

### 10.1 Principio di funzionamento del variatore

Si tratta di una trasmissione epicicloidale a rapporto variabile.

Quando il motore aziona il solare (5-6), i satelliti (8) sono indotti a ruotare sul proprio asse e, contemporaneamente, per effetto del vincolo con la pista esterna fissa (7) e la pista esterna mobile (9), ad un movimento di rivoluzione che trascina in rotazione il portasatelliti (albero uscita).

Variando la posizione assiale della pista esterna mobile (9) tramite la vite di comando, l'anello portasfere (14) e la camma fissa (15), i satelliti sono costretti a variare la loro posizione radiale di rivoluzione. In tal modo i diametri di rotolamento cambiano, così come la velocità angolare dell'albero uscita.

Quando il contatto di rotolamento con le piste esterne (7) (9) si trova verso il centro del satellite (8), la velocità di rivoluzione è più bassa: l'albero uscita ruoterà più lentamente ma avrà disponibile un maggior momento torcente.

#### Attenzione

La regolazione della velocità si può effettuare SOLO col variatore in funzione, MAI a macchina ferma.

### 10.1 Variator operating principle

*The mechanical variator is based on an epicyclic transmission for variable ratios.*

*The motor rotates the solar rings (5-6) which rotate the satellites (8). In turn these are in contact with the fixed outer ring (7) and external mobile ring (9).*

*The satellites rotate around their axes while simultaneously originate the rotation of the satellite carrier (output shaft).*

*When the rolling contact point of the outer rings (7) (9) is near the center of satellites (8) the output speed will reduce: the output shaft will rotate more slowly thus increasing the output torque value.*

#### Warning

*Speed adjustment is only possible when variator is running, never adjust speed while variator is stationary.*

*This will result in damage to the variator.*

### 10.1 Funktionsprinzip des Verstellgetriebes

Das Verstellgetriebe ist ein Planetengetriebe mit verstellbarem Untersetzungsverhältnis.

Der Motor treibt das Sonnenrad (5-6) an. Die Drehbewegung wird auf die Planetenräder (8) übertragen. Die Verbindung zwischen der unbeweglichen (7) und der beweglichen (9) äußeren Laufbahn überträgt die Drehbewegung an die Abtriebswelle.

Durch die Verschiebung des Kugelringes (14) und der Nocke (15) ändert sich die Axiallage der beweglichen Laufbahn (9) und die Radiallage der Planetenräder. Auf diese Weise ändern sich den Rollendurchmesser und die Winkelgeschwindigkeit der Abtriebswelle.

Verschiebt sich der Kontaktpunkt zwischen den Planetenrädern (7) und der äußeren Laufbahn (9) gegen das Zentrum der Planetenräder, sinkt die Ausgangsdrehzahl und das Drehmoment steigt.

#### Vorsicht

Die Geschwindigkeit darf nur verstellt werden, wenn das Verstellgetriebe im Betrieb ist und nicht wenn es still steht.

Andernfalls kommt es zu einer Beschädigung des Verstellgetriebes.

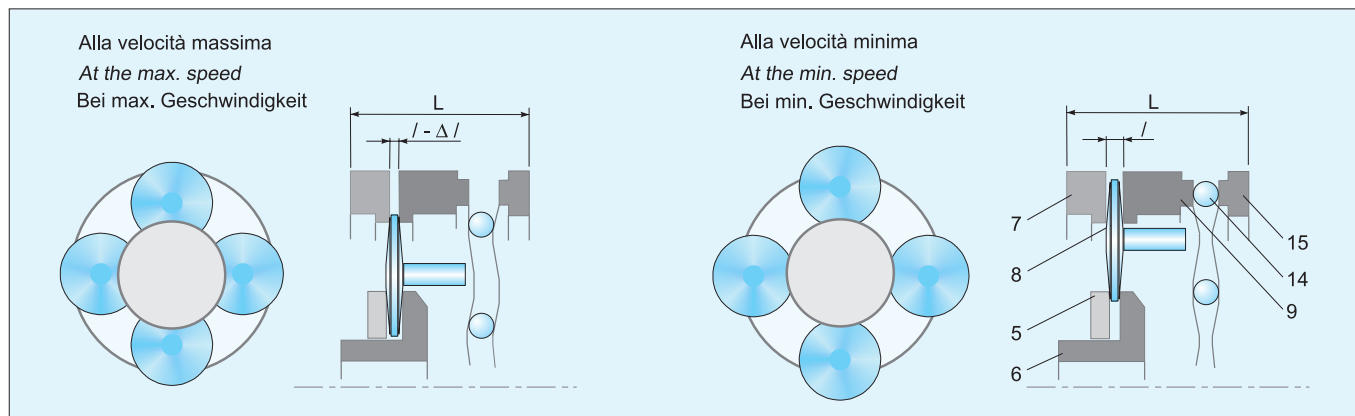

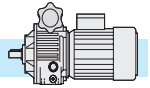

## 10.2 Variatori

La gamma dei variatori di velocità TRA-MEC si completa con la nuova serie UDL, grandezze disponibili 002, 005 e 010.

## 10.2 Variators

*The present range of Tramec speed reducers has been completed by the new UDL Series available in 3 sizes: 002, 005 and 010*

## 10.2 Verstellgetriebe

Die aktuelle Tramec Variatoren - Serie wird ergänzt durch die neue UDL Serie. Sie ist in den Größen 002, 005 und 010 erhältlich.

## 10.3 Caratteristiche

- La carcassa in alluminio, oltre ad una migliore estetica, comporta un minor peso del variatore rendendone più convenienti applicazioni e trasporti.
- Sul modulo base è possibile montare, in modo semplice e veloce, flangia uscita o piede, a seconda delle necessità. Questo riduce i volumi di stoccaggio ed i tempi di consegna.
- Il lato di entrata del variatore è chiuso, parte integrale col corpo: questo rende più facile l'installazione ed elimina totalmente la possibilità di perdite d'olio.
- È previsto, come standard, il collegamento a motori a dimensioni IEC forma B5.
- Il tappo di scarico olio è del tipo a magnete: la lubrificazione più pulita consente intervalli di manutenzione più lunghi.
- Funzionamento in bagno d'olio, silenzioso, con elevato rendimento ed esente da vibrazioni.
- Il funzionamento è possibile in entrambi i sensi di rotazione con entrata ed uscita concordi.

## 10.3 Characteristics

- *The aluminium housing benefits weight reduction for more convenient applications and transportation.*
- *The simple design allows both foot or flange mounting to standard unit, reducing stocking levels and allowing quick delivery.*
- *The closed input flange is an integral part of the variator casing for easy installation and prevents possibility of oil leaks.*
- *IEC B5 motor connections available as standard.*
- *The magnetic breather plug maintains a clean lubricant and extends maintenance intervals.*
- *The oil bath operation provides high efficiency for noiseless and vibration free running.*
- *The unit can operate in both directions, input and output shafts rotate in the same direction.*

## 10.3 Merkmale

- Dank dem Gehäuse aus Aluminium ist das Verstellgetriebe sehr leicht, was zur erleichterten Anwendung und Transport dient.
- Auf das Grundmodul können entweder Abtriebsflansch oder Fuß montiert werden. Das bringt Raumersparnis und schnellere Lieferzeit mit sich.
- Die Antriebsseite ist geschlossen und integrales Bestandteil des Gehäuses: Installation ist einfacher und Ölverluste sind ausgeschlossen.
- Standard-Anbau zu IEC B5 Motoren.
- Magnet-Ölablassschraube: die reinigere Schmierung erlaubt längere Wartungsintervalle.
- Betrieb im Ölbad ist geräuschlos, mit erhöhter Leistung und vibrationsfrei.
- Betrieb ist in beide Drehrichtungen möglich, mit Antriebs- und Abtriebswellen in derselben Richtung drehend.



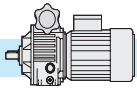

### 10.4 Designazione

### 10.4 Designation

### 10.4 Bezeichnung

Tipo Type Typ	Grandezza Size Größe	Albero uscita diam. mm Output shaft diam. mm Abtriebswelle Durchmesser mm	Flangia uscita diam. mm Output flange diam. mm Abtriebsflansch Durchmesser mm	Attacco motore IEC IEC motor adaptor IEC Motoranbau	Posizione di montaggio Mounting position Einbaulage	Potenza motore Motor power Motorleistung	N° poli Poles number Polzahl	Forma costruttiva motore Motor version Motorversion	Tensione Voltage Spannung	Frequenza Frequency Frequenz
<b>UDL</b>	<b>010</b>	<b>AU19</b>	<b>F200</b>	<b>80B5</b>	<b>B5</b>	<b>0.75 kW</b>	<b>4</b>	<b>B5</b>	<b>230/400</b>	<b>50Hz</b>
<b>UDL</b>	<b>002</b> <b>005</b> <b>010</b>	<b>AU 11</b> <b>AU 14</b> <b>AU 19</b>	<b>F 140</b> <b>F 160</b> <b>F 200</b>	<b>63 B5</b> <b>71 B5</b> <b>80 B5</b>	<b>B5</b> <b>V1</b> <b>V3</b>	<b>0.18</b> <b>0.25</b> <b>0.37</b> <b>0.55</b> <b>0.75</b>	<b>4</b>	<b>B5</b>	<b>230/400</b>	<b>50Hz</b>

### 10.5 Dati tecnici

### 10.5 Technical data

### 10.5 Technische Angaben

Tipo Type Typ	P <sub>1</sub> kW	Poli Poles Polen	Attacco motore IEC IEC motor adaptor IEC Motoranbau	n <sub>2</sub> max min <sup>-1</sup>	n <sub>2</sub> min min <sup>-1</sup>	T <sub>2</sub> min Nm	T <sub>2</sub> max Nm
<b>UDL 002</b>	<b>0.18</b>	4	63 B5	880	170	1.5	3
<b>UDL 005</b>	<b>0.25</b>	4	71 B5	1000	200	2	6
	<b>0.37</b>			1000	200	3	6
<b>UDL 010</b>	<b>0.55</b>	4	80 B5	1000	200	4.4	12
	<b>0.75</b>	4		1000	200	6	12

### 10.6 Lubrificazione

### 10.6 Lubrification

### 10.6 Schmierung

I variatori vengono forniti completi di lubrificante. Dopo il piazzamento del variatore assicurarsi che il livello del lubrificante sia visibile dall'apposita spia di livello effettuando eventuali rabbocchi se necessario, con un analogo lubrificante scelto fra quelli raccomandati in tabella.

*The variators are supplied complete with lubricant. After the mounting pls make sure the oil can be seen through the oil level plug this to allow the filling up if necessary. Oil has to be selected among the recommended ones.*

Die Verstellgetriebe werden mit Schmiermittel geliefert. Nach Einbau des Verstellgetriebes ist der Ölstand durch das Schauglas zu prüfen. Wenn nötig, füllen Sie mit einem der empfohlenen Öle auf (siehe Tabelle).

Tipi di lubrificanti raccomandati / Recommended lubricants / Empfohlene Öle	
Dexron fluid II	<b>IP</b>
A.T.F. Dexron fluid DIII	<b>SHELL</b>
A.T.F. 200 RED	<b>MOBIL</b>
A.T.F. Dexron	<b>FINA</b>
BP Autran DX	<b>BP</b>
A.T.F. Dexron	<b>ESSO</b>
A.T.F. Dexron	<b>CHEVRON</b>
A.T.F. Dexron	<b>AGIP</b>

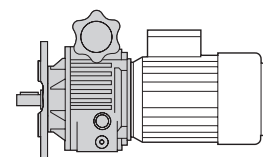

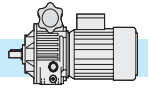

### 10.7 Posizioni di montaggio

### 10.7 Mounting positions

### 10.7 Einbaulagen

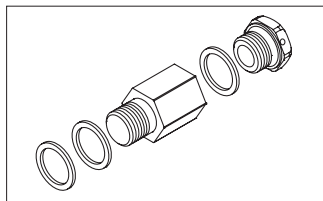
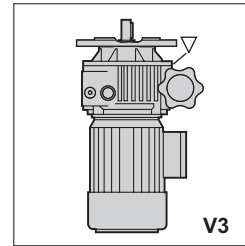
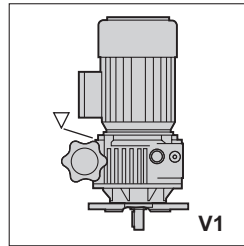
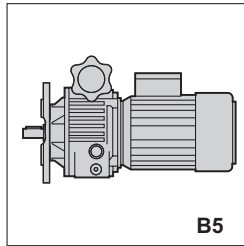

- ▽ Kit Tappo di sfiato  
solo per posizione di montaggio V1, V3
- ▽ Kit breather plug  
only for mounting positions V1, V3
- ▽ Kit Entlüftungsschraube  
Nur für die Einbaulagen V1, V3

### 10.8 Dimensioni

### 10.8 Dimensions

### 10.8 Abmessungen

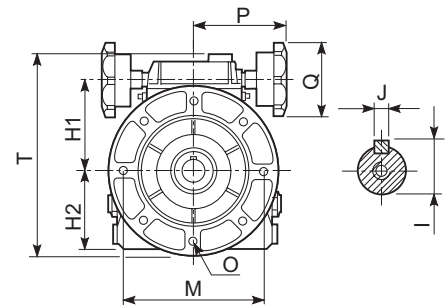
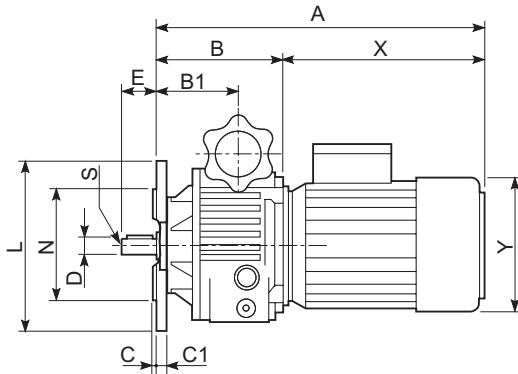

Tipo Type Typ	A	B	B1	C	C1	D	H1	H2	I	J	L	M	N	O	P	Q	S	T	X	Y	Kg
<b>UDL 002</b>	318.5	111.5	64	3.5	6.5	11	78	70	12.5	4	140	115	95	9	113	70	M5	183	207	130	3.3
<b>UDL 005</b>	333	108	71.5	3.5	8.5	14	91	80	16	5	160	130	110	9	113	70	M5	205	225	145	4.6
<b>UDL 010</b>	398.5	143.5	87.5	3.5	10.5	19	107	100	21.5	6	200	165	130	11	120	85	M6	242	255	175	7.9

I valori A, X e Y dipendono dal motore utilizzato *The values A, X and Y depend on the electric motor used.*

Die Werte A, X und Y auf den Elektromotor abhängen

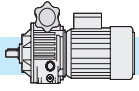

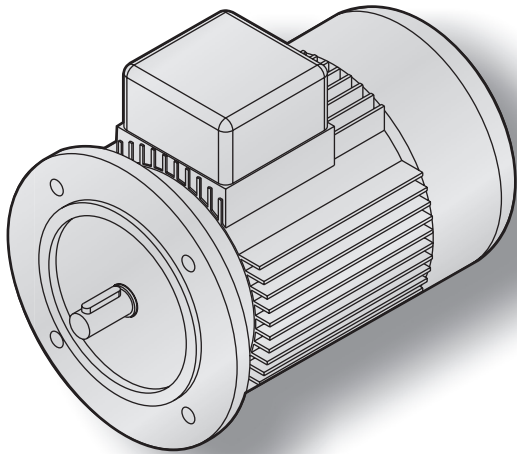

**B5**

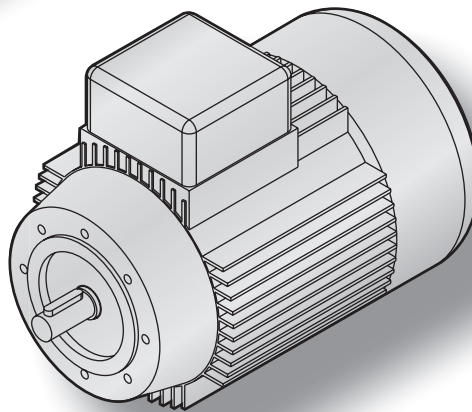

**B14**

## B5

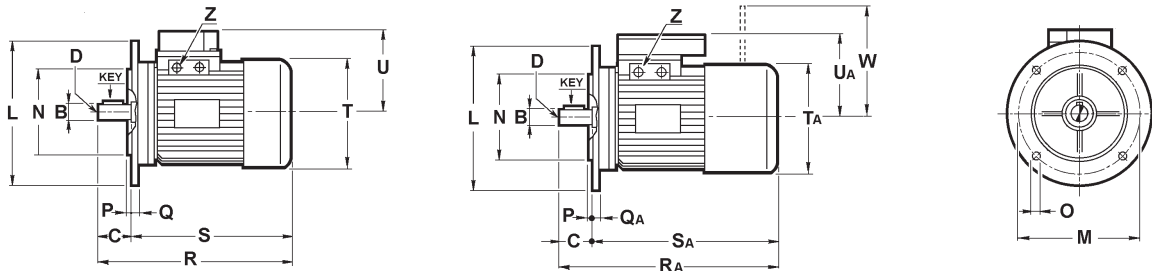

Motori elettrici <sup>(1)</sup>  
Electric motors  
Elektromotoren

Motori elettrici autofrenanti <sup>(2)</sup>  
Electric brake motors  
Elektro-Bremsmotoren

	4 poles	kW	kg. (1)	kg. (2)	B	C	D	L	M	N	O	P	Q	QA	R	RA	S	SA	T	TA	U	UA	W	Z	KEY	
56	A	0.06	2.5	4	9	20	M4	120	100	80	7	3	8	8	188	220	168	200	110	110	108	108	90	PG11	3x3x15	
	B	0.09	2.6	5																				PG11	3x3x15	
	C	0.11	3.2	5																				PG11	3x3x15	
63	A	0.13	3.7	5	11	23	M4	140	115	95	9	3	9	9	208	257	185	234	123	123	110	110	98	PG11	4x4x15	
	B	0.18	4.3	7																				PG11		
	C	0.22	4.3	7																				PG11		
71	A	0.25	5.8	8	14	30	M5	160	130	110	9	3.5	9	9	245	297	215	267	140	140	121	121	98	PG11	5x5x20	
	B	0.37	6.2	8																				PG11		
	C	0.55	7.4	9																				PG11		
80	A	0.55	8.5	11	19	40	M6	200	165	130	11	3.5	10	10	278	336	238	296	159	159	138	138	111	PG16	6x6x30	
	B	0.75	9.8	13																				PG16		
	C	0.9	10.5	13.5																				PG16		
90	S	1.1	12	17	24	50	M8	200	165	130	11	3.5	10	10	305	369	255	319	176	176	149	149	129	PG16	8x7x35	
	L	1.5	13.5	18											330	394	280	344						PG16		
	LB	1.8	15.5	20											PG16											
100	A	2.2	19	25.5	28	60	M10	250	215	180	14	4	14	14	369	434	309	374	195	195	160	160	139	PG16	8x7x45	
	B	3	21	28																				PG16		
	BL	4	23	30																				PG16		
112	A	4	29	38	28	60	M10	250	215	180	14	4	14	14	388	467	328	407	219	219	172	172	161	PG16	8x7x45	
	BL	5.5	35	44																				PG16		
	S	5.5	43	56																				448		570
M	7.5	52	66	485	600	405	520	320	330	245	245	360	370	275	275	1" G										
ML	9.2	54	68	610	805	500	695	654	860	544	750	697	880	587	770	735	920	625	810	400	410	300	300	1"1/4 G	16x10x90	
160	M	11	96		42	110	M16	350	300	250	18	5	15	15	610	805	500	695	320	330	245	245			1" G	12x8x90
	L	15	109	654											860	544	750									
180	M	18.5	121		48	110	M16	350	300	250	19	5	15	15	697	880	587	770	360	370	275	275			1" G	14x9x90
	L	22	151	735											920	625	810									
200	L	30	193		55	110	M16	400	350	300	19	5	15	15	800	1060	690	950	400	410	300	300			1"1/4 G	16x10x90
225	S	37	313		60	140	M20	450	400	350	18	5	16		830		690		450		330				1"1/4 G	18x11x120
	M	45	355																							

Le dimensioni dei motori elettrici sono puramente indicative.

The dimensions of the electric motors are approximate values.

Die Abmessungen der Elektromotoren sind Näherungswerte.

## B14

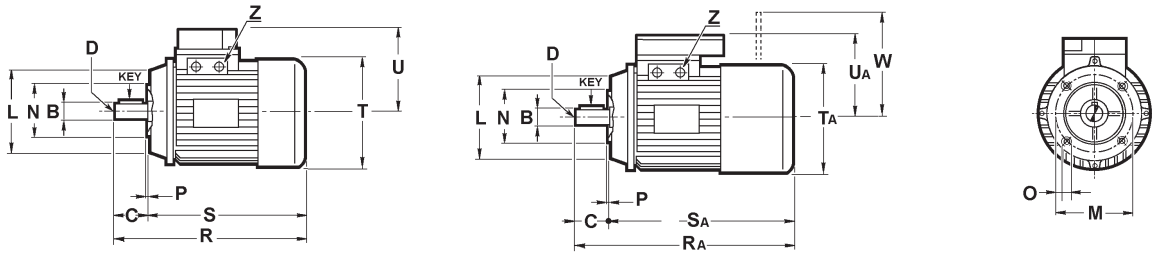

Motori elettrici <sup>(1)</sup>  
Electric motors  
Elektromotoren

Motori elettrici autofrenanti <sup>(2)</sup>  
Electric brake motors  
Elektro-Bremsmotoren

		4 poles		B	C	D	L	M	N	O	P	R	RA	S	SA	T	TA	U	UA	W	Z	KEY	
		kW	kg. (1)																				kg. (2)
56	A	0.06	2.5	4	9	20	M4	80	65	50	M5	2.5	188	220	168	200	110	110	108	108	90	PG11	3x3x15
	B	0.09	2.6	5																		PG11	3x3x15
	C	0.11	3.2	5																		PG11	3x3x15
63	A	0.13	3.7	5	11	23	M4	90	75	60	M5	2.5	208	257	185	234	123	123	110	110	98	PG11	4x4x15
	B	0.18	4.3	7																		PG11	
	C	0.22	4.3	7																		PG11	
71	A	0.25	5.8	8	14	30	M5	105	85	70	M6	2.5	245	297	215	267	140	140	121	121	98	PG11	5x5x20
	B	0.37	6.2	8																		PG11	
	C	0.55	7.4	9																		PG11	
80	A	0.55	8.5	11	19	40	M6	120	100	80	M6	3	278	336	238	296	158	159	138	138	111	PG16	6x6x30
	B	0.75	9.8	13																		PG16	
	C	0.9	10.5	13.5																		PG16	
90	S	1.1	12	17	24	50	M8	140	115	95	M8	3	305	369	255	319	176	176	149	149	129	PG16	8x7x35
	L	1.5	13.5	18									330	394	280	344			160				
	LB	1.8	15.5	20																			
100	A	2.2	19	25.5	28	60	M10	160	130	110	M8	3.5	369	434	309	374	195	195	173	160	139	PG16	8x7x45
	B	3	21	28																			
	BL	4	23	30																			
112	A	4	29	38	28	60	M10	160	130	110	M8	3.5	388	467	328	407	219	219	192	172	161	PG16	8x7x45
	BL	5.5	35	44																		PG16	
132	S	5.5	43	56	38	80	M12	200	165	130	M10	4	448	570	368	490	258	258	192	192	186	PG21	10x8x60
	M	7.5	52	66									485	600	405	520							
	ML	9.2	54	68																			

Le dimensioni dei motori elettrici sono puramente indicative.

The dimensions of the electric motors are approximate values.

Die Abmessungen der Elektromotoren sind Näherungswerte.



## 12.0

### CONDIZIONI GENERALI DI VENDITA

### TERMS AND CONDITIONS OF SALE

12.1	Scopo	<i>Purpose</i>	158
12.1.1	Modifiche alle condizioni generali di vendita	<i>Modification of the conditions of sale</i>	158
12.2	Definizioni generali	<i>General definitions</i>	158
12.3	Riferimenti	<i>References</i>	158
12.4	Offerte e ordinazioni	<i>Offers and orders</i>	158
12.4.1	Offerte	<i>Offers</i>	158
12.4.2	Ordini	<i>Orders</i>	159
12.4.3	Conferma d'ordine	<i>Order confirmation</i>	159
12.5	Prezzo dei prodotti	<i>Price of the products</i>	159
12.6	Spedizione e trasporto	<i>Shipping and transport</i>	160
12.7	Termini di consegna	<i>Terms of delivery</i>	160
12.8	Pagamenti	<i>Payments</i>	160
12.8.1	Reclami e/o contestazioni	<i>Claims and / or disputes</i>	160
12.8.2	Non conformità	<i>Non-compliance</i>	161
12.8.3	Restituzione del materiale	<i>Return of material</i>	161
12.8.4	Garanzia dei prodotti	<i>Product warranty</i>	161
12.9	Marchi e diritti di proprietà intellettuale	<i>Trademarks and intellectual property rights</i>	161
12.10	Controversie e risoluzione contrattuale	<i>Disputes and contract termination</i>	162
12.10.1	Clausola risolutiva art. 1455 C.C.	<i>Termination art. 1455 C.C. (Italian Civil Code)</i>	162
12.10.2	Clausola risolutiva art. 1461 C.C.	<i>Termination art. 1461 C.C. (Italian Civil Code)</i>	162



## 12.1 Scopo

Le presenti "Condizioni Generali di Vendita" (di seguito denominate "Condizioni di Vendita"), si applicano e regolano tutte le forniture di prodotti con marchio "TRAMEC" e/o commercializzate dalla stessa, e annullano qualsiasi clausola o termine pattuito dal Cliente, sia nella singola vendita che in documentazioni di provenienza dello stesso, che non sia state accettate da un preventivo consenso scritto da parte di "TRAMEC Srl".

### 12.1.1 Modifiche alle condizioni di vendita

"TRAMEC Srl" si riserva il diritto di modificare, aggiungere, cancellare qualsiasi punto delle presenti Condizioni di Vendita, che si riterranno applicate a tutti gli ordini successivi alla data di notifica al Cliente delle nuove Condizioni di Vendita.

## 12.2 Definizioni generali

Per una maggiore chiarezza nella lettura delle presenti Condizioni di Vendita, si definiscono i seguenti termini:

- "TRAMEC" : TRAMEC Srl, Via Bizzarri,6 – 40012 Caldera di Reno (BO) - ITALY
- "Prodotti": Tutti i beni prodotti, assemblati, commercializzati e/o venduti da TRAMEC Srl
- "Cliente" : Tutte le società legalmente costituite e/o entità giuridiche che acquistano beni, prodotti o servizi da TRAMEC Srl
- "Ordine" : Ogni proposta di acquisto di beni, prodotti o servizi inoltrata da un cliente a TRAMEC Srl e confermata per accettazione con "Conferma d'ordine" dalla stessa.
- "Marchi" : Tutti i marchi di proprietà di TRAMEC Srl di cui è proprietaria e/o licenziataria
- "Brevetti e Proprietà Intellettuale" : Qualsiasi diritto legato alla protezione del proprio Know-How, coperto da brevetti italiani e internazionali, per invenzioni, marchi, modelli, disegni e prodotti di cui TRAMEC Srl ne detiene ed è proprietaria dei diritti, siano essi registrati, che in fase di registrazione compresi qualsiasi altra forma prevista dalla leggi internazionali.

## 12.3 Riferimenti

Il presente documento è parte integrante del "LISTINO PREZZI TRAMEC", di cui copia è pubblicata sul sito aziendale [www.tramec.it](http://www.tramec.it)

## 12.4 Offerte e ordinazioni

### 12.4.1 Offerte

Su richiesta del Cliente, TRAMEC direttamente o attraverso la propria rete vendita, formulerà una proposta di acquisto per i propri prodotti indicati dal Cliente, formalizzandola per iscritto. L'offerta di vendita/proposta di acquisto non è da ritenersi impegnativa da parte del Cliente, e avrà validità 30(trenta) giorni. Allo scadere di tale termine, TRAMEC si riterrà svincolata da impegni e su richiesta del cliente riformulerà una nuova offerta/proposta. Data la natura riservata del contenuto dell'offerta/proposta ricevuta il Cliente, si impegna a non divulgarne il contenuto.

## 12.1 Purpose

*The present "General Conditions of Sale" (hereinafter referred to as "Conditions of Sale"), shall apply and shall govern all supplies of "TRAMEC" products with "TRAMEC" label and / or directly commercialized by "TRAMEC", and cancel any clause or term agreed upon by the Customer which have not been accepted by prior consent in writing by "TRAMEC Srl".*

### 12.1.1 Modification of the conditions of sale

*"TRAMEC SRL" reserves the right to modify, add, delete any part of these "Conditions of Sale", which will be deemed to apply to all orders received after the date of Customer's notification.*

## 12.2 General definitions

*For a better understanding of these Conditions of Sale, we define the following terms:*

- "TRAMEC" : TRAMEC Srl, Via Bizzarri,6 – 40012 Caldera di Reno (BO) - ITALY
- "Products": *All goods manufactured, assembled, commercialized and / or sold by TRAMEC Srl.*
- "Customers" : *All companies legally established and / or legal entities buying goods, products or services from TRAMEC SRL*
- "Orders" : *Each offer to purchase goods, products or services sent by the Customer to TRAMEC Srl and confirmed for acceptance with an "order confirmation" directly from TRAMEC Srl*
- "Trademarks" : *All trademarks owned or of which TRAMEC Srl is licensee.*
- "Patents and Intellectual Property" : *all rights related to the protection of their own Know - How, covered with Italian and international patents for inventions, trademarks, models, designs and products for which TRAMEC SRL holds and owns the rights, whether registered or under registration, including any other form prescribed by the International laws.*

## 12.3 References

*This document is an integral part of the "PRICE LIST of TRAMEC", a copy of which is posted on the company website [www.tramec.it](http://www.tramec.it)*

## 12.4 Offers and orders

### 12.4.1 Offers

*On customer request, TRAMEC directly or through its own sales network, will submit a written proposal for the products required by the Customer. The offer shall not be binding for the Customer and will have a 30 (thirty) days validity. After this period the offer is void and upon Customer request TRAMEC will submit a new proposal. TRAMEC written offers are intended for the receipt and viewing of the Customer, and disclosure of the offer with competitors could render the offer null and void.*

### 12.4.2 Ordini

Tutti gli ordini di acquisto dei prodotti TRAMEC, devono essere formalizzati per iscritto dal Cliente su propria carta intestata ed inviati tramite mail, fax o lettera direttamente ai riferimenti indicati nell'offerta/proposta ricevuta, avendo cura di aver indicato:

- Riferimento a n. offerta,
- codice prodotto,
- descrizione prodotto,
- quantità richiesta,
- prezzi e termini di consegna.

TRAMEC ha previsto la possibilità di accettare anche ordini a carattere di "URGENZA" **previ accordi telefonici con il commerciale TRAMEC di riferimento**, che devono essere formalizzati per iscritto dal Cliente, e che prevedono una consegna entro 5 (cinque) oppure 6-9 (da sei a nove) gg lavorativi dalla data di accettazione dell'ordine stesso. A tali ordini verrà applicato una maggiorazione del 15%(quindicipercento) e del 7% (settepercento) rispettivamente, calcolata sul totale lordo EX WORKS dell'ordine, in aggiunta agli importi netti totali.

#### ATTENZIONE

**Tutti gli ordini a carattere d'urgenza, una volta accettati e confermati da TRAMEC, non saranno più modificabili né cancellabili.**

### 12.4.3 Conferma d'ordine

La vendita si riterrà conclusa con l'invio della Conferma d'Ordine che TRAMEC inoltrerà al Cliente. Tale Conferma d'Ordine sarà inoltrata al cliente tramite mail o su richiesta tramite fax direttamente ai riferimenti indicati dal Cliente. La Conferma d'Ordine sarà conforme, all'ordine di acquisto del Cliente ricevuto da TRAMEC, sia nei termini che nelle condizioni indicate e concordate. Trascorsi 2 (due) giorni lavorativi dall'invio della Conferma d'Ordine, TRAMEC riterrà confermato l'ordine da parte

del Cliente ed ogni inesattezza eventualmente contenuta e non contestata in forma scritta da parte del Cliente e confermata sempre in forma scritta da TRAMEC (con nuova Conferma d'Ordine revisionata), evidenziata alla consegna dei prodotti al Cliente non sarà più contestabile o annullabile.

### 12.5 Prezzo dei prodotti

Tutti i prezzi dei prodotti indicati negli ordini di vendita, e nelle relative offerte, fanno riferimento al listino prezzi TRAMEC, in vigore al momento del loro inoltro al Cliente. Qualora non fosse presente il prodotto in ordine nel listino prezzi TRAMEC, avrà valore quanto concordato e confermato per iscritto nell'ordine stesso.

Eccetto quanto concordato per iscritto tra le parti, i prezzi indicati nell'ordine di vendita TRAMEC sono calcolati franco fabbrica, al netto dell'IVA e degli sconti. Tali prezzi inoltre non includono eventuali costi di imballaggio, spedizione e trasporto dai locali di TRAMEC ai locali del cliente, che saranno sostenuti separatamente dal Cliente.

TRAMEC manterrà la proprietà dei Prodotti venduti al Cliente fino alla completa corresponsione del prezzo degli stessi. La presente clausola di riserva di proprietà, obbliga il Cliente a compiere tutti gli adempimenti previsti per legge, ove previsto, per rendere valida ed eseguibile nei confronti di tutti i terzi tale vincolo.

TRAMEC si riserva il diritto di modificare unilateralmente e senza preavviso, con effetto immediato i prezzi riportati nel proprio listino, nei casi in cui l'adeguamento sia dovuto a cambiamenti impreveduti di condizioni di mercato delle materie prime o dei tassi di cambio. Ogni modifica verrà comunque comunicata al Cliente ed applicata al successivo ordine ricevuto.

### 12.4.2 Orders

*All purchase orders of TRAMEC products must be formalized in writing by the customer, on his own letterhead and sent via mail, fax or letter directly to the references mentioned in the offer, making sure to add :*

- Offer reference number ,
- Product Code,
- Product Description,
- Required Quantity,
- Prices and Terms of Delivery.

*An "URGENT" production option may be agreed case by case with the sales department of TRAMEC. To accept the urgent production option , Customer must state in writing, requesting URGENT option, and consider standard shipment of urgent orders to be either 5 (five) or 6-9 (from six to nine) working days from the date of TRAMEC's acceptance of order, depending on availability at order time. Such urgent orders will be charged an additional 15% (fifteen percent) or 7% (seven percent) respectively, calculated on the total EX WORKS value of the order.*

#### ATTENTION!!!!

***Urgent orders, once acknowledged by TRAMEC, are non-cancelable and may not be modified.***

### 12.4.3 Order confirmation

*TRAMEC will acknowledge the Customers Order via e mail or on request by fax to the address specified by the Customer. All Orders to be performed are subject to the Terms and Conditions Agreed to between the parties.*

*The Customer will have two (2) days to review the acknowledgment for errors or inaccuracies to notify TRAMEC for correction, after these two (2) days the Order will be considered acknowledged by the Customer and can no longer be contested or canceled.*

### 12.5 Price of the products

*All prices listed on the sales orders, and on offers, refer to the Price List of "TRAMEC" valid at time of their transmission to the Customer.*

*If the product is not mentioned on the Price List of "TRAMEC", its value will be the one agreed to between the parties in writing.*

*Unless differently agreed, the prices indicated on the sales order of TRAMEC will be calculated on ex-works basis, VAT and Discounts excluded.*

*These prices do not include any costs for packaging, shipping and transport from TRAMEC warehouse to the Customer premises, which will be paid separately by the Customer.*

*TRAMEC will retain the ownership of the Products sold to the customer until their complete payment. Because of this saving clause of ownership, the Customer is due to carry out all formalities required by law, and if necessary, to make such a constraint valid and enforceable against all third.*

*TRAMEC reserves the right to modify the prices of the price list, unilaterally and without notice, with immediate effect , if the adjustment is due to unexpected changes in market conditions, in raw materials or in exchange rates. Each modification will however be noted and indicated on the Order Acknowledgement and will apply to the next order.*

## 12.6 Spedizione e trasporto

La spedizione viene effettuata tramite vettori nazionali ed internazionali, indicati dal Cliente o in mancanza di indicazioni scelti in autonomia da TRAMEC. La scelta del vettore viene effettuata sulla base di valutazione di convenienza e di garanzia del trasporto che il vettore stesso assicura/certifica. Tutto il materiale viaggia a spese e rischio del Cliente stesso, e si intende accettato dal Cliente all'atto di inizio del trasporto da parte del vettore. Eventuali danni occorsi al materiale durante il trasporto, non sono coperti da garanzia TRAMEC.

Come indicato al punto 12.5 PREZZO DEI PRODOTTI, la merce viaggia sempre FRANCO FABBRICA.

## 12.7 Termini di consegna

I termini di consegna indicati nella Conferma d'Ordine, hanno carattere puramente indicativo e sono da ritenersi fissati salvi imprevisti ascrivibili a circostanze di forza maggiore e che siano fuori dal proprio controllo. A titolo esemplificativo e senza pretesa di esaustività si elenca quanto segue:

- a) Ritardi da parte del cliente a fornire dati tecnici o amministrativi necessari alla spedizione dei prodotti
- b) Difficoltà da parte di TRAMEC nell'acquisizione di materie prime necessarie alla produzione dei prodotti
- c) Scioperi parziali o totali, calamità naturali, difficoltà nel trasporto dei materiali, etc. e tutte le altre cause di forza maggiore
- d) Ritardi dovuti a terzi o allo spedizioniere

Il verificarsi di alcuni degli eventi elencati o di altra natura non elencati, non darà diritto al Cliente di esigere indennizzi di sorta o richiesta di risarcimento danni.

## 12.8 Pagamenti

TRAMEC a propria discrezione emetterà fattura, salvo accordi scritti tra le parti, all'atto della spedizione dei prodotti o in anticipo all'atto dell'accettazione dell'ordine del Cliente. Tutti i pagamenti sono previsti in EURO, eccetto per accordi commerciali che prevedano altra valuta. I pagamenti devono essere effettuati entro i termini stabiliti indicati nella Conferma d'Ordine, anche in presenza di reclami o contestazioni.

Ogni ritardo o mancato pagamento rispetto ai termini stabiliti darà diritto a TRAMEC di sospendere qualsiasi consegna di prodotti e/o ordine in corso e richiedere al Cliente il pagamento degli interessi bancari così come previsto dalle leggi vigenti nella misura del tasso stabilito da BCE + 7% (Settepercento).

Ogni reclamo e/o contestazione non potrà comunque in nessun modo giustificare la sospensione o il ritardato pagamento.

### 12.8.1 Reclami e/o contestazioni

Ogni tipologia di reclamo o contestazione dovrà essere formalizzato/a a TRAMEC in forma scritta direttamente all'indirizzo email [customer.care@tramec.it](mailto:customer.care@tramec.it) o attraverso la sezione "Customer Care" presente sul proprio sito [www.tramec.it](http://www.tramec.it). Eventuali reclami riferiti a vizi o difetti dei prodotti ricevuti dovranno essere segnalati a TRAMEC, sempre in forma scritta, entro 10 (dieci) gg dalla data di consegna.

Nel caso che tali vizi o difetti si evidenziassero, per la loro natura, successivamente alla data di consegna, essi dovranno essere segnalati, sempre in forma scritta, a TRAMEC immediatamente entro e non oltre 5 (cinque) gg dalla data di rilevazione, e comunque saranno ritenuti tali entro e non oltre l'anno di garanzia previsto per i prodotti TRAMEC.

Le spese di trasporto sono a carico del Cliente salvo diverso accordo tra le parti.

## 12.6 Shipping and transport

*Shipments will be handled by national and international carriers specified by the Customer, if specific instructions are not included they will be at TRAMEC's discretion. Where shipment is made at TRAMEC's discretion, carrier choice will be made based on convenience and delivery terms assured by the carriers. Goods are sold to Customer and considered EX-WORKS (see 12.5.PRICE OF THE PRODUCTS), all transportation expense, loss, damages, or delays to be the risk and responsibility of the Customer and their carrier, and not subject to TRAMEC warranty written or implied.*

## 12.7 Terms of delivery

*Delivery terms mentioned in "TRAMEC" Order Confirmation are considered agreed upon and to be honored bearing unexpected events outside "TRAMEC" control, in example:*

- a) The Customers delay of technical or administrative information necessary for the timely dispatch of the products.*
- b) Difficulties in the acquisition of raw materials required to manufacture TRAMEC products.*
- c) Total or partial labor strikes, natural disasters, transportation difficulties or other circumstances beyond TRAMEC control.*
- d) Delays due to third parties or to be inbound shipping company*

*The occurrence of some of the events listed or other not listed, do not entitle the customer to claim any compensation or claim for damages.*

## 12.8 Payments

*Unless stated in writing and agreed upon, "TRAMEC" will invoice the Customer on Confirmation of Order for Customers with Prepaid Terms, or at time of shipment for the Customers with NET trade credit terms. Payments are to be made in EURO, except where specific commercial agreements are made in alternative currencies. Payments must be made within the stated NET terms offered at time of Order Confirmation, regardless of outside claims or conflicts.*

*Delay or missing payments outside of the agreed terms will afford TRAMEC the right to suspend any delivery of products, services, and any pending orders, as well as require the Customer to pay interest on past due invoices, as provided by law, to the extent determined by the ECB rate + 7% (seven percent)*

*NO claim or dispute can justify the suspension, delay, or non-payment of invoices due.*

### 12.8.1 Claims and / or disputes

*Each complaint or claim must be transmitted in writing to "TRAMEC", directly to the e mail address [customer.care@tramec.it](mailto:customer.care@tramec.it) or through the website [www.tramec.it](http://www.tramec.it), "Customer Care" section.*

*Any claim relating to defect must be reported in writing to "TRAMEC" within 10 (ten) days of the receipt of the product.*

*If a defect is noticed or occurs after the delivery date, it must be reported in writing to TRAMEC within 5 (five) days of the date the defect was detected, and always within the 1 (one) year warranty provided for TRAMEC products.*

*Transportation costs are borne by the Customer unless otherwise agreed to by TRAMEC and the Customer.*

### 12.8.2 Non conformità

Eventuali non corrispondenze in tipologia del prodotto e/o quantità, rispetto a quanto indicato in Conferma d'Ordine, dovrà essere prontamente segnalata in forma scritta a TRAMEC o al proprio agente di riferimento entro e non oltre 5(cinque) gg dalla data di consegna del materiale. Dopo tale scadenza i prodotti consegnati si riterranno conformi all'ordine del Cliente e non potranno essere più contestati a TRAMEC. Le spese di trasporto sono a carico del Cliente salvo diverso accordo tra le parti.

### 12.8.3 Restituzione del materiale

Il materiale non può essere restituito a TRAMEC, senza preventiva autorizzazione scritta da parte della stessa. Eventuali materiali ricevuti senza che il Cliente abbia effettuato una segnalazione scritta così come previsto ai punti 12.8.1 e 12.8.2, ed autorizzata da TRAMEC, verranno respinti al mittente, con addebito delle spese di trasporto salvo diverso accordo tra le parti.

### 12.8.4 Garanzia dei prodotti

TRAMEC garantisce i propri prodotti, così come previsto dalle leggi vigenti, per un periodo di 1 (uno) anno dalla data di fatturazione degli stessi. La garanzia opererà su tutti i prodotti TRAMEC, ove saranno rilevabili difetti di costruzione, montaggio o progettazione e comporterà per TRAMEC l'onere della sostituzione o riparazione delle parti difettose senza nessun altro aggravio e/o addebiti per danni diretti e/o indiretti di qualsiasi natura.

La garanzia decade nel caso siano state eseguite riparazioni, modifiche o manomissioni senza autorizzazione scritta da parte di TRAMEC e nel caso di mancanza della targhetta originale di fabbrica, presente su tutti i prodotti TRAMEC.

Un uso negligente o improprio e inosservanza delle prescrizioni sull'uso, manutenzione e conservazione dei prodotti, comporterà la decadenza immediata della garanzia. Il prodotto, coperto da garanzia, dovrà essere restituito a TRAMEC, così come indicato al punto 12.8.3, con spese di trasporto a carico del Cliente salvo diverso accordo tra le parti. La proprietà del prodotto o componente sostituito in garanzia, ove risultasse difettoso, sarà trasferita a TRAMEC dal Cliente.

Ogni diritto di garanzia non sarà applicabile, su quei prodotti a cui ancora non siano stati completamente corrisposti, alle condizioni e termini pattuiti, i relativi importi dovuti così come da fattura di riferimento. TRAMEC inoltre non garantisce nessuna garanzia circa alle conformità dei prodotti a norme e regolamenti di Paesi o Stati che non rientrano e appartengano alla Comunità Europea.

### 12.9 Marchi e diritti di proprietà intellettuale

TRAMEC è l'unica titolare dei propri Marchi, ed il Cliente si asterrà dall'utilizzo degli stessi senza preventiva autorizzazione, o registrare Marchi simili e/o confondibili con i medesimi. Ogni loro utilizzo comunque dovrà essere autorizzato in forma scritta da TRAMEC sia nelle modalità che nella forma, secondo indicazioni concordate con il titolare dei Marchi.

Tutti i diritti di Proprietà Intellettuale sono di totale ed esclusiva proprietà di TRAMEC e la loro comunicazione o utilizzo nell'ambito delle presenti "Condizioni Generali di Vendita" non produce nessun diritto o pretesa in capo al Cliente, che si obbliga a non compiere atti o richieste a contestarne la Titolarità e Proprietà.

### 12.8.2 Non-compliance

*Any non-compliance with either product or its quantity found to be different from what is stated on Order Confirmation, must be reported in writing to TRAMEC or its Agent, no later than 5 (five) days from the delivery date of the material.*

*With no notification made after this time, the products will be considered complying with the order acknowledged to the Customer and shall no longer be contested to TRAMEC. Transportation costs are borne by the Customer unless otherwise agreed to by TRAMEC and the Customer.*

### 12.8.3 Return of material

*No goods or materials can be returned without "TRAMEC" prior written authorization. Materials received without authorization and written report from the Customer, as required in point 12.8.1 & 12.8.2, and fully authorized by "TRAMEC", will be returned to the sender at the senders expense for all transportation and customs fees, unless otherwise agreed to between the parties in writing.*

### 12.8.4 Product warranty

*"TRAMEC" guarantees its products, as provided by law, for a period of 1 (one) year from the date of invoice. This guarantee will be valid for all "TRAMEC" products, where construction, installation or design defects will be detected and will lead to "TRAMEC" the burden of replacement or repair of defective parts at its discretion without any other burden or responsibility or charges for any direct and / or indirect damages or expense.*

*"TRAMEC" warranty is void if repairs, changes or alterations are carried out on the product without the written consent of "TRAMEC", and only valid with the original nameplate which is found on all "TRAMEC" products.*

*The negligent or improper use as well as failure to observe regulations governing the utilization, maintenance and storage of products, will result in the immediate loss of this guarantee. The product, covered by the warranty, will have to be returned to "TRAMEC" free of charge, as indicated in point 12.8.3, with all transportation costs borne by the Customer unless otherwise agreed between the parties in writing. The product or component replaced under warranty, if it is defective, will belong to "TRAMEC".*

*The warranty will not be valid for products that are not paid in full, according to the conditions and terms agreed, and for the amounts due per relevant invoice.*

*"TRAMEC" provides no guarantee as for the conformity of their products with the standards and regulations of Countries or States not belonging to the European Community.*

### 12.9 Trademarks and intellectual property rights

*TRAMEC is the sole owner of its brands, and the Customer will refrain from the use of them without prior authorization, or register similar ones and/or brands that are easily confused with TRAMEC's brands. Every use of TRAMEC brands requires the authorization in writing by TRAMEC, both in terms and form, according to instructions agreed with the owner of these trademarks.*

*All Intellectual Property Rights are the complete and exclusive property of TRAMEC and their communication or use under these "Terms of Sale" does not product any right or claim to the Customer, which is obliged to refrain from acts or request to question the Possessory title and Property.*

## **12.10 Controversie e risoluzione contrattuale**

Tutte le controversie derivanti da o connesse alle presenti Condizioni di Vendita e/o ad ogni vendita, sono assoggettabili alla esclusiva giurisdizione del Foro competente di Bologna (ITALIA).

TRAMEC Srl è legalmente domiciliata presso la sua sede principale di Via Bizzarri,6 – 40012 Calderara di Reno(BO) – ITALY.

### **12.10.1 Clausola risolutiva art. 1455 C.C.**

TRAMEC avrà facoltà di risolvere, ai sensi e per gli effetti dell'art. 1455 del Codice Civile Italiano, in qualsiasi momento con comunicazione scritta al Cliente, la singola vendita nel caso di inadempimento delle obbligazioni così come previsto ai punti 12.5 (Prezzo dei Prodotti), 12.8 (Pagamenti), 12.9 (Marchi e Diritti di Proprietà Intellettuale).

### **12.10.2 Clausola risolutiva art. 1461 C.C.**

TRAMEC avrà diritto di sospendere, ai sensi e per gli effetti dell'art. 1461 del Codice Civile Italiano, in qualsiasi momento con comunicazione scritta al Cliente, tutte le obbligazioni in corso derivanti dalla vendita dei prodotti, nel caso in cui le condizioni patrimoniali del Cliente divenissero e/o risultassero tali da porre in serio dubbio la naturale acquisizione della contropartita prevista.

TRAMEC potrà valutare eventuali garanzie accessorie proposte dal Cliente, come assicurazione sulle obbligazioni in essere.

## **12.10 Disputes and contract termination**

*All disputes due or related to these "Terms of Sale" and / or any sale, are subject to the exclusive jurisdiction of the Competent Court of Bologna (ITALY).*

*TRAMEC SRL is legally domiciled at its headquarters in Via Bizzarri, 6-40012 Calderara di Reno (BO) - ITALY.*

### **12.10.1 Termination art. 1455 C.C. (Italian Civil Code)**

*"TRAMEC" may terminate, pursuant to art. 1455 of the Italian Civil Code, at any time by written notice to the Customer, the single sale in the event of breach of the obligations as set out in paragraphs 12.5 (Product Price), 12.8 (Payments), 12.9 (Trademarks and Intellectual Property Rights) .*

### **12.10.2 Termination art. 1461 C.C. (Italian Civil Code)**

*"TRAMEC" will be entitled to suspend, pursuant to art. 1461 of the Italian Civil Code, at any time by written notice to the Customer, all current obligations arising from the sale of the products, in the event that the financial conditions of the Customer would become and/or result to call into serious doubt the natural acquisition of expected offset.*

*"TRAMEC" may consider any additional guarantees proposed by the Customer, such as insurance on outstanding obligations.*









**02/2023**

Questo catalogo annulla e sostituisce ogni precedente edizione o revisione.

Tutti i dati elencati sono indicativi e s'intendono senza impegno alcuno da parte nostra.

Ci riserviamo il diritto di apportare modifiche senza preavviso.

*This catalogue cancels and replaces any previous edition and revision.*

*All listed data are approximate and it's understood that this entails no obligation on our part.*

*We reserve the right to implement modifications without notice.*

Mit der Ausgabe dieses Katalogs annullieren sich gleichzeitig alle bisherigen Katalogen.

Sämtliche Daten sind Berechnete Werte die für den Verkäufer unverbindlich sind.

Der Verkäufer behält sich das Recht vor, Änderungen, ohne eine vorhergehende Advisierung durchzuführen.

GAMME DI PRODOTTO  
RANGE OF PRODUCTS

Riduttori a vite senza fine / Worm gearboxes  
Riduttori a ingranaggi / Helical and bevel helical gearboxes  
Riduttori epicicloidali di precisione / Precision planetary gearboxes  
Riduttori speciali / Special gearboxes  
Variatori di velocità / Mechanical variators



84 h8

