

Worm Gear, In-line and Shaft Mounted Reducers

NEMA / INCH SERIES

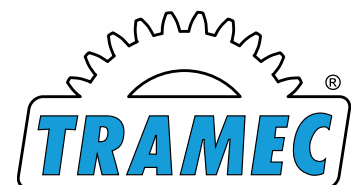

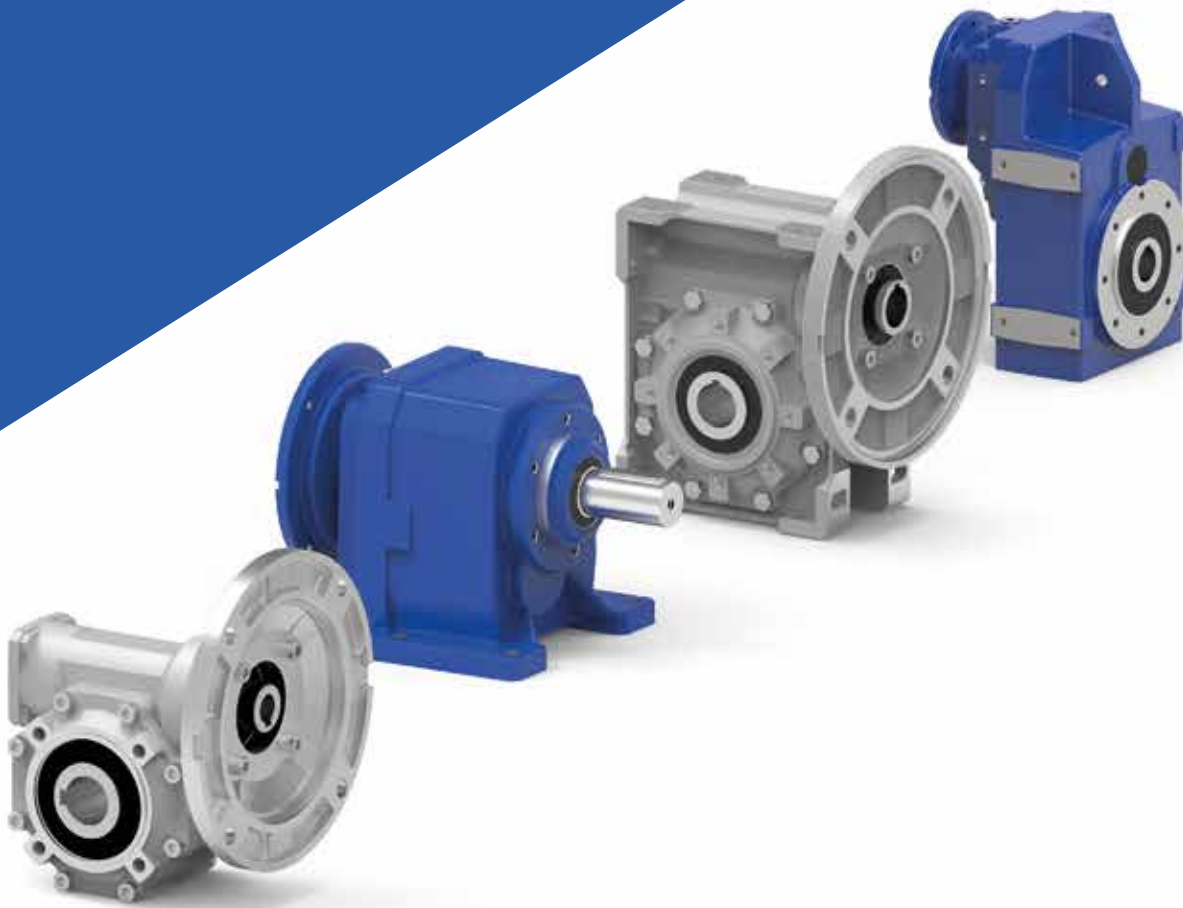
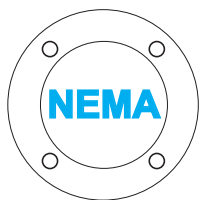

Index

Indice

Page
Pág.

A	Introduction	<i>Introducción</i>	A1
1.1	Measurement units	<i>Unidades de medida</i>	A2
1.2	Power	<i>Potencia</i>	A2
1.3	Reduction Ratio	<i>Relación de reducción</i>	A2
1.4	Torque	<i>Torque</i>	A2
1.5	Service factor	<i>Factor de servicio</i>	A3
1.6	Selection	<i>Selección</i>	A4
1.7	Lubrication	<i>Lubricación</i>	A4

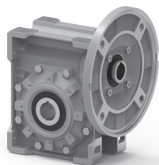

B	Worm gear reducers XN	<i>Reductores sinfin corona</i> XN	B1
----------	---------------------------------	--	-----------



C	Worm gear reducers KN	<i>Reductores sinfin corona</i> KN	C1
----------	---------------------------------	--	-----------



D	Helical gear reducers RCV	<i>Reductores de engranajes helicoidales</i> RCV	D1
----------	--	--	-----------

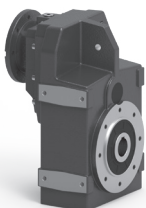

E	Shaft-mounted reducers RFV	<i>Reductores pendulares</i> RFV	E1
----------	--------------------------------------	--	-----------

1.1 Measurement units

1.1 Unidades de medida

Simbolo Symbol	Unità di misura Measurement unit	Definition	Definición
FS'		Gear reducer service factor	Factor de servicio del reductor
FS		Application service factor	Factor de servicio de la aplicación
i_1		Ratio of 1st gear reducer	Relación de reducción del 1° reductor
i_2		Ratio of 2nd gear reducer	Relación de reducción del 2° reductor
i_n		Reduction ratio	Relación de reducción
M_{2S}	[Ft•lb]	Slipping torque	Par de deslizamiento
n_1	[min ⁻¹]	Input speed	Velocidad de entrada
n_2	[min ⁻¹]	Output speed	Velocidad de salida
P	[Hp]	Gear reducer power	Potencia reductor
P'	[Hp]	Power required at input	Potencia de entrada requerida
P_1	[Hp]	Gear motor power	Potencia del motor reductor
P_2	[Hp]	Output power	Potencia de salida
P_{tc}	[Hp]	Corrected thermal power	Potencia térmica corregida
P_{to}	[Hp]	Thermal power	Potencia térmica nominal
F_{r1}	[lb]	Input shaft radial load	Carga radial del eje de entrada
F_{r2}	[lb]	Output shaft radial load	Carga radial del eje de salida
F_{a1}	[lb]	Input shaft axial load	Carga axial del eje de entrada
F_{a2}	[lb]	Output shaft axial load	Carga axial del eje de salida
Rd		Dynamic efficiency	Rendimiento dinámico
Rs		Static efficiency	Rendimiento estático
Ta	[°F]	Ambient temperature	Temperatura ambiente
T_{2M}	[Ft•lb]	Gear reducer torque	Torque del reductor
T_2	[Ft•lb]	Gear motor torque	Torque del motor reductor
T_c	[Ft•lb]	Torque to be used for the selection of the gear reducer	Torque para la elección del reductor
T_2'	[Ft•lb]	Required Torque	Torque requerido

1.2 Power

P = max. power applicable at input with male worm shaft, referred to n_1 speed, service factor FS=1, on S1 continuous duty.

P_1 = recommended motor power, referred to n_1 speed, service factor FS as reported in the table on page 4, on S1 continuous duty.

The necessary input power with regard to T_2 torque required by the application, is to be calculated with the following formula:

$$P' = \frac{T_2' \cdot n_2}{5200 \cdot Rd} \quad [\text{hP}]$$

1.3 Reduction Ratio

i_n = speed reduction ratio, defined as follows:

$$i_n = \frac{n_1}{n_2}$$

1.4 Torque

T_{2M} = max. torque transmissible at gear reducer output with uniform load, referred to n_1 speed, service factor FS = 1, on S1 continuous duty.

T_2 = output torque transmissible to the geared motor, referred to n_1 speed, P_1 power, FS service factor as reported in the table, on S1 continuous duty.

$$T_{2M} = \frac{5200 \cdot P_1 \cdot Rd}{n_2} \quad [\text{Ft} \cdot \text{lb}]$$

1.2 Potencia

P = Potencia máxima aplicable de entrada con tornillo y eje macho, en relación a la velocidad n_1 , con factor de servicio FS = 1 y servicio continuo S1.

P_1 = Potencia del motor aconsejable para la velocidad n_1 , con factor de servicio FS detallado en la tabla de la pag. 4 y servicio continuo S1.

Es factible determinar la potencia necesaria de entrada P', en base al par T_2' que la aplicación requiere con la siguiente fórmula:

1.3 Relación de reducción

i_n = Relación de velocidad, definida como:

1.4 Torque

T_{2M} = Máximo par transmisible de salida del reductor con carga uniforme, en relación a la velocidad n_1 , con factor de servicio FS = 1 y servicio continuo S1.

T_2 = Es el par de salida del motor reductor, en relación a la velocidad n_1 y la potencia P_1 , con factor de servicio FS = 1 detallado en la tabla y servicio continuo S1.

1.5 Service factor

Value which takes the different operating conditions into consideration:

- type of application or type of load (A-B-C)
- length of operation (hours per day h/d)
- number of start-ups/hour

This coefficient (FS) will have to be equal or lower than the FS of selected gear reducer FS' given by the ratio between T_{2M} torque mentioned in the catalogue and the T_2 torque required by the application.

$$FS' = \frac{T_{2M}}{T_2} > FS$$

FS values reported in the table refer to the electric motor operation; should a combustion motor be used, consider a multiplication factor of 1.3 for a multicylinder motor, of 1.5 for a single-cylinder one. If an electric brake motor is used, consider a number of start-ups which is twice as much the number actually required.

1.5 Factor de servicio

Es el valor que considera las varias condiciones de funcionamiento:

- Tipología de aplicación o naturaleza de la carga (A-B-C)
- tiempo de funcionamiento (horas diarias h/d)
- número de arranques/hora

El coeficiente hallado (FS) deberá ser igual o menor al factor de servicio a adaptar FS' en relación con el par T_{2M} indicado en el catálogo, y el par T_2 requerido por la aplicación.

El valor FS indicados en la tabla son relativos al accionar del motor eléctrico; si se utiliza un motor a explosión, se deberá tener en cuenta un factor multiplicativo 1.3 para varios cilindros y 1.5 para un cilindro.

Si el motor eléctrico aplicado es autofrenante se considere el doble de arranques de lo que efectivamente se requiere.

Load class Clase de carga	h/d h/d	N. START-UP/HOUR - N. ARRANQUE/HORA								
		2	4	8	16	32	63	125	250	500
A	4	0.8	0.8	0.9	0.9	1.0	1.1	1.1	1.2	1.2
	8	1.0	1.0	1.1	1.1	1.3	1.3	1.3	1.3	1.3
	16	1.3	1.3	1.3	1.3	1.5	1.5	1.5	1.5	1.5
	24	1.5	1.5	1.5	1.5	1.8	1.8	1.8	1.8	1.8
	APPLICATIONS / APLICACIONES									
Uniform load <i>Carga con choques moderados</i>	Pure liquid agitators					Agitadores para líquidos puros				
	Furnace feeders					Alimentadores para hornos				
	Disc feeders					Alimentadores para disco				
	Air laundry filters					Filtros de lavado neumáticos				
	Generators					Generadores				
Centrifugal pumps					Bombas centrífugas					
Uniform load conveyors					Transportadores de carga uniforme					
Load class Clase de carga	h/d h/d	N. START-UP/HOUR - N. ARRANQUE/HORA								
		2	4	8	16	32	63	125	250	500
B	4	1.0	1.0	1.0	1.0	1.3	1.3	1.3	1.3	1.3
	8	1.3	1.3	1.3	1.3	1.5	1.5	1.5	1.5	1.5
	16	1.5	1.5	1.5	1.5	1.8	1.8	1.8	1.8	1.8
	24	1.8	1.8	1.8	1.8	2.2	2.2	2.2	2.2	2.2
	APPLICATIONS / APLICACIONES									
Moderate shock load <i>Carga con choques moderados</i>	Liquid and solid agitators					Agitadores para líquidos y sólidos				
	Belt conveyors					Cintas alimentadoras				
	Medium service winches					Cebestante de servicio medio				
	Stone and gravel filters					Filtros de grava				
	Dewatering screws					Tornillos de evacuación de agua				
Flocculator					Flocculadores					
Vacuum filters					Filtros de vacío					
Bucket elevators					Elevadores a cangilones					
Cranes					Grúas					
Load class Clase de carga	h/d h/d	N. START-UP/HOUR - N. ARRANQUE/HORA								
		2	4	8	16	32	63	125	250	500
C	4	1.3	1.3	1.3	1.3	1.5	1.5	1.5	1.5	1.5
	8	1.5	1.5	1.5	1.5	1.8	1.8	1.8	1.8	1.8
	16	1.8	1.8	1.8	1.8	2.2	2.2	2.2	2.2	2.2
	24	2.2	2.2	2.2	2.2	2.5	2.5	2.5	2.5	2.5
	APPLICAZIONI / APPLICATIONS / ANWENDUNGEN									
Heavy shock load <i>Carga con choques fuertes</i>	Heavy duty hoists					Cabrestante de servicio pesado				
	Extruders					Extrusoras				
	Crusher rubber calenders					Calandras				
	Brick presses					Presas para ladrillos				
	Planing machine					Planeadoras				
Ball mills					Molinos de bolas					

1.6 Selection

Selecting a gear reducer

A) $n_1 = 1750 \text{ min}^{-1}$

Consult the gear reducer unit efficiency table; select a group whose ratio is close to the calculated ratio and which permits power:

$$P \geq P' \cdot FS'$$

Selecting a gearmotor

B) $FS = 1$

Consult the gear motor efficiency table and select a group having power P1 corresponding to calculated P'.

C) $FS \neq 1$

Follow the instructions at point A), checking that the size of the motor to be installed is compatible with the gear reducer unit (IEC); obviously, installed power must correspond to the required P' value.

After having selected the proper gear reducer, it is necessary to check out that possible additional loads (radial or axial) on the input and /or output shafts fall within the values reported in the catalogue. Depending on the application, it might be necessary to check that the power absorbed by the gear reducer does not exceed the thermal power limit reported in the tables of technical data.

1.7 Lubrication

All worm gear reducers XN, KN, RFV and RCV series, are supplied with synthetic lubricant, PAG base, viscosity index ISO VG 320.

Only for series XN and KN, the bearings mounted on the input shaft are always supplied with synthetic -base grease for all mounting positions. For mounting positions B6 - B7, the output shaft bearings are also greased to ensure correct lubrication. This means that it is possible to switch from the mounting positions B6 - B7 to all the other positions, changing only the quantities of oil specified in the corresponding tables. Mounting positions B3 - B8 - V5 - V6 can be exchanged without changing the oil quantity.

Choose the lubricant according to operating and ambient conditions in order to ensure high gear unit performance.

Performance data, as shown in the specifications tables, refer to utilization of synthetic oil.

VISCOSITY

It is one of the most important parameters to be considered when selecting an oil; it depends on various factors such as speed and temperature. Following are general guidelines for choosing the correct viscosity:

High viscosity

To be used for low rotation speed and/or high temperatures. (Under these operating conditions a low viscosity causes premature wear).

Low viscosity

To be used for high rotation speed and/or low temperatures. (High viscosity reduces efficiency and causes overheating).

1.6 Selección

Selección del reductor

A) $n_1 = 1750 \text{ min}^{-1}$

Se elegirá en las tablas de prestaciones de los reductores aquellos que en base a la relación calculada admitan una potencia:

Selección del motor reductor

B) $FS = 1$

Consultar en la tabla de prestaciones los motores reductores cuya potencia P1 corresponda a la P' calculada.

C) $FS \neq 1$

La selección deberá realizarse como en el punto A) verificando que el tamaño del motor a instalar sea compatible con los admitidos por el reductor (IEC); lógicamente la potencia instalada deberá corresponder al valor P' requerido.

Determinado el reductor idóneo es necesario verificar que las posibles cargas adicionales (radiales y axiales), agentes sobre el eje de salida y/o de entrada, estén comprendidos entre los valores admisibles por el catálogo.

En determinadas condiciones aplicables, puede llegar a ser necesario verificar que la potencia absorbida por el reductor no supere el límite térmico señalado en el catálogo, según cuanto se indica en tablas de datos técnicos.

1.7 Lubricación

Los reductores de la serie XN, KN, RFV y RCV se entregan completos de lubricante sintético a base PAG con viscosidad ISO VG320.

Solo para la serie XN y KN, los rodamientos del eje de entrada siempre están lubricados con grasa de base sintética para todas las posiciones de montaje, solo para las posiciones de montaje B6 - B7, para una lubricación adecuada, los rodamientos del eje de salida también están engrasados. Esto significa que solo desde las posiciones de montaje B6 - B7 es posible cambiar a todas las otras posiciones, modificando solo las cantidades de aceite, como se indica en las tablas relativas; en cuanto a las posiciones de montaje B3 - B8 - V5 - V6, solo pueden ser intercambiables entre ellas, sin cambiar las cantidades de aceite.

La elección cuidadosa del tipo de lubricante, en función de las condiciones operativas y ambientales, permite que los reductores alcancen las óptimas prestaciones.

Las prestaciones de los reductores, indicadas en la tabla de los datos técnicos, fueron calculadas considerando el empleo del aceite sintético.

VISCOSIDAD

Es uno de los parámetros más importantes a tener en cuenta a la hora de seleccionar un aceite, ya que influye directamente en factores tales como la velocidad y la temperatura. A continuación sintetizaremos las líneas generales para la elección de la correcta viscosidad:

Viscosidad alta

Usar para bajas velocidades de rotación y/o altas temperaturas. (Una viscosidad demasiado baja en estas condiciones operativas provoca un desgaste prematuro).

Viscosidad baja

Usar para altas velocidades de rotación y/o bajas temperaturas. (Una viscosidad demasiado alta, reduce la eficiencia y provoca recalentamiento).

ADDITIVES

All mineral oils contain additives to protect against wear, EP (more or less strong), anti-oxidizing and anti-frothing. It is advisable to make sure that the action of such additives is bland and not too aggressive on the seals.

OIL BASE

May be mineral or synthetic. Synthetic oil compensates for the higher cost with a series of advantages :

- lower friction coefficient (consequently improved efficiency)
- better stability over time (possible life lubrication)
- better viscosity index (more adaptable to various temperatures).

Mineral-base oils offer the advantages of costing less and performing better during the running-in period.

ADITIVOS

Todos los aceites minerales contienen aditivos antidesgaste, EP (mas o menos energéticos), antioxidantes y antiespumantes. Es conveniente asegurarse de que estos sean blandos y no agresivos ya que podrían dañar las juntas.















BASE DEL ACEITE

Puede ser sintético o mineral.

El aceite sintético compensa su mayor coste con una serie de ventajas:

- Menor coeficiente de fricción (por consecuencia mayor rendimiento)
- Mejor estabilidad en el tiempo (posible lubricación de por vida)
- Mejor índice de viscosidad (mejor adaptabilidad a varias temperaturas).

El aceite de base mineral es ventajoso por tener un menor coste y un mejor comportamiento en rodaje.

ISO VG	MINERAL OIL / ACEITE MINERAL			SYNTHETIC OIL / ACEITE SINTÉTICO					
	460	320	220	460	320	220	150		
Amb.Temp. Temperatura ambiente Ta (°F)	41° a 113°	32° a 104°	23° a 95°	5° a 140°	-4° a 122°	-13° a 113°	-22° a 104°		
MANUFACTURER / PROVEEDOR	MINERAL / MINERAL								
	SHELL		Omala OIL 460	Omala OIL 320	Omala OIL 220				
	BP		Energol GRXP 460	Energol GRXP 320	Energol GRXP 220				
	TEXACO		Meropa 460	Meropa 320	Meropa 220				
	CASTROL		Alpha SP 460	Alpha SP 320	Alpha SP 220				
	KLUBER		Lamora 460	Lamora 320	Lamora 220				
	MOBIL		Mobilgear 634	Mobilgear 632	Mobilgear 630				
	PAG Technology (polyalkyleneglycol) / PAG (polialkilenglicol)								
	SHELL					Omala S4 WE 460	Omala S4 WE 320	Omala S4 WE 220	Omala S4 WE 150
	BP					Energol SGXP460	Energol SGXP320	Energol SGXP220	Energol SG 150
	TEXACO					Synlube CLP 460	Synlube CLP 320	Synlube CLP 220	
	AGIP						Agip Blasias S 320	Agip Blasias S 220	Agip Blasias S 150
	PAO Technology (polialphaolefin) / PAO (polialfaolefina)								
	SHELL					Omala OIL RL/HD 460	Omala OIL RL/HD 320	Omala OIL RL/HD 220	Omala OIL RL/HD 150
	CASTROL					Alpha Synt 460	Alpha Synt 320	Alpha Synt 220	Alpha Synt 150
KLUBER					Synteso D460 EP	Synteso D320 EP	Synteso D220 EP	Synteso D150 EP	
MOBIL					SHC 634	SHC 632	SHC 630	SHC 629	

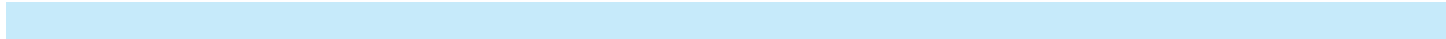

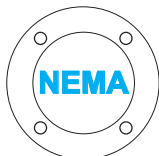

B

Worm gear reducers
XN

Reductores sinfin corona
XN

B1

INDEX

INDICE

2.1	Characteristics	<i>Características</i>	B2
2.2	Designation	<i>Nomenclatura</i>	B3
2.3	Lubrication	<i>Lubricación</i>	B4
2.4	Terminal board position	<i>Posición de la caja de bornes</i>	B4
2.5	Radial load	<i>Cargas radiales</i>	B5
2.6	Technical data	<i>Datos técnicos</i>	B6
2.7	Dimensions	<i>Dimensiones</i>	B8
2.8	Accessories	<i>Accesorios</i>	B13

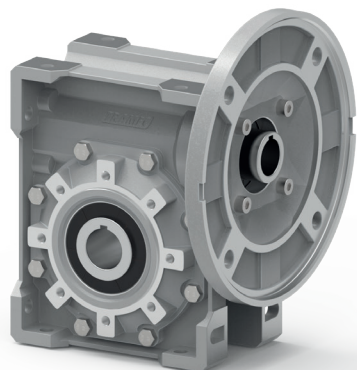

XNC..

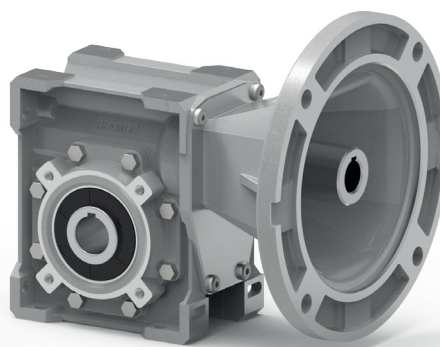

XNF..



Worm gear reducers

XN

2.1 Characteristics

- XN series worm gear reducers are available in the following versions: XNF (only size 40) and XNC (all sizes except 40) suitable for motor mounting assembling.
- The XNF version (bell + joint) suits a wider range of applications and provides higher efficiency than the XNC compact version, which actually offers reduced space requirement.
- The enbloc housing is in cast-iron for size 90, in die-cast aluminium for sizes 40, 50, 63, 75 and 89.
- The worm shaft is in case-and quenchhardened alloy steel and ground.
- The worm wheel has a cast-iron hub provided with inserted cast-bronze ring.
- The cast-iron housings are painted BLUE RAL5010 whereas the aluminium housings are sandblasted.
- The hollow output shaft is supplied as standard. A broad range of accessories is available: tapered roller bearings on the worm wheel, output flange, single or double-extended output shaft, torque arm, output bore protection kit.

Reductores sinfin corona

XN

2.1 Características

- Los reductores de sinfin corona de la serie XN están disponibles en las versiones: XNF (solo tamaño 40) y XNC (todos los tamaños excepto 40) adecuados para el montaje del motor.
- La versión XNF (campana + junta), caracterizada por una amplia versatilidad en los distintos tipos de aplicaciones, presenta un mayor rendimiento con respecto a la serie XNC, que a su vez, tiene la ventaja de ocupar un espacio menor.
- La carcasa monobloque es de hierro fundido para el tamaño 90 y para los tamaños inferiores de aluminio fundido bajo presión.
- Los tornillos sin fin son de acero aleado cementado templado y son rectificadas.
- Los dientes de los engranajes realizados en hierro fundido y el anillo en bronce.
- Las carcasas en hierro fundido pintadas de AZUL RAL 5010 mientras que las de aluminio pulidas a chorro de arena.
- Está incluido el eje de salida hueco de serie, con una amplia disponibilidad de accesorios: cojinetes de bolas sobre el engranaje, brida de salida, eje lento con 1 y dos salidas, brazo de reacción, kit de protección eje hueco.

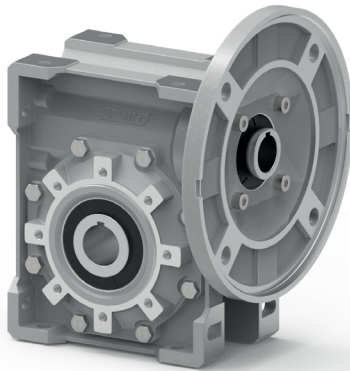

XNC..

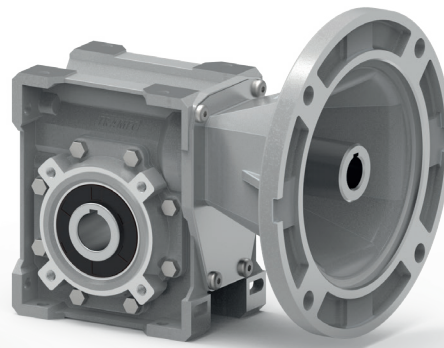





XNF..



2.2 Designation

2.2 Nomenclatura

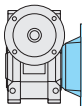
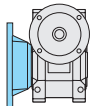
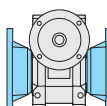
Gear reducer Reductores	Input type Tipo entrada	Size Tamaño	Ratio Relación redu.	Motor coupling Enganche motor.	Mounting position Posición montaje	Hollow output shaft Eje hueco de salida	Output flange Brida de salida
XN	C	50	10/1	NEMA	B3	H25.4	F1S
Worm gear reducer Reductores de sinfin corona	 C  F	 Aluminium Aluminio 40 ⁽¹⁾ 50 ⁽²⁾ 63 ⁽²⁾ 75 ⁽²⁾ 89 ⁽²⁾ <hr/>  Cast iron Hierro fundido 90 ⁽²⁾	5 7.5 10 15 20 25 30 40 50 65 80 100	56C 143 TC 145 TC 182 TC 184 TC	B3, B6 B7, B8 V5, V6	see tables <i>ver tablas</i> 	 F1D-F2D-F3D  F1S-F2S-F3S  F12-F22-F32

(1): only with input type F
 (2): only with input type C

(1): solo con entrada tipo F
 (2): solo con entrada tipo C

Input type

Tipo entrada

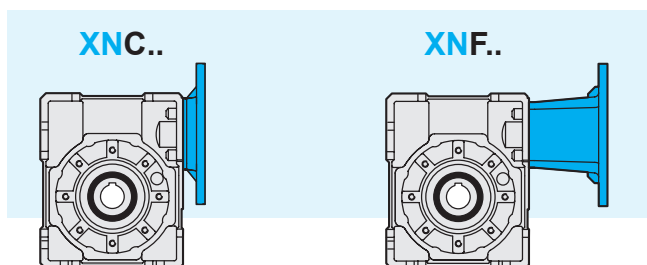



2.3 Lubrication

XN series worm gear reducers are supplied with synthetic lubricant, PAG base, viscosity index ISO VG320. Mounting position always to be specified when ordering.

For more details, see page A5, paragraph 1.7.

2.3 Lubricación

Los reductores de la serie XN se entregan completos de lubricante sintético a base PAG con viscosidad ISO VG320. Se ruega precisar la posición de montaje deseada a la hora de realizar el pedido.

Para más detalles ver página A5 párrafo 1.7

Mounting positions

Posición de montaje

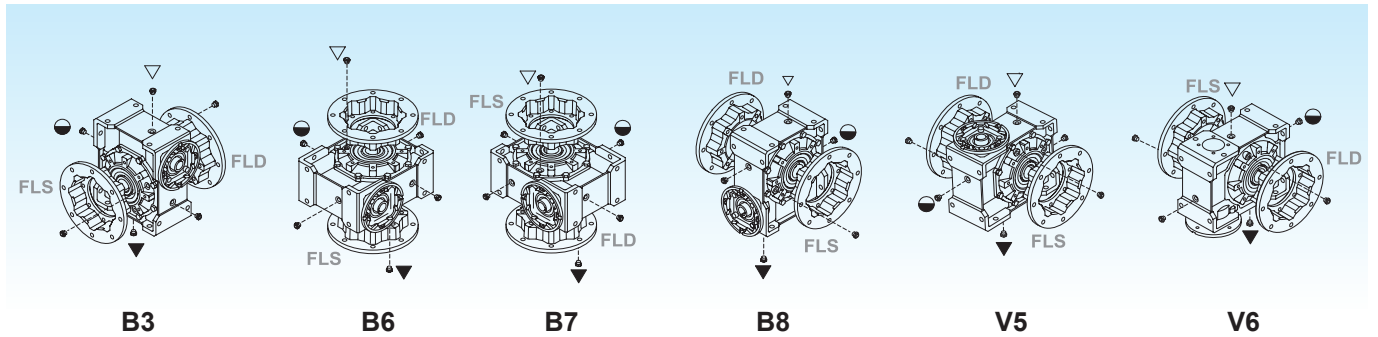

- ▽ Filling and breather / Carga y respiradero
- Level / Nivel
- ▼ Drain / Descarga

30, 40, 50, 63, 75 and 89 aluminium housings have one oil filling plug only.

Los cuerpos de aluminio 30, 40, 50, 63, 75 y 89 tiene solamente un tapón de llenado para aceite.

gal [lt]		Oil quantity / Cant. de aceite			
		Mounting position / Posición de montaje			
		B3	B6 - B7	B8	V5 - V6
XN	40	0.011 [0.04]	0.016 [0.06]	0.011 [0.04]	
	50	0.021 [0.08]	0.032 [0.12]	0.021 [0.08]	
	63	0.042 [0.16]	0.058 [0.22]	0.042 [0.16]	
	75	0.069 [0.26]	0.090 [0.34]	0.069 [0.26]	
	89	0.119 [0.45]	0.198 [0.75]	0.119 [0.45]	
	90	0.290 [1.1]	0.238 [0.9]	0.264 [1]	0.396 [1.5]

2.4 Terminal board position

2.4 Posición borne

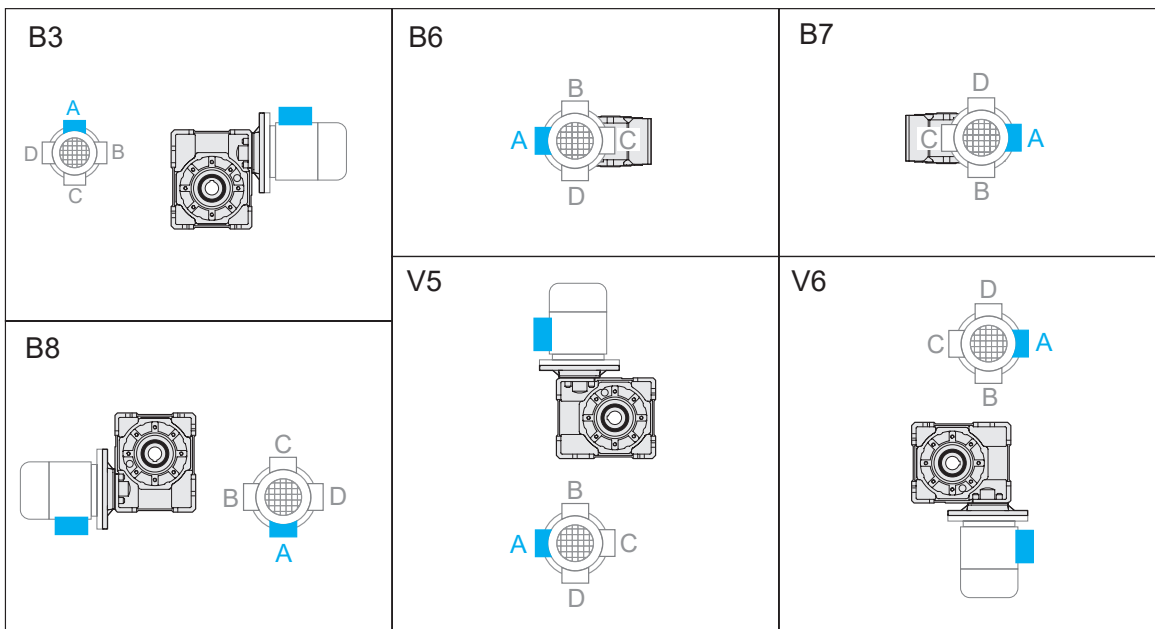

Mounting position always to be specified when ordering. Terminal board position see page B11 (PM=1)

A la hora de realizar el pedido se ruega precisar la posición de montaje y la posición de la caja de bornes. Posición borne v. pág. B11 (PM=1)



2.5 Radial load

Any transmission device coupled to the output shaft generates radial loads Fr_2 .

The load values reported in the table, depending on input and output speed, are to be considered as acting at the half-way point of the projection; if the load is applied at 1/3 of the projection, increase the values in the table by 25%; if the load is applied at 2/3, reduce the values by 25%.

Axial loads applicable at output Fa_2 are reported in the tables.

With regard to double projecting shafts, each end can sustain a radial load which equals 3/5 of the values listed in the table, on condition that they act in the same direction and have the same intensity.

2.5 Cargas radiales

Cada clase de órgano de transmisión que es conectado al eje de salida determina cargas radiales Fr_2 .

Los valores señalados en la tabla en función a las varias velocidades de entrada y salida se suponen aplicándolas en la mitad del eje como fuerzas agentes a esta; para una ubicación de 1/3 de la longitud se aumentará hasta un 25% los valores de la tabla, mientras para una posición de 2/3 de la longitud se disminuirá los mismos valores a un 25%.

Los valores de las cargas axiales aplicables en salida F_{a2} están señalados en las tablas.

En los ejes con salida doble, cada extremidad puede soportar una carga radial igual a 3/5 del valor de la tabla, siempre y cuando las cargas aplicables sean de igual intensidad y reaccionen en el mismo sentido.

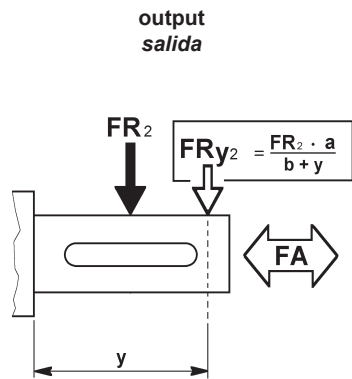

RADIAL BALL BEARINGS / RODAMIENTOS RADIALES														
$n_1=1750$ rpm		40		50		63		75		89		90		
i_n	n_2 [rpm]	a b		a b		a b		a b		a b		a b		
		inch	mm	inch	mm	inch	mm	inch	mm	inch	mm	inch	mm	
		Fr_2	Fa_2	Fr_2	Fa_2	Fr_2	Fa_2	Fr_2	Fa_2	Fr_2	Fa_2	Fr_2	Fa_2	
5	350	lbf	777	155	777	166	999	200	/		/		/	
		[N]	[1400]	[280]	[1400]	[300]	[1800]	[360]						
7.5	233	lbf	832	166	915	183	1165	233	1387	277	1442	288	1442	288
		[N]	[1500]	[300]	[1650]	[330]	[2100]	[420]	[2500]	[500]	[2600]	[520]	[2600]	[520]
10	175	lbf	888	178	999	200	1276	255	1553	311	1664	333	1664	333
		[N]	[1600]	[320]	[1800]	[360]	[2300]	[460]	[2800]	[560]	[3000]	[600]	[3000]	[600]
15	117	lbf	943	189	1082	216	1442	288	1664	333	1886	377	1886	377
		[N]	[1700]	[340]	[1950]	[390]	[2600]	[520]	[3000]	[600]	[3400]	[680]	[3400]	[680]
20	87.5	lbf	999	200	1221	244	1553	311	1831	366	2108	422	2108	422
		[N]	[1800]	[360]	[2200]	[440]	[2800]	[560]	[3300]	[660]	[3800]	[760]	[3800]	[760]
25	70	lbf	1054	211	1332	266	1720	344	2053	411	2275	455	2275	455
		[N]	[1900]	[380]	[2400]	[480]	[3100]	[620]	[3700]	[740]	[4100]	[820]	[4100]	[820]
30	58	lbf	1110	222	1442	288	1886	377	2219	444	2497	499	2497	499
		[N]	[2000]	[400]	[2600]	[520]	[3400]	[680]	[4000]	[800]	[4500]	[900]	[4500]	[900]
40	44	lbf	1165	233	1581	316	2053	411	2441	488	2719	544	2719	544
		[N]	[2100]	[420]	[2850]	[570]	[3700]	[740]	[4400]	[880]	[4900]	[980]	[4900]	[980]
50	35	lbf	1221	244	1720	344	2219	444	2691	538	2940	588	2940	588
		[N]	[2200]	[440]	[3100]	[620]	[4000]	[800]	[4850]	[970]	[5300]	[1060]	[5300]	[1060]
60	29	lbf	1332	266	1775	355	2330	466	2774	555	3107	621	3107	621
		[N]	[2400]	[480]	[3200]	[640]	[4200]	[840]	[5000]	[1000]	[5600]	[1120]	[5600]	[1120]
63	28	lbf	1387	277	1886	377	2469	494	2940	588	3273	655	3273	655
		[N]	[2500]	[500]	[3400]	[680]	[4450]	[890]	[5300]	[1060]	[5900]	[1180]	[5900]	[1180]
80	22	lbf	1498	300	2108	422	2719	544	3218	644	3606	721	3606	721
		[N]	[2700]	[540]	[3800]	[760]	[4900]	[980]	[5800]	[1160]	[6500]	[1300]	[6500]	[1300]
100	17.5	lbf	1664	333	2219	444	2996	599	3606	721	3884	777	3884	777
		[N]	[3000]	[600]	[4000]	[800]	[5400]	[1080]	[6500]	[1300]	[7000]	[1400]	[7000]	[1400]
120	15	lbf	1720	344	2275	455	3051	610	3634	727	3939	788	3939	788
		[N]	[3100]	[620]	[4100]	[820]	[5500]	[1100]	[6550]	[1310]	[7100]	[1420]	[7100]	[1420]
150	12	lbf	1748	350	2358	472	3107	621	3662	732	4050	810	4050	810
		[N]	[3150]	[630]	[4250]	[850]	[5600]	[1120]	[6600]	[1320]	[7300]	[1460]	[7300]	[1460]
160	11	lbf	1775	355	2386	477	3162	632	3717	743	4106	821	4106	821
		[N]	[3200]	[640]	[4300]	[860]	[5700]	[1140]	[6700]	[1340]	[7400]	[1480]	[7400]	[1480]
≥ 200	≤ 9	lbf	1831	366	2497	499	3329	666	3939	788	4383	877	4383	877
		[N]	[3300]	[660]	[4500]	[900]	[6000]	[1200]	[7100]	[1420]	[7900]	[1580]	[7900]	[1580]



2.6 Technical data

2.6 Datos técnicos

40	$n_1 = 1750$				XNF					
	i_n	n_2 [min ⁻¹]	Rd	P_{10} [Hp]	T_2		P_1		FS'	NEMA
					[Ft·lb]	[Nm]	[Hp]	[kW]		
5.3	5	350	0.87	1.1	10	13	0.75	0.55	2.6	56 C
	7.5	233	0.85	1.1	14	19	0.75	0.55	2.1	
	10	175	0.83	0.9	18	25	0.75	0.55	1.6	
	15	117	0.79	0.7	18	24	0.50	0.37	1.8	
	20	88	0.76	0.7	23	31	0.50	0.37	1.3	
	25	70	0.72	0.5	18	25	0.33	0.25	1.4	
	30	58	0.68	0.5	21	28	0.33	0.25	1.5	
	40	44	0.64	0.4	18	25	0.25	0.18	1.5	
	50	35	0.59	0.4	21	29	0.25	0.18	1.3	

50	$n_1 = 1750$				XNC					
	i_n	n_2 [min ⁻¹]	Rd	P_{10} [Hp]	T_2		P_1		FS'	NEMA
					[Ft·lb]	[Nm]	[Hp]	[kW]		
8.8	5	350	0.87	1.6	10	13	0.75	0.55	4.8	56 C
	7.5	233	0.86	1.6	14	19	0.75	0.55	3.7	
	10	175	0.84	1.3	18	25	0.75	0.55	2.9	
	15	117	0.80	1.1	27	36	0.75	0.55	2.1	
	20	88	0.78	0.9	35	47	0.75	0.55	1.6	
	25	70	0.74	0.8	27	37	0.50	0.37	1.8	
	30	58	0.71	0.8	32	43	0.50	0.37	1.5	
	40	44	0.67	0.7	40	54	0.50	0.37	1.3	
	50	35	0.62	0.5	31	42	0.33	0.25	1.7	
	65	27	0.58	0.5	38	51	0.33	0.25	1.3	
80	22	0.54	0.5	31	42	0.25	0.18	1.4		

63	$n_1 = 1750$				XNC							
	i_n	n_2 [min ⁻¹]	Rd	P_{10} [Hp]	T_2		P_1		FS'	NEMA		
					[Ft·lb]	[Nm]	[Hp]	[kW]				
14.6	5	350	0.88	2.4	27	36	2.0	1.5	3.1	56 C	143 TC	145 TC
	7.5	233	0.87	2.4	39	53	2.0	1.5	2.3			
	10	175	0.85	2.1	51	70	2.0	1.5	1.8			
	15	117	0.81	1.6	73	99	2.0	1.5	1.3			
	20	88	0.80	1.6	70	96	1.5	1.1	1.5			
	25	70	0.77	1.3	58	79	1.0	0.75	1.5			
	30	58	0.73	1.2	67	90	1.0	0.75	1.6			
	40	44	0.69	1.1	83	112	1.0	0.75	1.3			
	50	35	0.65	0.9	72	98	0.75	0.55	1.2			
	65	27	0.61	0.8	59	80	0.50	0.37	1.5			
	80	22	0.58	0.8	46	63	0.33	0.25	1.8			
100	18	0.53	0.7	52	70	0.33	0.25	1.5				

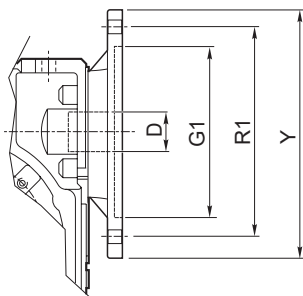

		NEMA	
		56C	143TC - 145TC
G1	in [mm]	4 1/2" [114.3]	
R1	in [mm]	5 7/8" [149.22]	
Y	in [mm]	6 1/2" [165.10]	
D	in [mm]	5/8" [15.875]	7/8" [22.225]

* **WARNING:** Maximum allowable torque [T_{2M}] must be calculated using the following service factor : $T_{2M} = T_2 \times FS'$

* **ATENCION:** el par máximo utilizable [T_{2M}] deberá calcularse con respecto al factor de servicio : $T_{2M} = T_2 \times FS'$



2.6 Technical data

2.6 Datos técnicos

75	$n_1 = 1750$				XNC									
	i_n	n_2 [min ⁻¹]	Rd	P_{10} [Hp]	T_2		P_1		FS'	NEMA				
					[Ft·lb]	[Nm]	[Hp]	[kW]		143 TC		145 TC	182 TC	184 TC
19.8 	7.5	233	0.87	3.4	94	128	5.0	3.6	1.4	—	143 TC	145 TC	182 TC	184 TC
	10	175	0.86	3.1	76	103	3.0	2.2	1.9					
	15	117	0.83	2.5	110	149	3.0	2.2	1.4					
	20	88	0.81	2.3	97	132	2.0	1.5	1.7					
	25	70	0.78	2.0	118	160	2.0	1.5	1.3					
	30	58	0.74	1.6	99	134	1.5	1.1	1.6	56 C	—	—	—	—
	40	44	0.71	1.5	125	170	1.5	1.1	1.4					
	50	35	0.67	1.3	101	137	1.0	0.75	1.5					
	65	27	0.63	1.2	91	123	0.75	0.55	1.6					
	80	22	0.60	1.1	106	143	0.75	0.55	1.3					
100	18	0.56	0.9	120	163	0.75	0.55	1.0	—	—	—	—	—	

89	$n_1 = 1750$				XNC									
	i_n	n_2 [min ⁻¹]	Rd	P_{10} [Hp]	T_2		P_1		FS'	NEMA				
					[Ft·lb]	[Nm]	[Hp]	[kW]		143 TC		145 TC	182 TC	184 TC
28.7 	7.5	233	0.88	4.0	96	130	5.0	3.6	2.2	—	—	—	182 TC	184 TC
	10	175	0.86	3.4	125	169	5.0	3.6	1.8					
	15	117	0.84	3.0	111	151	3.0	2.2	2.1					
	20	88	0.82	2.7	145	196	3.0	2.2	1.8					
	25	70	0.80	2.4	177	240	3.0	2.2	1.4					
	30	58	0.76	2.0	203	275	3.0	2.2	1.3	56 C	143 TC	145 TC	—	—
	40	44	0.72	1.7	173	234	2.0	1.5	1.6					
	50	35	0.69	1.5	208	282	2.0	1.5	1.3					
	65	27	0.65	1.3	187	253	1.5	1.1	1.3					
	80	22	0.63	1.3	151	205	1.0	0.75	1.5					
100	18	0.58	1.1	125	169	0.75	0.55	1.6	—	—	—	—	—	

90	$n_1 = 1750$				XNC									
	i_n	n_2 [min ⁻¹]	Rd	P_{10} [Hp]	T_2		P_1		FS'	NEMA				
					[Ft·lb]	[Nm]	[Hp]	[kW]		143 TC		145 TC	182 TC	184 TC
52.0 	7.5	233	0.88	4.0	96	130	5.0	3.6	2.2	—	—	—	182 TC	184 TC
	10	175	0.86	3.4	125	169	5.0	3.6	1.8					
	15	117	0.84	3.0	111	151	3.0	2.2	2.1					
	20	88	0.82	2.7	145	196	3.0	2.2	1.8					
	25	70	0.80	2.4	177	240	3.0	2.2	1.4					
	30	58	0.76	2.0	203	275	3.0	2.2	1.3	56 C	143 TC	145 TC	—	—
	40	44	0.72	1.7	173	234	2.0	1.5	1.6					
	50	35	0.69	1.5	208	282	2.0	1.5	1.3					
	65	27	0.65	1.3	187	253	1.5	1.1	1.3					
	80	22	0.63	1.3	151	205	1.0	0.75	1.5					
100	18	0.58	1.1	125	169	0.75	0.55	1.6	—	—	—	—	—	

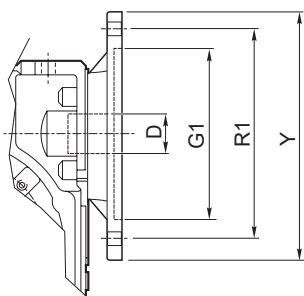

		NEMA		
		56C	143TC - 145TC	182TC - 184 TC
G1	in [mm]	4 1/2" [114.3]		8 1/2" [215.9]
R1	in [mm]	5 7/8" [149.22]		7 1/4" [184.15]
Y	in [mm]	6 1/2" [165.10]		9" [228.6]
D	in [mm]	5/8" [15.875]	7/8" [22.225]	1 1/8" [28.575]

* **WARNING:** Maximum allowable torque [T_{2M}] must be calculated using the following service factor : $T_{2M} = T_2 \times FS'$

* **ATENCIÓN:** el par máximo utilizable [T_{2M}] deberá calcularse con respecto al factor de servicio: $T_{2M} = T_2 \times FS'$



2.7 Dimensions

2.7 Dimensiones

XNF

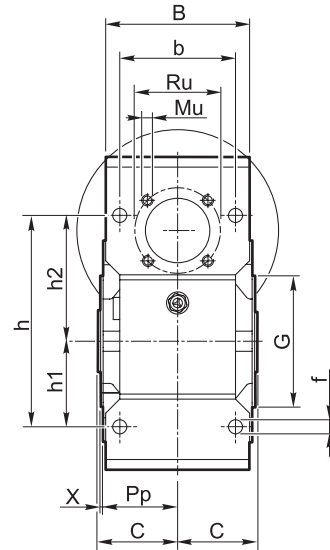
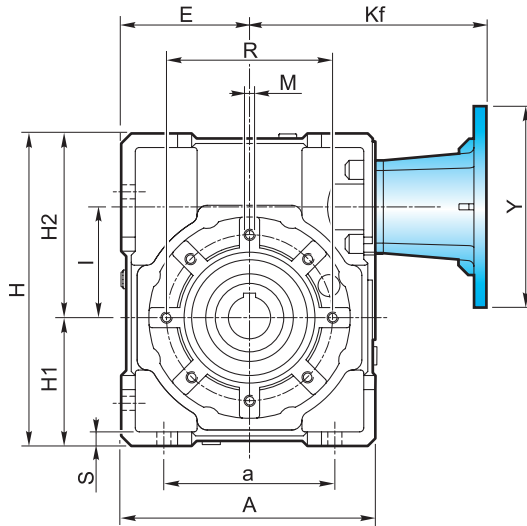

XNC

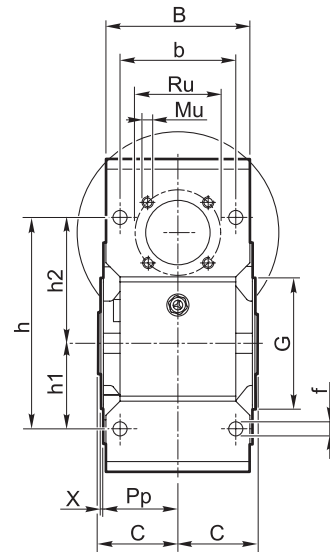
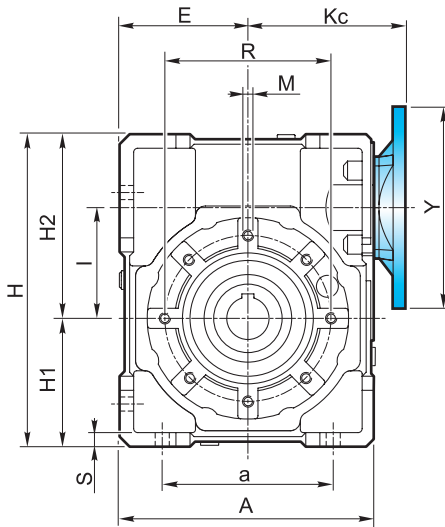

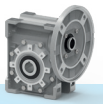

2.7 Dimensions

2.7 Dimensiones

Shaft-mounted flange / Brida pendular

40 - 50

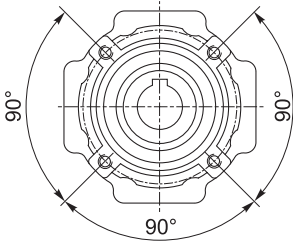

4 Holes / Agujeros

63 - 75 - 89 - 90

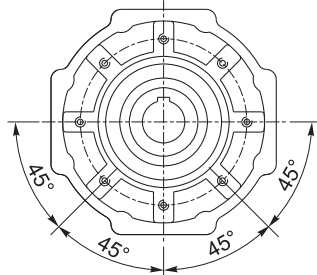

8 Holes / Agujeros

Output hollow shaft
Eje hueco de salida

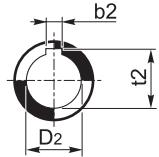

XN		A	a	B	b	b ₂	C	D ₂ H ₈	E	f	G h ₈	H	H ₁	H ₂	h	h ₁	h ₂
40	in	4.134	2.756	2.795	2.362	3/16"	1.535	3/4"	1.969	0.256	2.362	4.921	1.969	2.953	3.543	1.378	2.165
	[mm]	[105]	[70]	[71]	[60]	[4.762]	[39]	[19.05]	[50]	[6.5]	[60]	[125]	[50]	[75]	[90]	[35]	[55]
50	in	4.921	3.150	3.346	2.756	1/4"	1.811	1"	2.362	0.335	2.756	5.906	2.362	3.543	4.094	1.575	2.520
	[mm]	[125]	[80]	[85]	[70]	[6.35]	[46]	[25.4]	[60]	[8.5]	[70]	[150]	[60]	[90]	[104]	[40]	[64]
63	in	5.787	3.937	4.055	3.346	1/4"	2.205	1"	2.835	0.354	3.150	7.165	2.835	4.331	5.118	1.969	3.150
	[mm]	[147]	[100]	[103]	[85]	[6.35]	[56]	[25.4]	[72]	[9]	[80]	[182]	[72]	[110]	[130]	[50]	[80]
75	in	6.929	4.724	4.409	3.543	1/4"	2.362	1 1/4"	3.386	0.433	3.740	8.642	3.386	5.256	6.024	2.362	3.661
	[mm]	[176]	[120]	[112]	[90]	[6.35]	[60]	[31.75]	[86]	[11]	[95]	[219.5]	[86]	[133.5]	[153]	[60]	[93]
89	in	7.992	5.512	5.118	3.937	5/16"	2.756	1 3/8"	4.055	0.512	4.331	9.783	4.055	5.728	6.772	2.756	4.016
	[mm]	[203]	[140]	[130]	[100]	[7.938]	[70]	[34.925]	[103]	[13]	[110]	[248.5]	[103]	[145.5]	[172]	[70]	[102]
90	in	7.992	5.512	5.118	3.937	5/16"	2.756	1 3/8"	4.055	0.512	4.331	9.783	4.055	5.728	6.772	2.756	4.016
	[mm]	[203]	[140]	[130]	[100]	[7.938]	[70]	[34.925]	[103]	[13]	[110]	[248.5]	[103]	[145.5]	[172]	[70]	[102]

XN	I	K _c	K _f	M	M _u	P _p	R	Ru	S	t ₂	X										
40	in	1.575	-	5.287	M6x10	M5x10	1.437	2.953	1.669	0.236	0.837	0.059									
	[mm]	[40]											[134.3]	[21.26]	[1.5]						
50	in	1.969											-	M8x10	M6x10	1.713	3.346	2.114	0.276	1.114	0.059
	[mm]	[50]											[43.5]	[85]	[53.7]	[7]	[28.3]	[1.5]			
63	in	2.480											-	M8x14	M6x12	2.087	3.740	2.394	0.315	1.114	0.079
	[mm]	[63]											[53]	[95]	[60.8]	[8]	[28.3]	[2]			
75	in	2.953	-	M8x14	M8x12	2.244	4.528	2.783	0.394	1.367	0.079										
	[mm]	[75]	[57]	[115]	[70.7]	[10]	[34.72]	[2]													
89	in	3.543	-	M10x18	M8x14	2.638	5.118	2.783	0.472	1.518	0.079										
	[mm]	[90]	[67]	[130]	[70.7]	[12]	[38.56]	[2]													
90	in	3.543	-	M10x18	M8x14	2.638	5.118	2.783	0.472	1.518	0.079										
	[mm]	[90]	[67]	[130]	[70.7]	[12]	[38.56]	[2]													



2.7 Dimensions

2.7 Dimensiones

Output flange / Brida de salida

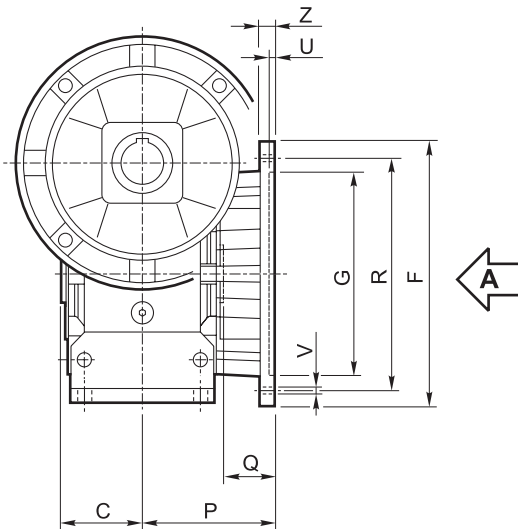

View from A / Vista de A

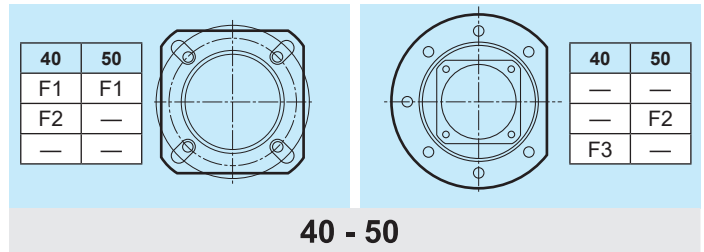

40 - 50

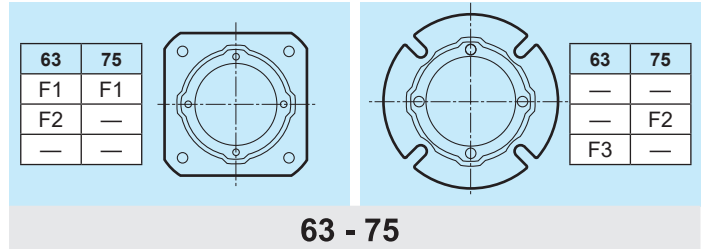

63 - 75

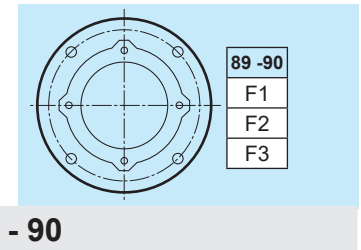

89 - 90

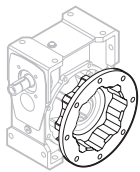

F...D
Standard

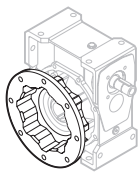

F...S

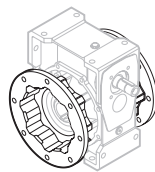

F...2

Type Tipo	C	F		G H8	P	Q	R	U	V			Z
											∅	
40	1.535 [39]		3.346 [85]	2.362 [60]	2.638 [67]	1.102 [28]	2.952 - 3.543 [75-90]	0.157 [4]	n° 4		0.354 [9]	0.315 [8]
			3.346 [85]	2.362 [60]	3.819 [97]	2.283 [58]	2.952 - 3.543 [75-90]	0.157 [4]	n° 4		0.354 [9]	0.315 [8]
			5.512 [140]		3.740 [95]	3.150 [80]	1.614 [41]	4.528 [115]	0.197 [5]		n° 7	0.354 [9]
50	1.811 [46]		3.701 [94]	2.756 [70]	3.543 [90]	1.732 [44]	3.346 - 3.937 [85-100]	0.197 [5]	n° 4		0.433 [11]	0.394 [10]
			6.299 [160]		4.331 [110]	3.504 [89]	1.693 [43]	5.118 [130]	0.197 [5]		n° 7	0.433 [11]
63	2.205 [56]		5.591 [142]	4.528 [115]	3.228 [82]	1.024 [26]	5.906 [150]	0.197 [5]	n° 4		0.433 [11]	0.433 [11]
			5.591 [142]	4.528 [115]	4.409 [112]	2.205 [56]	5.906 [150]	0.197 [5]	n° 4		0.433 [11]	0.433 [11]
			6.299 [160]		4.331 [110]	3.169 [80.5]	0.965 [24.5]	5.118 [130]	0.197 [5]	n° 4		0.433 [11]
75	2.362 [60]		6.299 [160]	5.118 [130]	4.370 [111]	2.008 [51]	6.496 [165]	0.197 [5]	n° 4		0.512 [13]	0.472 [12]
			6.299 [160]		4.331 [110]	3.543 [90]	1.181 [30]	5.118 [130]	0.236 [6]	n° 4		0.433 [11]
89 90	2.756 [70]		7.874 [200]	5.984 [152]	4.370 [111]	1.614 [41]	6.890 [175]	0.197 [5]	n° 4		0.512 [13]	0.472 [12]
			7.874 [200]	5.984 [152]	5.945 [151]	3.189 [81]	6.890 [175]	0.197 [5]	n° 4		0.512 [13]	0.512 [13]
			7.874 [200]	5.118 [130]	4.331 [110]	1.575 [40]	6.496 [165]	0.236 [6]	n° 4		0.433 [11]	0.433 [11]



2.7 Dimensions

2.7 Dimensiones

Input flange / Brida de entrada

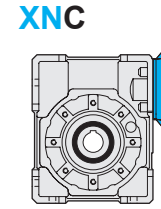
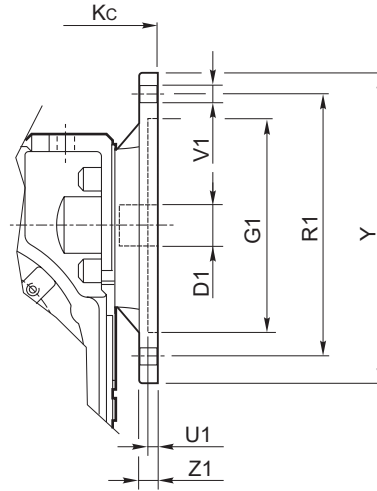
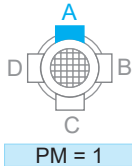

XNC	NEMA		G ₁	PM	R ₁	U ₁	V ₁		Y	Z ₁	K _c
				1			∅				
50	56 C	inch [mm]	4 1/2" [114.3]	•	5 7/8" [149.22]	0.236 [6]	0.394 [10]	4	6 1/2" [165.1]	0.472 [12]	3.583 [91]
	63	56 C 143 / 145 TC	inch [mm]	4 1/2" [114.3]	•	5 7/8" [149.22]	0.197 [5]	0.394 [10]	4	6 1/2" [165.1]	0.472 [12]
75	56 C	inch [mm]	4 1/2" [114.3]	•	5 7/8" [149.22]	0.197 [5]	0.394 [10]	4	6 1/2" [165.1]	0.433 [11]	4.409 [112]
	143 / 145 TC	inch [mm]	4 1/2" [114.3]	•	5 7/8" [149.22]	0.197 [5]	0.394 [10]	4	6 1/2" [165.1]	0.433 [11]	4.409 [112]
	182 / 184 TC	inch [mm]	8 1/2" [215.9]	•	7 1/4" [184.15]	0.216 [5.5]	0.551 [14]	4	9 [228.6]	0.650 [16.5]	4.547 [115.5]
89 90	56 C	inch [mm]	4 1/2" [114.3]	•	5 7/8" [149.22]	0.197 [5]	0.394 [10]	4	6 1/2" [165.1]	0.433 [11]	4.803 [122]
	143 / 145 TC	inch [mm]	4 1/2" [114.3]	•	5 7/8" [149.22]	0.197 [5]	0.394 [10]	4	6 1/2" [165.1]	0.433 [11]	4.803 [122]
	182 / 184 TC	inch [mm]	8 1/2" [215.9]	•	7 1/4" [184.15]	0.216 [5.5]	0.551 [14]	4	9 [228.6]	0.650 [16.5]	4.941 [125.5]

XNC	NEMA		D1 - Holes diameter NEMA / Diámetro orificios NEMA												
			5	7.5	10	15	20	25	30	40	50	65	80	100	
50	56 C	inch [mm]	5/8" [15.875]	5/8" [15.875]	5/8" [15.875]	5/8" [15.875]	5/8" [15.875]	5/8" [15.875]	5/8" [15.875]	5/8" [15.875]	5/8" [15.875]	5/8" [15.875]	5/8" [15.875]	5/8" [15.875]	/
	63	56 C 143 / 145 TC	inch [mm]	5/8" [15.875]	5/8" [15.875]	5/8" [15.875]	5/8" [15.875]	5/8" [15.875]	5/8" [15.875]	5/8" [15.875]	5/8" [15.875]	5/8" [15.875]	5/8" [15.875]	5/8" [15.875]	5/8" [15.875]
75	56 C	inch [mm]	/	/	/	/	/	/	5/8" [15.875]	5/8" [15.875]	5/8" [15.875]	5/8" [15.875]	5/8" [15.875]	5/8" [15.875]	5/8" [15.875]
	143 / 145 TC	inch [mm]	/	7/8" [22.225]	7/8" [22.225]	7/8" [22.225]	7/8" [22.225]	7/8" [22.225]	7/8" [22.225]	7/8" [22.225]	7/8" [22.225]	7/8" [22.225]	7/8" [22.225]	/	/
	182 / 184 TC	inch [mm]	/	1 1/8" [28.575]	1 1/8" [28.575]	1 1/8" [28.575]	1 1/8" [28.575]	/	/	/	/	/	/	/	/
89 90	56 C	inch [mm]	/	/	/	/	/	/	/	/	5/8" [15.875]	5/8" [15.875]	5/8" [15.875]	5/8" [15.875]	5/8" [15.875]
	143 / 145 TC	inch [mm]	/	/	/	/	/	/	/	7/8" [22.225]	7/8" [22.225]	7/8" [22.225]	7/8" [22.225]	7/8" [22.225]	/
	182 / 184 TC	inch [mm]	/	1 1/8" [28.575]	1 1/8" [28.575]	1 1/8" [28.575]	1 1/8" [28.575]	1 1/8" [28.575]	1 1/8" [28.575]	/	/	/	/	/	/

N.B.: STD mounting of P_M=1
N.B.: El montaje STD de P_M=1



2.7 Dimensions

2.7 Dimensiones

Input flange / Brida de entrada

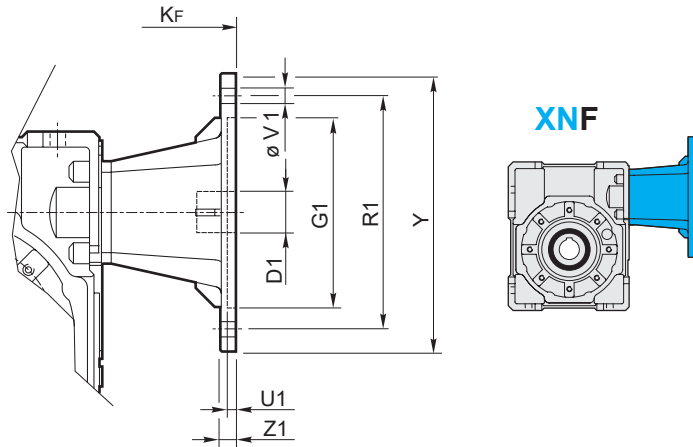
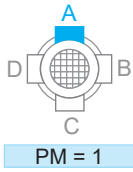

XNF	IEC		G ₁	PM	K _F	R ₁	U ₁	V ₁		Y	Z ₁	D1
				1				∅				
40	56 C	inch [mm]	4 1/2" [114.3]	•	5.287 [134.3]	5 7/8" [149.22]	0.197 [5]	0.394 [10]	4	6 1/2" [165.1]	0.472 [12]	5/8" [15.875]

N.B.: STD mounting of P_M=1
N.B.: El montaje STD de P_M=1



2.8 Accessories

2.8 Accesorios

Output shaft

Eje lento

To be produced on request

A producir bajo petición

Single output shaft
Eje lento standard

Double output shaft
Eje lento doble

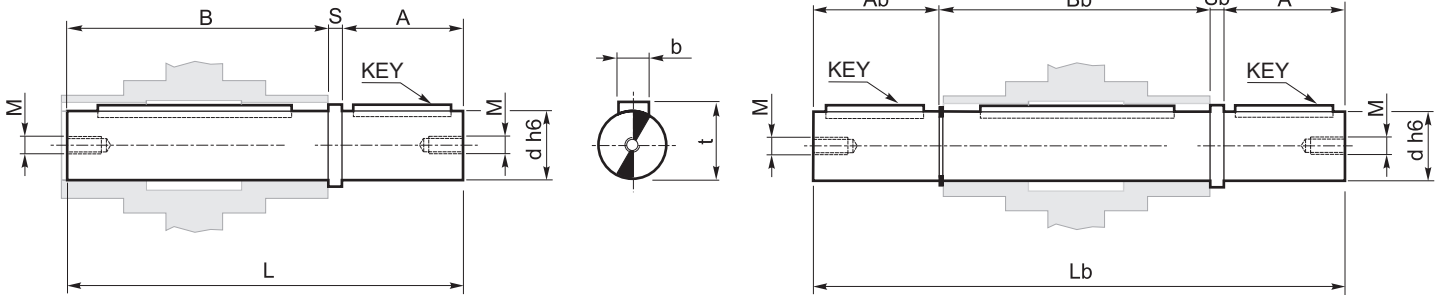

XN		A	B	b	d _{h6}	L	M	S	t	A	A _b	B _b	d _{h6}	L _b	S _b
40	inch	1.594	3.031	0.1875	3/4"	4.750	1/4" - 20	0.125	0.832	1.594	1.594	3.110	3/4"	6.423	0.125
	[mm]	[40.49]	[77]	[4.762]	[19.05]	[120.7]				[3.175]	[21.12]	[40.49]	[40.49]	[79.2]	[19.05]
50	inch	1.969	3.543	0.250	1"	5.653	3/8" - 16	0.14	1.109	1.969	1.969	3.661	1"	7.741	0.14
	[mm]	[50]	[90]	[6.35]	[25.4]	[143.6]				[3.59]	[28.17]	[50]	[50]	[93.2]	[25.4]
63	inch	1.969	4.370	0.250	1"	6.510	3/8" - 16	0.172	1.109	1.969	1.969	4.449	1"	8.558	0.171
	[mm]	[50]	[111]	[6.35]	[25.4]	[165.4]				[4.36]	[28.17]	[50]	[50.0]	[113.2]	[25.4]
75	inch	1.969	4.370	0.250	1 1/4"	6.510	3/8" - 16	0.140	1.362	—					
	[mm]	[50]	[111]	[6.35]	[31.75]	[165.4]				[3.55]	[34.59]				
75	inch	2.375	4.685	0.250	1 1/4"	7.225	1/2" - 13	0.165	1.362	2.375	2.375	4.764	1 1/4"	9.679	0.165
	[mm]	[60.33]	[119]	[6.35]	[31.75]	[183.5]				[4.19]	[34.54]	[60.325]	[60.325]	[121.5]	[31.75]
89 90	inch	3.156	5.472	0.3125	1 3/8"	8.831	1/2" - 13	0.203	1.5135	3.156	3.156	5.571	1 3/8"	12.086	0.203
	[mm]	[80.16]	[139]	[7.938]	[34.925]	[224.3]				[5.16]	[38.443]	[80.16]	[80.16]	[141.5]	[34.925]



Torque arm

Brazo de reacción

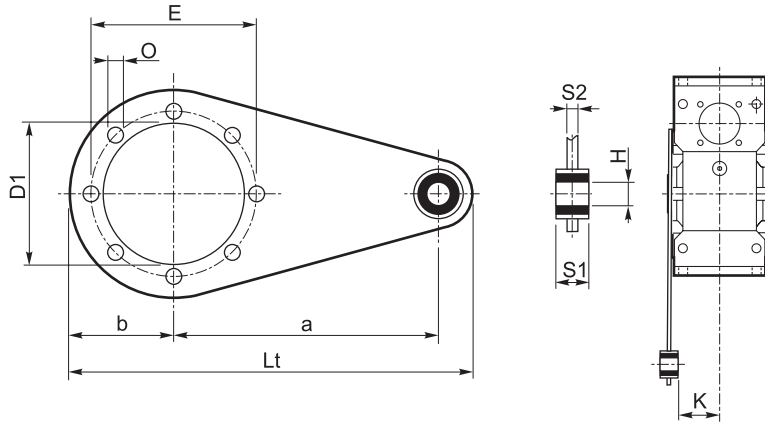

XN		a	b	D ₁	E	H	K	L _t	O	S1	S2
40	in	3.937	1.772	2.362	2.953	0.394	1.240	6.575	0.276	0.551	0.157
	[mm]	[100]	[45]	[60]	[75]	[10]	[31.5]	[167]	[7]	[14]	[4]
50	in	3.937	1.969	2.756	3.346	0.394	1.535	6.772	0.354	0.551	0.197
	[mm]	[100]	[50]	[70]	[85]	[10]	[39]	[172]	[9]	[14]	[5]
63	in	5.906	2.165	3.150	3.740	0.394	1.929	8.937	0.354	0.551	0.236
	[mm]	[150]	[55]	[80]	[95]	[10]	[49]	[227]	[9]	[14]	[6]
75	in	7.874	2.756	3.740	4.528	0.787	1.870	11.890	0.354	0.984	0.236
	[mm]	[200]	[70]	[95]	[115]	[20]	[47.5]	[302]	[9]	[25]	[6]
89 - 90	in	7.874	3.150	4.331	5.118	0.787	2.264	12.283	0.433	0.984	0.236
	[mm]	[200]	[80]	[110]	[130]	[20]	[57.5]	[312]	[11]	[25]	[6]

Protection Kit:

Kit de protección:

Output bore / Eje hueco

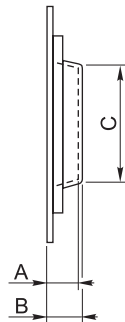

XN		A	B	C
40	in	0.551	0.610	1.752
	[mm]	[14]	[15.5]	[44.5]
50	in	0.591	0.650	2.126
	[mm]	[15]	[16.5]	[54]
63	in	0.669	0.748	2.362
	[mm]	[17]	[19]	[60]
75	in	0.689	0.787	2.756
	[mm]	[17.5]	[20]	[70]
89 - 90	in	0.846	0.945	3.150
	[mm]	[21.5]	[24]	[80]

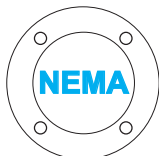

C	Worm gear reducers KN	<i>Reductores sinfin corona</i> KN	C1
----------	---------------------------------	--	-----------

INDEX	INDICE	
3.1 Characteristics	<i>Características</i>	C2
3.2 Designation	<i>Nomenclatura</i>	C3
3.3 Lubrication	<i>Lubricación</i>	C4
3.4 Terminal board position	<i>Posición de la caja de bornes</i>	C5
3.5 Radial load	<i>Cargas radiales</i>	C6
3.6 Technical data	<i>Datos técnicos</i>	C8
3.7 Dimensions	<i>Dimensiones</i>	C10
3.8 Accessories	<i>Accesorios</i>	C14

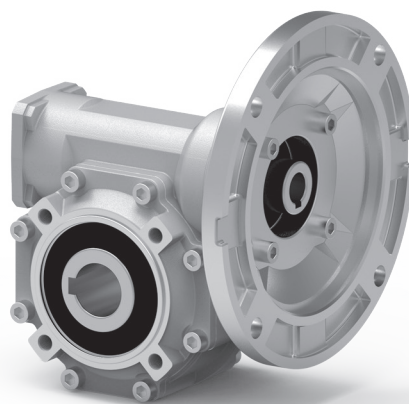



Worm gear reducers

KN

3.1 Characteristics

- The KN worm gear reducers are extremely light thanks to the compact shape of the housing, which is in cast iron for size 90, in die-cast aluminium for sizes 50, 63, 75 and 89.
- This series features a wide range of versions, with and without feet, which makes it extremely versatile for utilization in various applications.
- The KN series is available for motor mounting version (PAM) only and not with the male input shaft.
- The worm shaft is in case-and quenchhardened alloy steel and ground.
- The worm wheel has a cast-iron hub with inserted cast bronze ring.
- The cast-iron housings are painted BLUE RAL5010 whereas the aluminium housings are sandblasted.
- The hollow output shaft is supplied as standard. A broad range of accessories is available: tapered roller bearings on the worm wheel, output flange, single or double-extended output shaft, torque arm, output bore protection kit.

Reductores sin fin corona

KN

3.1 Características

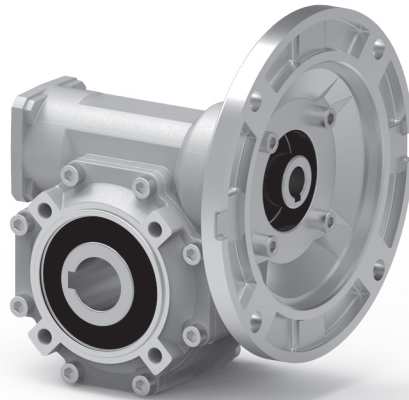

- Los reductores de la serie KN se presentan formidablemente ligeros gracias a su forma compacta de la carcasa en hierro fundido en los tamaño 90 y en aluminio fundido bajo presión para los tamaños 50, 63, 75 y 89.
- La serie presenta varias posibilidades de versiones, con y sin pié, que la hacen aún más adaptable en el uso de cada tipología de aplicación.
- La serie KN disponible exclusivamente en las versiones con disposición de enganche motor (PAM) y no con eje con entrada macho.
- Los tornillos sin fin son de acero aleado cementado – templado y son rectificadas.
- Los dientes de los engranajes realizados en hierro fundido y el anillo en bronce.
- Las carcasas en hierro fundido pintadas de AZUL RAL 5010 mientras que las de aluminio pulidas a chorro de arena.
- *Está incluido el eje de salida hueco de serie, con una amplia disponibilidad de accesorios: cojinetes de bolas sobre el engranaje, brida de salida, eje lento con 1 y dos salidas, brazo de reacción, kit de protección eje hueco.*





3.2 Designation

3.2 Nomenclatura

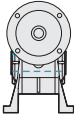
Gear reducer Reductores	Input type Tipo entrada	Size Tamaño	Version Versión	Ratio Relación redu.	Motor coupling Enganche motor.	Mounting position Posición montaje	Hollow output shaft Eje hueco de salida
KN	C	50	F1S	10	NEMA	B3	H25.4
Worm gear reducer Reductores de sinfín corona	 C	50 63 75 89  Aluminium Aluminio 90  Cast iron Hierro fundido	A1-A2 B1-B2 V1-V2 P F1S-F2S F3S F1D-F2D F3D	5 7.5 10 15 20 25 30 40 50 65 80 100	56C 143 TC 145 TC 182 TC 184 TC	B3 B6 B7 B8 V5 V6	see tables ver tablas 

Versions

Versión

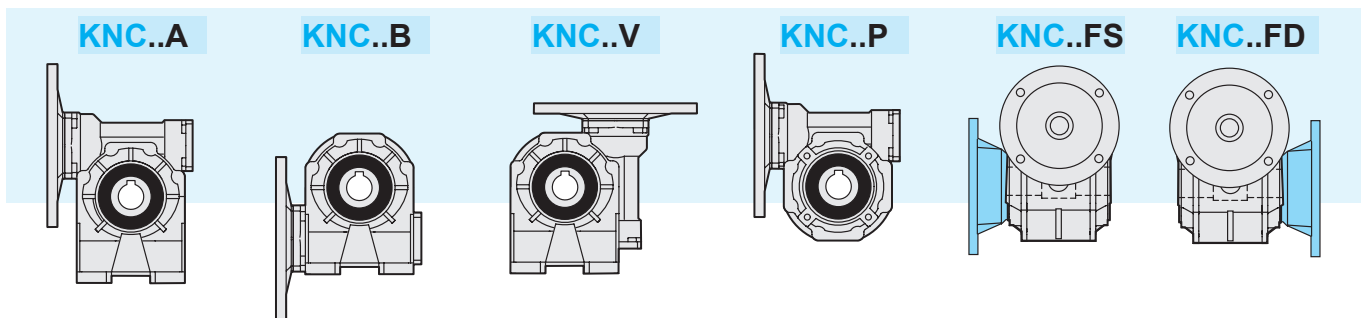



3.3 Lubrication

KN series worm gear reducers are supplied with synthetic lubricant, PAG base, viscosity index ISO VG320. Mounting position always to be specified when ordering.

For more details, see page A5, paragraph 1.7.

3.3 Lubricación

Los reductores de la serie KN se entregan completos de lubricante sintético a base PAG con viscosidad ISO VG320. Se ruega precisar la posición de montaje deseada a la hora de realizar el pedido.

Para más detalles ver página A5 párrafo 1.7

Mounting positions

Posición de montaje

F,P

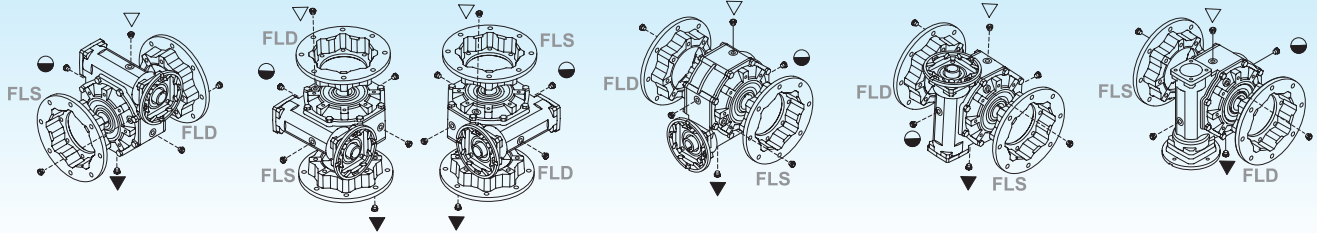

A

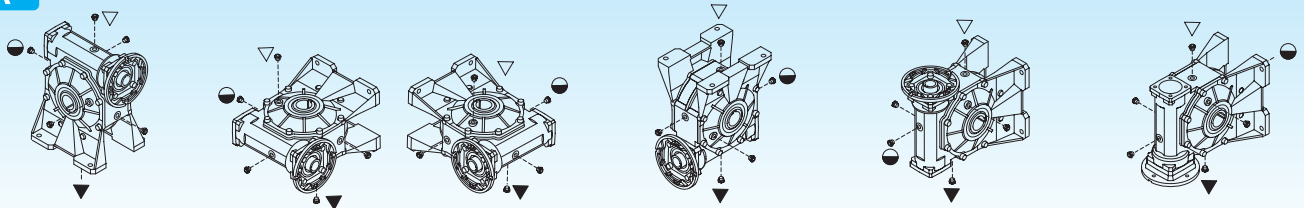

V

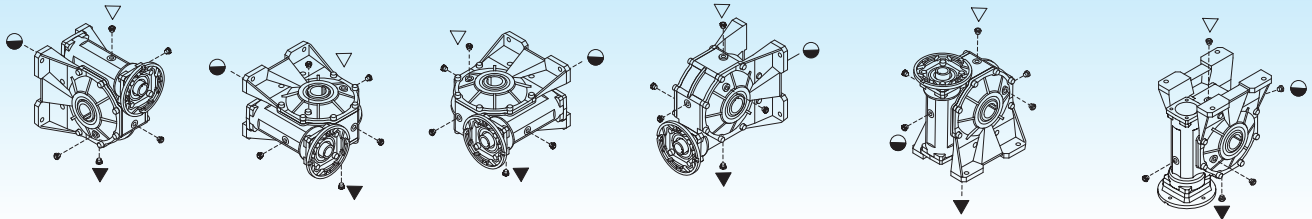

B

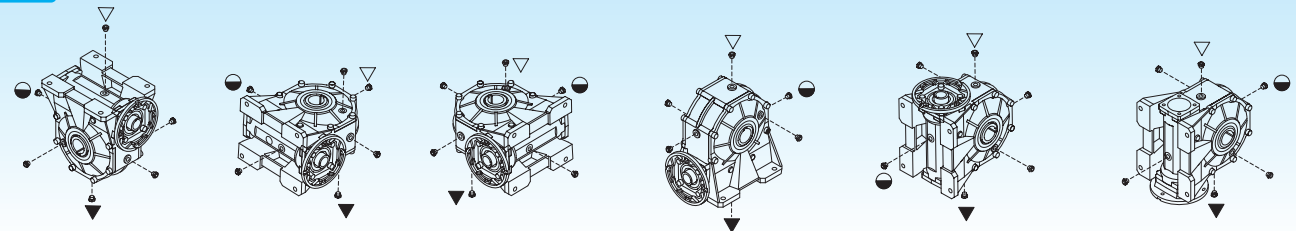

B3

B6

B7

B8

V5

V6

▽ Filling and breather / Carga y respiradero

● Level / Nivel

▼ Drain / Descarga

30, 40, 50, 63, 75 and 89 aluminium housings have one oil filling plug only.

Los cuerpos de aluminio 30, 40, 50, 63, 75 tiene solamente un tapón de llenado para aceite.



gal [lt]		Oil quantity / Cant. de aceite			
		Mounting position / Posición de montaje			
		B3	B6 - B7	B8	V5 - V6
KNC	50	0.021 [0.08]	0.032 [0.12]	0.021 [0.08]	
	63	0.042 [0.16]	0.058 [0.22]	0.042 [0.16]	
	75	0.069 [0.26]	0.090 [0.34]	0.069 [0.26]	
	89	0.158 [0.60]	0.185 [0.70]	0.158 [0.60]	
	90	0.264 [1.0]	0.211 [0.80]	0.211 [0.80]	0.343 [1.3]

3.4 Terminal board position

3.4 Posición borne

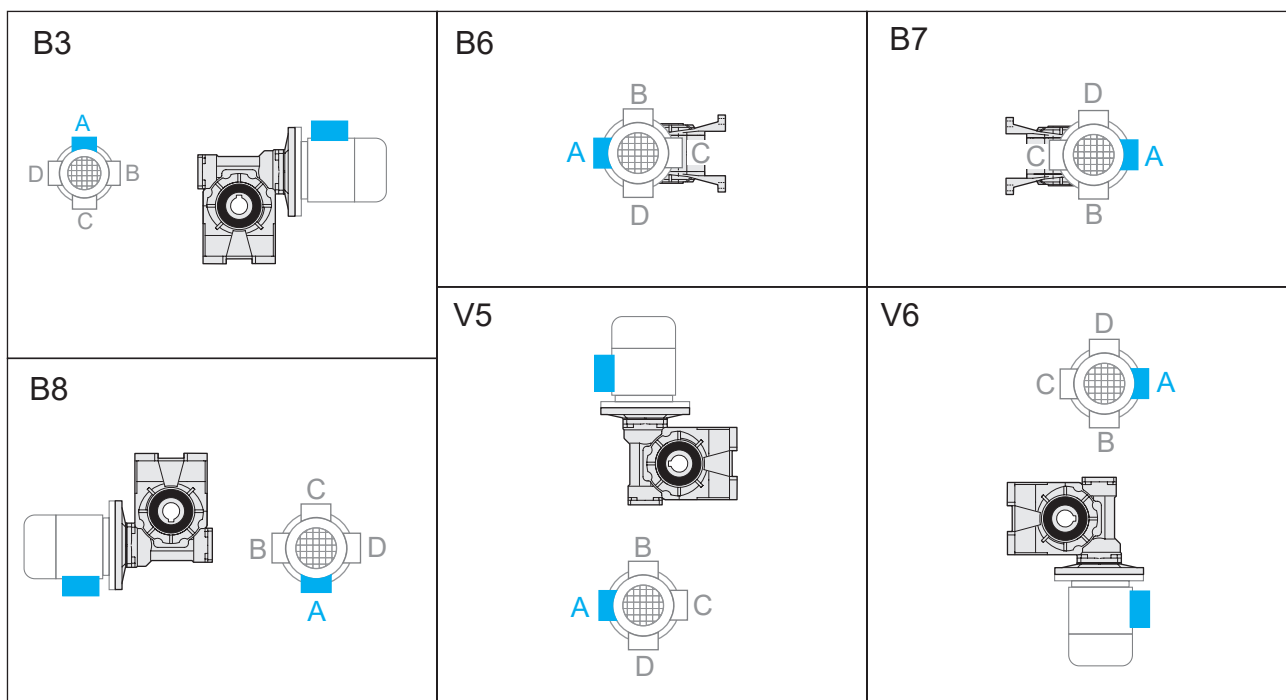

Mounting position always to be specified when ordering.
Terminal board position see page C13 (PM=1).

*A la hora de realizar el pedido se ruega precisar la posición de montaje y la posición de la caja de bornes.
Posición borne v. pág. C13 (PM=1)*



3.5 Radial load

Any transmission device coupled to the output shaft generates radial loads Fr_2 .

The load values reported in the table, depending on input and output speed, are to be considered as acting at the half-way point of the projection; if the load is applied at 1/3 of the projection, increase the values in the table by 25%; if the load is applied at 2/3, reduce the values by 25%.

Axial loads applicable at output F_{a2} are reported in the tables.

With regard to double projecting shafts, each end can sustain a radial load which equals 3/5 of the values listed in the table, on condition that they act in the same direction and have the same intensity.

3.5 Cargas radiales

Cada clase de órgano de transmisión que es conectado al eje de salida determina cargas radiales Fr_2 .

Los valores señalados en la tabla en función a las varias velocidades de entrada y salida se suponen aplicándolas en la mitad del eje como fuerzas agentes a esto; para una ubicación de 1/3 de la longitud se aumentará hasta un 25% los valores de la tabla, mientras para una posición de 2/3 de la longitud se disminuirá los mismos valores a un 25%.

Los valores de las cargas axiales aplicables en salida F_{a2} están señalados en las tablas.

En los ejes con salida doble, cada extremidad puede soportar una carga radial igual a 3/5 del valor de la tabla, siempre y cuando las cargas aplicables sean de igual intensidad y reaccionen en el mismo sentido.

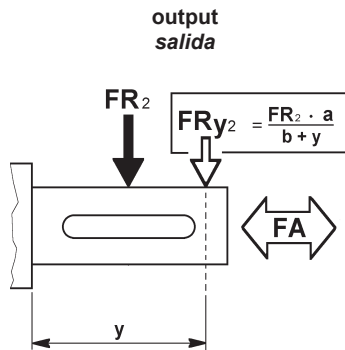



3.5 Radial load

3.5 Cargas radiales

RADIAL BALL BEARINGS / RODAMIENTOS RADIALES												
$n_1=1750$ rpm		50		63		75		89		90		
i_n	n_2 [rpm]	a	b	a	b	a	b	a	b	a	b	
		inch										
		[mm]										
		Fr_2	Fa_2	Fr_2	Fa_2	Fr_2	Fa_2	Fr_2	Fa_2	Fr_2	Fa_2	
5	350	lbf [N]	777 [1400]	166 [300]	999 [1800]	200 [360]	/		/		/	
7.5	233	lbf [N]	915 [1650]	183 [330]	1165 [2100]	233 [420]	1387 [2500]	277 [500]	1442 [2600]	288 [520]	1442 [2600]	288 [520]
10	175	lbf [N]	999 [1800]	200 [360]	1276 [2300]	255 [460]	1553 [2800]	311 [560]	1664 [3000]	333 [600]	1664 [3000]	333 [600]
15	117	lbf [N]	1082 [1950]	216 [390]	1442 [2600]	288 [520]	1664 [3000]	333 [600]	1886 [3400]	377 [680]	1886 [3400]	377 [680]
20	87.5	lbf [N]	1221 [2200]	244 [440]	1553 [2800]	311 [560]	1831 [3300]	366 [660]	2108 [3800]	422 [760]	2108 [3800]	422 [760]
25	70	lbf [N]	1332 [2400]	266 [480]	1720 [3100]	344 [620]	2053 [3700]	411 [740]	2275 [4100]	455 [820]	2275 [4100]	455 [820]
30	58	lbf [N]	1442 [2600]	288 [520]	1886 [3400]	377 [680]	2219 [4000]	444 [800]	2497 [4500]	499 [900]	2497 [4500]	499 [900]
40	44	lbf [N]	1581 [2850]	316 [570]	2053 [3700]	411 [740]	2441 [4400]	488 [880]	2719 [4900]	544 [980]	2719 [4900]	544 [980]
50	35	lbf [N]	1720 [3100]	344 [620]	2219 [4000]	444 [800]	2691 [4850]	538 [970]	2940 [5300]	588 [1060]	2940 [5300]	588 [1060]
60	29	lbf [N]	1775 [3200]	355 [640]	2330 [4200]	466 [840]	2774 [5000]	555 [1000]	3107 [5600]	621 [1120]	3107 [5600]	621 [1120]
63	28	lbf [N]	1886 [3400]	377 [680]	2469 [4450]	494 [890]	2940 [5300]	588 [1060]	3273 [5900]	655 [1180]	3273 [5900]	655 [1180]
80	22	lbf [N]	2108 [3800]	422 [760]	2719 [4900]	544 [980]	3218 [5800]	644 [1160]	3606 [6500]	721 [1300]	3606 [6500]	721 [1300]
100	17.5	lbf [N]	2219 [4000]	444 [800]	2996 [5400]	599 [1080]	3606 [6500]	721 [1300]	3884 [7000]	777 [1400]	3884 [7000]	777 [1400]
120	15	lbf [N]	2275 [4100]	455 [820]	3051 [5500]	610 [1100]	3634 [6550]	727 [1310]	3939 [7100]	788 [1420]	3939 [7100]	788 [1420]
150	12	lbf [N]	2358 [4250]	472 [850]	3107 [5600]	621 [1120]	3662 [6600]	732 [1320]	4050 [7300]	810 [1460]	4050 [7300]	810 [1460]
160	11	lbf [N]	2386 [4300]	477 [860]	3162 [5700]	632 [1140]	3717 [6700]	743 [1340]	4106 [7400]	821 [1480]	4106 [7400]	821 [1480]
≥ 200	≤ 9	lbf [N]	2497 [4500]	499 [900]	3329 [6000]	666 [1200]	3939 [7100]	788 [1420]	4383 [7900]	877 [1580]	4383 [7900]	877 [1580]



3.6 Technical data

3.6 Datos técnicos

50	$n_1 = 1750$				KNC						
	i_n	n_2 [min ⁻¹]	Rd	P_{10} [Hp]	T_2		P_1		FS'	NEMA	
					[Ft·lb]	[Nm]	[Hp]	[kW]			
 7.5	5	350	0.87	1.6	10	13	0.75	0.55	4.8	56 C	
	7.5	233	0.86	1.6	14	19	0.75	0.55	3.7		
	10	175	0.84	1.3	18	25	0.75	0.55	2.9		
	15	117	0.80	1.1	27	36	0.75	0.55	2.1		
	20	88	0.78	0.9	35	47	0.75	0.55	1.6		
	25	70	0.74	0.8	27	37	0.50	0.37	1.8		
	30	58	0.71	0.8	32	43	0.50	0.37	1.5		
	40	44	0.67	0.7	40	54	0.50	0.37	1.3		
	50	35	0.62	0.5	31	42	0.33	0.25	1.7		
	65	27	0.58	0.5	38	51	0.33	0.25	1.3		
80	22	0.54	0.5	31	42	0.25	0.18	1.4			

63	$n_1 = 1750$				KNC							
	i_n	n_2 [min ⁻¹]	Rd	P_{10} [Hp]	T_2		P_1		FS'	NEMA		
					[Ft·lb]	[Nm]	[Hp]	[kW]				
 12.6	5	350	0.88	2.4	27	36	2.0	1.5	3.1	56 C	143 TC	145 TC
	7.5	233	0.87	2.4	39	53	2.0	1.5	2.3			
	10	175	0.85	2.1	51	70	2.0	1.5	1.8			
	15	117	0.81	1.6	73	99	2.0	1.5	1.3			
	20	88	0.80	1.6	70	96	1.5	1.1	1.5			
	25	70	0.77	1.3	58	79	1.0	0.75	1.5			
	30	58	0.73	1.2	67	90	1.0	0.75	1.6			
	40	44	0.69	1.1	83	112	1.0	0.75	1.3			
	50	35	0.65	0.9	72	98	0.75	0.55	1.2			
	65	27	0.61	0.8	59	80	0.50	0.37	1.5			
	80	22	0.58	0.8	46	63	0.33	0.25	1.8			
	100	18	0.53	0.7	52	70	0.33	0.25	1.5			

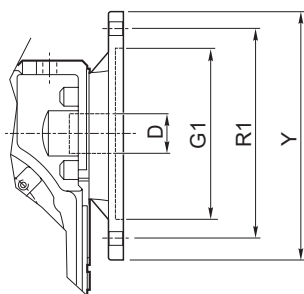

		NEMA	
		56C	143TC - 145TC
G1	in [mm]	4 1/2" [114.3]	
R1	in [mm]	5 7/8" [149.22]	
Y	in [mm]	6.5 [165.10]	
D	in [mm]	0.625 [15.875]	0.875 [22.225]

* **WARNING:** Maximum allowable torque $[T_{2M}]$ must be calculated using the following service factor : $T_{2M} = T_2 \times FS'$

* **ATENCION:** el par máximo utilizable $[T_{2M}]$ deberá calcularse con respecto al factor de servicio : $T_{2M} = T_2 \times FS'$



3.6 Technical data

3.6 Datos técnicos

75	$n_1 = 1750$				KNC									
	i_n	n_2 [min ⁻¹]	Rd	P_{10} [Hp]	T_2		P_1		FS'	NEMA				
					[Ft·lb]	[Nm]	[Hp]	[kW]		143 TC		145 TC		182 TC
17.6 	7.5	233	0.87	3.4	94	128	5.0	3.6	1.4	56 C	143 TC	145 TC	182 TC	184 TC
	10	175	0.86	3.1	76	103	3.0	2.2	1.9					
	15	117	0.83	2.5	110	149	3.0	2.2	1.4					
	20	88	0.81	2.3	97	132	2.0	1.5	1.7					
	25	70	0.78	2.0	118	160	2.0	1.5	1.3					
	30	58	0.74	1.6	99	134	1.5	1.1	1.6					
	40	44	0.71	1.5	125	170	1.5	1.1	1.4					
	50	35	0.67	1.3	101	137	1.0	0.75	1.5					
	65	27	0.63	1.2	91	123	0.75	0.55	1.6					
	80	22	0.60	1.1	106	143	0.75	0.55	1.3					
100	18	0.56	0.9	120	163	0.75	0.55	1.0	—	—	—	—		

89	$n_1 = 1750$				KNC									
	i_n	n_2 [min ⁻¹]	Rd	P_{10} [Hp]	T_2		P_1		FS'	NEMA				
					[Ft·lb]	[Nm]	[Hp]	[kW]		143 TC		145 TC		182 TC
25.4 	7.5	233	0.88	4.0	96	130	5.0	3.6	2.2	56 C	143 TC	145 TC	182 TC	184 TC
	10	175	0.86	3.4	125	169	5.0	3.6	1.8					
	15	117	0.84	3.0	111	151	3.0	2.2	2.1					
	20	88	0.82	2.7	145	196	3.0	2.2	1.8					
	25	70	0.80	2.4	177	240	3.0	2.2	1.4					
	30	58	0.76	2.0	203	275	3.0	2.2	1.3					
	40	44	0.72	1.7	173	234	2.0	1.5	1.6					
	50	35	0.69	1.5	208	282	2.0	1.5	1.3					
	65	27	0.65	1.3	187	253	1.5	1.1	1.3					
	80	22	0.63	1.3	151	205	1.0	0.75	1.5					
100	18	0.58	1.1	125	169	0.75	0.55	1.6	—	—	—	—		

90	$n_1 = 1750$				KNC									
	i_n	n_2 [min ⁻¹]	Rd	P_{10} [Hp]	T_2		P_1		FS'	NEMA				
					[Ft·lb]	[Nm]	[Hp]	[kW]		143 TC		145 TC		182 TC
36.2 	7.5	233	0.88	4.0	96	130	5.0	3.6	2.2	56 C	143 TC	145 TC	182 TC	184 TC
	10	175	0.86	3.4	125	169	5.0	3.6	1.8					
	15	117	0.84	3.0	111	151	3.0	2.2	2.1					
	20	88	0.82	2.7	145	196	3.0	2.2	1.8					
	25	70	0.80	2.4	177	240	3.0	2.2	1.4					
	30	58	0.76	2.0	203	275	3.0	2.2	1.3					
	40	44	0.72	1.7	173	234	2.0	1.5	1.6					
	50	35	0.69	1.5	208	282	2.0	1.5	1.3					
	65	27	0.65	1.3	187	253	1.5	1.1	1.3					
	80	22	0.63	1.3	151	205	1.0	0.75	1.5					
100	18	0.58	1.1	125	169	0.75	0.55	1.6	—	—	—	—		

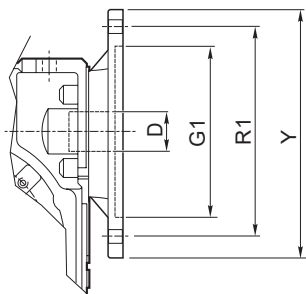

		NEMA		
		56C	143TC - 145TC	182TC - 184 TC
G1	in [mm]	4 1/2" [114.3]		8.5 [215.9]
R1	in [mm]	5 7/8" [149.22]		7.25 [184.15]
Y	in [mm]	6.5 [165.10]		9 [228.6]
D	in [mm]	0.625 [15.875]	0.875 [22.225]	1.125 [28.575]

* **WARNING:** Maximum allowable torque [T_{2M}] must be calculated using the following service factor : $T_{2M} = T_2 \times FS'$

* **ATENCIÓN:** el par máximo utilizable [T_{2M}] deberá calcularse con respecto al factor de servicio: $T_{2M} = T_2 \times FS'$



3.7 Dimensions

3.7 Dimensiones

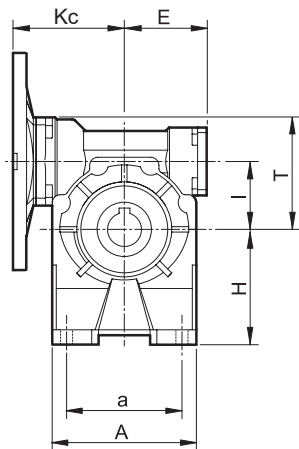
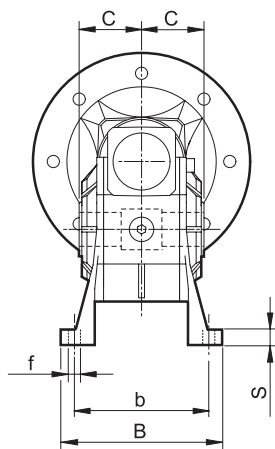

KNC..A

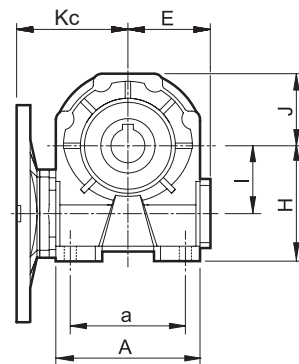
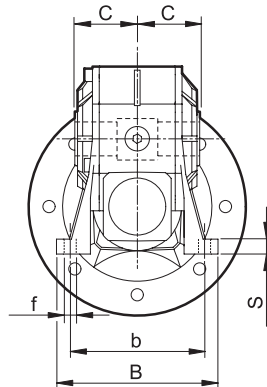

KNC..B

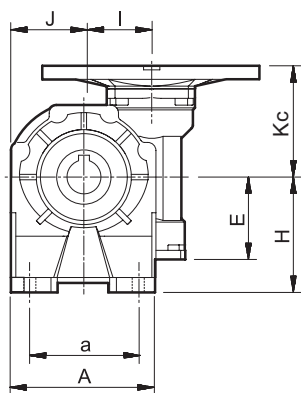
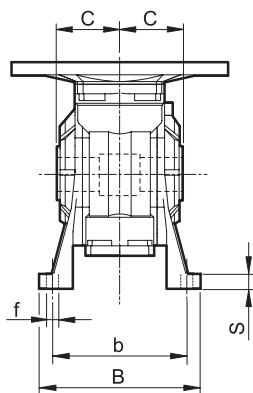

KNC..V

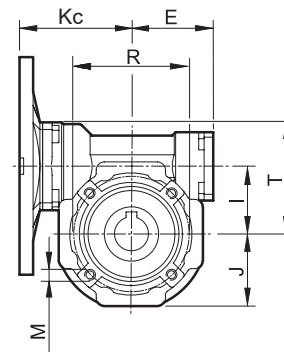
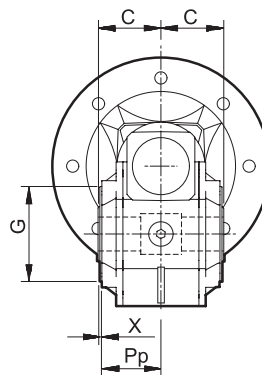

KNC..P

Shaft-mounted flange / Brida pendular

50

63 - 75 - 89 - 90

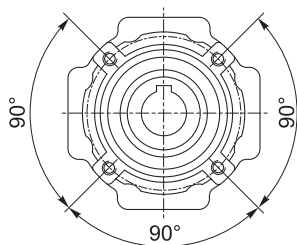

4 Holes / Agujeros

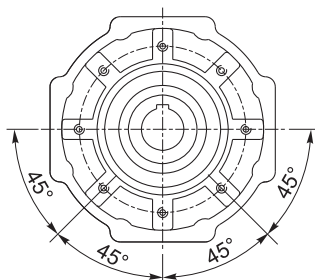

8 Holes / Agujeros

Output hollow shaft
Eje hueco de salida

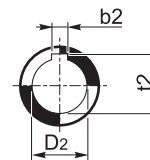



3.7 Dimensions

3.7 Dimensiones

		50	63	75	89 - 90
b2	in [mm]	1/4" [6.35]	1/4" [6.35]	1/4" [6.35]	5/16" [7.938]
C	in [mm]	1.811 [46]	2.205 [56]	2.362 [60]	2.756 [70]
D2 H8	in [mm]	1" [25.4]	1" [25.4]	1 1/4" [31.75]	1 3/8" [34.925]
E	in [mm]	2.362 [60]	2.795 [71]	3.346 [85]	4.055 [103]
G h8	in [mm]	2.756 [70]	3.150 [80]	3.740 [95]	4.331 [110]
I	in [mm]	1.969 [50]	2.480 [63]	2.953 [75]	3.543 [90]
J	in [mm]	2.106 [53.5]	2.520 [64]	3.071 [78]	3.937 [100]
M	in [mm]	M8x10	M8x14	M8x14	M10x18
Pp	in [mm]	1.713 [43.5]	2.087 [53]	2.244 [57]	2.638 [67]
R	in [mm]	3.346 [85]	3.740 [95]	4.528 [115]	5.118 [130]
T	in [mm]	3.248 [82.5]	3.957 [100.5]	4.587 [116.5]	5.177 [131.5]
t2	in [mm]	1.114 [28.3]	1.114 [28.3]	1.367 [34.72]	1.518 [38.56]
X	in [mm]	0.059 [1.5]	0.079 [2]	0.079 [2]	0.079 [2]

		Feet Pié	50	63	75	89 - 90
A	in [mm]	1	4.173 [106]	5.020 [127.5]	6.122 [155.5]	7.480 [190]
	in [mm]	2	4.173 [106]			7.480 [190]
a	in [mm]	1	2.480 - 3.346 [63-85]	3.740 [95]	4.724 [120]	5.512 [140]
	in [mm]	2	2.480 - 3.346 [63-85]			5.512 [140]
B	in [mm]	1	4.685 [119]	5.354 [136]	5.512 [140]	6.614 [168]
	in [mm]	2	4.685 [119]			6.614 [168]
b	in [mm]	1	3.898 [99]	4.370 [111]	4.528 [115]	5.512 [140]
	in [mm]	2	3.898 [99]			5.748 [146]
f	in [mm]	1	0.354 [9]	0.433 [11]	0.433 [11]	0.512 [13]
	in [mm]	2	0.354 [9]			0.433 [11]
H	in [mm]	1	3.346 [85]	3.937 [100]	4.528 [115]	5.315 [135]
	in [mm]	2	3.228 [82]			5.591 [142]
S	in [mm]	1	0.433 [11]	0.472 [12]	0.472 [12]	0.551 [14]
	in [mm]	2	0.315 [8]			0.551 [14]



3.7 Dimensions

3.7 Dimensiones

Output flange / Brida de salida

View from A / Vista de A

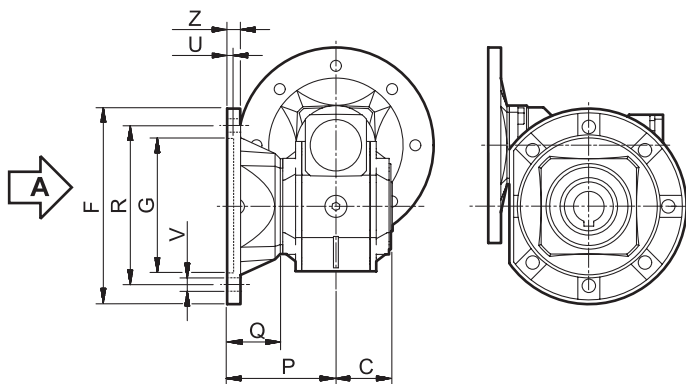

KNC..F

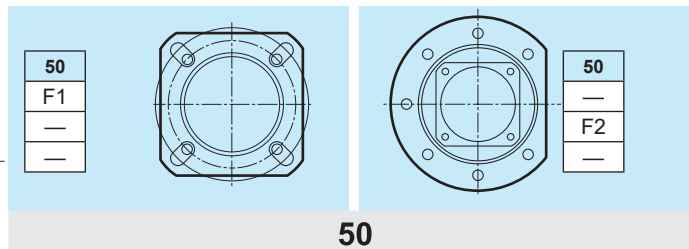

50

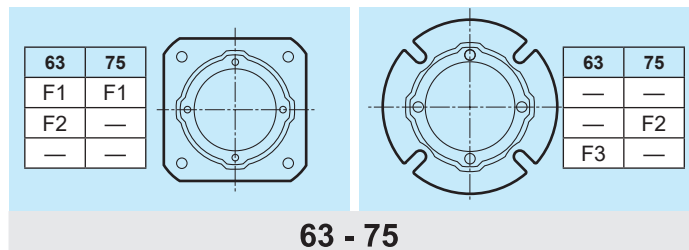

63 - 75

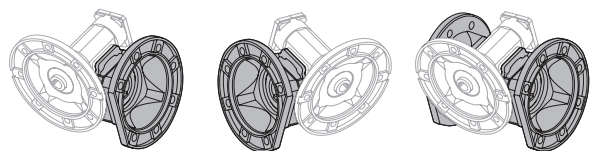

F...D
Standard

F...S

F...2

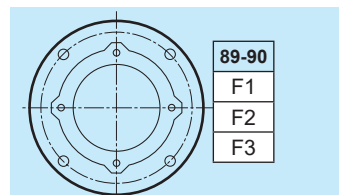

89 - 90

Type Tipo	C	F		G H8	P	Q	R	U	V			Z
											\emptyset	
50	F1	1.811		3.701 [94]	2.756 [70]	3.543 [90]	1.732 [44]	3.346 - 3.937 [85-100]	0.197 [5]	n° 4	0.433 [11]	0.394 [10]
	F2	[46]	6.299 [160]		4.331 [110]	3.504 [89]	1.693 [43]	5.118 [130]	0.197 [5]	n° 7	0.433 [11]	0.433 [11]
63	F1	2.205 [56]		5.591 [142]	4.528 [115]	3.228 [82]	1.024 [26]	5.906 [150]	0.197 [5]	n° 4	0.433 [11]	0.433 [11]
	F2			5.591 [142]	4.528 [115]	4.409 [112]	2.205 [56]	5.906 [150]	0.197 [5]	n° 4	0.433 [11]	0.433 [11]
	F3		6.299 [160]		4.331 [110]	3.169 [80.5]	0.965 [24.5]	5.118 [130]	0.197 [5]	n° 4	0.433 [11]	0.472 [12]
75	F1	2.362 [60]		6.299 [160]	5.118 [130]	4.370 [111]	2.008 [51]	6.496 [165]	0.197 [5]	n° 4	0.512 [13]	0.472 [12]
	F2		6.299 [160]		4.331 [110]	3.543 [90]	1.181 [30]	5.118 [130]	0.236 [6]	n° 4	0.433 [11]	0.512 [13]
89 90	F1	2.756 [70]		7.874 [200]	5.984 [152]	4.370 [111]	1.614 [41]	6.890 [175]	0.197 [5]	n° 4	0.512 [13]	0.472 [12]
	F2		7.874 [200]		5.984 [152]	5.945 [151]	3.189 [81]	6.890 [175]	0.197 [5]	n° 4	0.512 [13]	0.512 [13]
	F3		7.874 [200]		5.118 [130]	4.331 [110]	1.575 [40]	6.496 [165]	0.236 [6]	n° 4	0.433 [11]	0.433 [11]



3.7 Dimensions

3.7 Dimensiones

Input flange / Brida de entrada

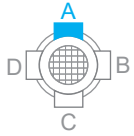

PM = 1

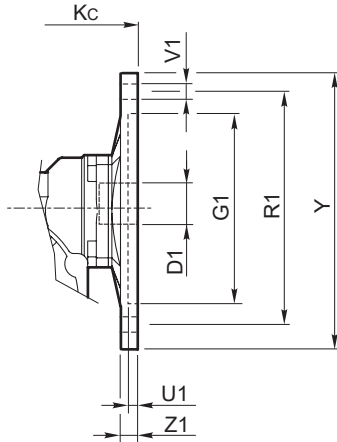

KNC	NEMA		G ₁	PM 1	R ₁	U ₁	V ₁		Y	Z ₁	K _c
							∅				
50	56 C	inch [mm]	4 1/2" [114.3]	•	5 7/8" [149.22]	0.236 [6]	0.394 [10]	4	6 1/2" [165.1]	0.472 [12]	3.583 [91]
	143 / 145 TC	inch [mm]	4 1/2" [114.3]	•	5 7/8" [149.22]	0.197 [5]	0.394 [10]	4	6 1/2" [165.1]	0.472 [12]	3.819 [97]
75	56 C	inch [mm]	4 1/2" [114.3]	•	5 7/8" [149.22]	0.197 [5]	0.394 [10]	4	6 1/2" [165.1]	0.433 [11]	4.409 [112]
	143 / 145 TC	inch [mm]	4 1/2" [114.3]	•	5 7/8" [149.22]	0.197 [5]	0.394 [10]	4	6 1/2" [165.1]	0.433 [11]	4.409 [112]
	182 / 184 TC	inch [mm]	8 1/2" [215.9]	•	7 1/4" [184.15]	0.216 [5.5]	0.551 [14]	4	9 [228.6]	0.650 [16.5]	4.547 [115.5]
89 90	56 C	inch [mm]	4 1/2" [114.3]	•	5 7/8" [149.22]	0.197 [5]	0.394 [10]	4	6 1/2" [165.1]	0.433 [11]	4.803 [122]
	143 / 145 TC	inch [mm]	4 1/2" [114.3]	•	5 7/8" [149.22]	0.197 [5]	0.394 [10]	4	6 1/2" [165.1]	0.433 [11]	4.803 [122]
	182 / 184 TC	inch [mm]	8 1/2" [215.9]	•	7 1/4" [184.15]	0.216 [5.5]	0.551 [14]	4	9 [228.6]	0.650 [16.5]	4.941 [125.5]

KNC	NEMA		D1 - Holes diameter NEMA / Diámetro orificios NEMA												
			5	7.5	10	15	20	25	30	40	50	65	80	100	
50	56 C	inch [mm]	5/8" [15.875]	5/8" [15.875]	5/8" [15.875]	5/8" [15.875]	5/8" [15.875]	5/8" [15.875]	5/8" [15.875]	5/8" [15.875]	5/8" [15.875]	5/8" [15.875]	5/8" [15.875]	5/8" [15.875]	/
	143 / 145 TC	inch [mm]	7/8" [22.225]	7/8" [22.225]	7/8" [22.225]	7/8" [22.225]	7/8" [22.225]	7/8" [22.225]	7/8" [22.225]	7/8" [22.225]	7/8" [22.225]	7/8" [22.225]	7/8" [22.225]	7/8" [22.225]	/
75	56 C	inch [mm]	/	/	/	/	/	/	5/8" [15.875]	5/8" [15.875]	5/8" [15.875]	5/8" [15.875]	5/8" [15.875]	5/8" [15.875]	5/8" [15.875]
	143 / 145 TC	inch [mm]	/	7/8" [22.225]	7/8" [22.225]	7/8" [22.225]	7/8" [22.225]	7/8" [22.225]	7/8" [22.225]	7/8" [22.225]	7/8" [22.225]	7/8" [22.225]	7/8" [22.225]	/	/
	182 / 184 TC	inch [mm]	/	1 1/8" [28.575]	1 1/8" [28.575]	1 1/8" [28.575]	1 1/8" [28.575]	/	/	/	/	/	/	/	/
89 90	56 C	inch [mm]	/	/	/	/	/	/	/	/	5/8" [15.875]	5/8" [15.875]	5/8" [15.875]	5/8" [15.875]	/
	143 / 145 TC	inch [mm]	/	/	/	/	/	/	/	7/8" [22.225]	7/8" [22.225]	7/8" [22.225]	7/8" [22.225]	7/8" [22.225]	/
	182 / 184 TC	inch [mm]	/	1 1/8" [28.575]	1 1/8" [28.575]	1 1/8" [28.575]	1 1/8" [28.575]	1 1/8" [28.575]	1 1/8" [28.575]	/	/	/	/	/	/

N.B.: STD mounting of P_M=1
N.B.: El montaje STD de P_M=1



3.8 Accessories

3.8 Accesorios

Output shaft

Eje lento

To be produced on request

A producir bajo petición

Single output shaft
Eje lento standard

Double output shaft
Eje lento doble

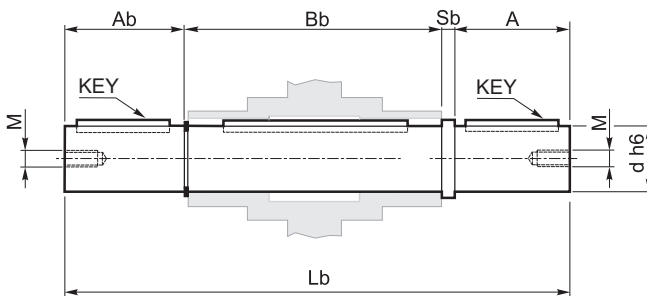
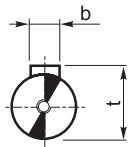
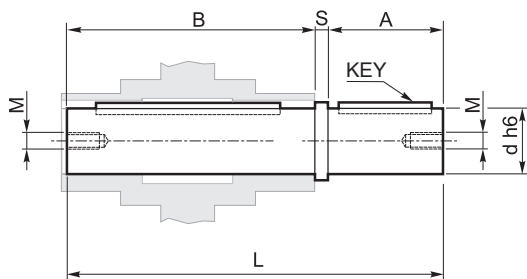

KN		A	B	b	d _{h6}	L	M	S	t	A	A _b	B _b	d _{h6}	L _b	S _b
50	inch	1.969	3.543	0.250	1"	5.653	3/8" - 16	0.14	1.109	1.969	1.969	3.661	1"	7.741	0.14
	[mm]	[50]	[90]	[6.35]	[25.4]	[143.6]	[3.59]	[28.17]		[50]	[50]	[93.2]	[25.4]	[196.8]	[3.59]
63	inch	1.969	4.370	0.250	1"	6.510	3/8" - 16	0.172	1.109	1.969	1.969	4.449	1"	8.558	0.171
	[mm]	[50]	[111]	[6.35]	[25.4]	[165.4]	[4.36]	[28.17]		[50]	[50.0]	[113.2]	[25.4]	[217.6]	[4.34]
75	inch	1.969	4.370	0.250	1 1/4"	6.510	3/8" - 16	0.140	1.362	-					
	[mm]	[50]	[111]	[6.35]	[31.75]	[165.4]	[3.55]	[34.59]							
75	inch	2.375	4.685	0.250	1 1/4"	7.225	1/2" - 13	0.165	1.362	2.375	2.375	4.764	1 1/4"	9.679	0.165
	[mm]	[60.33]	[119]	[6.35]	[31.75]	[183.5]	[4.19]	[34.54]		[60.325]	[60.325]	[121.5]	[31.75]	[246.3]	[4.19]
89-90	inch	3.156	5.472	0.3125	1 3/8"	8.831	1/2" - 13	0.203	1.5135	3.156	3.156	5.571	1 3/8"	12.086	0.203
	[mm]	[80.16]	[139]	[7.938]	[34.925]	[224.3]	[5.16]	[38.443]		[80.16]	[80.16]	[141.5]	[34.925]	[307]	[5.16]

Protection Kit:

Kit de protección:

Torque arm

Brazo de reacción

Output bore / Eje hueco

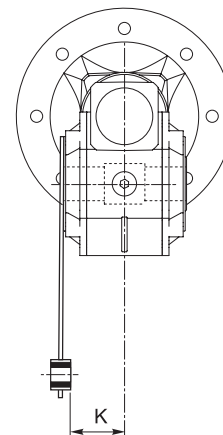
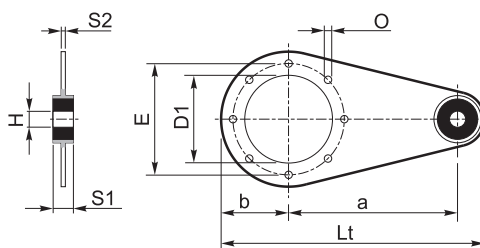
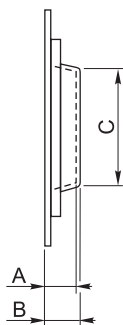

KN	A	B	C	
50	in [mm]	0.591 [15]	0.650 [16.5]	2.126 [54]
63	in [mm]	0.669 [17]	0.748 [19]	2.362 [60]
75	in [mm]	0.689 [17.5]	0.787 [20]	2.756 [70]
89-90	in [mm]	0.846 [21.5]	0.945 [24]	3.150 [80]

KN	a	b	D ₁	E	H	K	L _t	O	S ₁	S ₂	
50	in [mm]	3.937 [100]	1.969 [50]	2.756 [70]	3.346 [85]	0.394 [10]	1.535 [39]	6.772 [172]	0.354 [9]	0.551 [14]	0.197 [5]
63	in [mm]	5.906 [150]	2.165 [55]	3.150 [80]	3.740 [95]	0.394 [10]	1.929 [49]	8.937 [227]	0.354 [9]	0.551 [14]	0.236 [6]
75	in [mm]	7.874 [200]	2.756 [70]	3.740 [95]	4.528 [115]	0.787 [20]	1.870 [47.5]	11.890 [302]	0.354 [9]	0.984 [25]	0.236 [6]
89-90	in [mm]	7.874 [200]	3.150 [80]	4.331 [110]	5.118 [130]	0.787 [20]	2.264 [57.5]	12.283 [312]	0.433 [11]	0.984 [25]	0.236 [6]

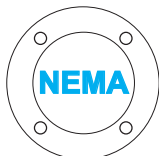

D Helical gear
reducers
RCV

*Reductores de engranajes
helicoidales*
RCV

D1

	INDEX		INDICE	
4.1	Characteristics	<i>Características</i>		D2
4.2	Construction shapes	<i>Formas de fabricación</i>		D2
4.3	Designation	<i>Nomenclatura</i>		D3
4.4	Lubrication	<i>Lubricación</i>		D4
4.5	Quantity of lubricant	<i>Cantidad de lubricante</i>		D4
4.6	Assembly positions	<i>Posiciones de montaje</i>		D5
4.7	Radial load	<i>Cargas radiales</i>		D10
4.8	Technical data	<i>Datos técnicos</i>		D13
4.9	Dimensions	<i>Dimensiones</i>		D22

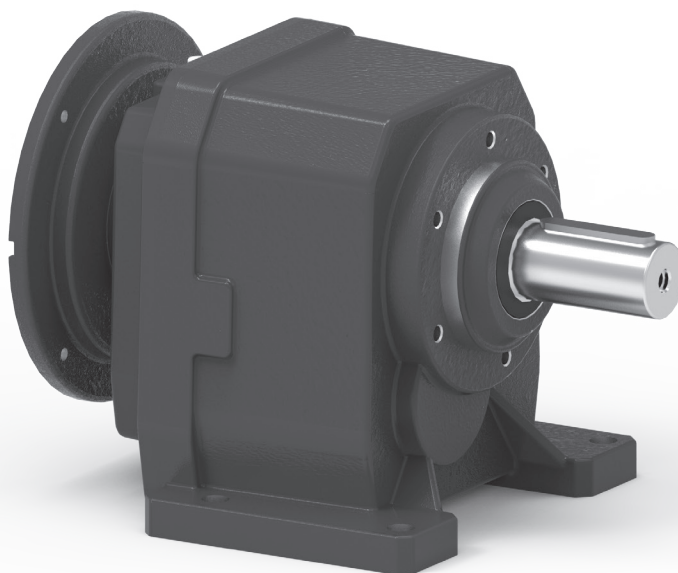



Helical gear reducers RCV

4.1 Characteristics

VARMEC gear reducers and motor-reducers have been entirely designed using leading edge technical computer software. Each single component has been designed and tested in consideration of the maximum loads applicable to the reducer in compliance with AGMA 2001-B88. Casings and flanges made from non varnished aluminium in sizes 141 - 191 - 162 - 202A - 252A - 253A - 302A - 303A. Casings and flanges of all other sizes are made from varnished, highly resistant cast iron. The rounded shape of the casings gives the gear reducers an optimum rigidity and solidity allowing for use in all possible assembly positions. The manufacturing process of the various components is done by modern CNC machinery that gives maximum precision construction. All gears are made from hardened and tempered alloy steel with successive corrections to better the performance and reduce noise levels even whilst running with a load. The input shaft is made from hardened and tempered alloy steel; the output shaft from high strength steel. Gear reducers are varnished with a thermosetting powder based on polyester resins modified with an epoxy resin : colour Burnt Blue RAL5010. Further information on varnish specifics can be had by contacting our technical office

4.2 Construction shapes

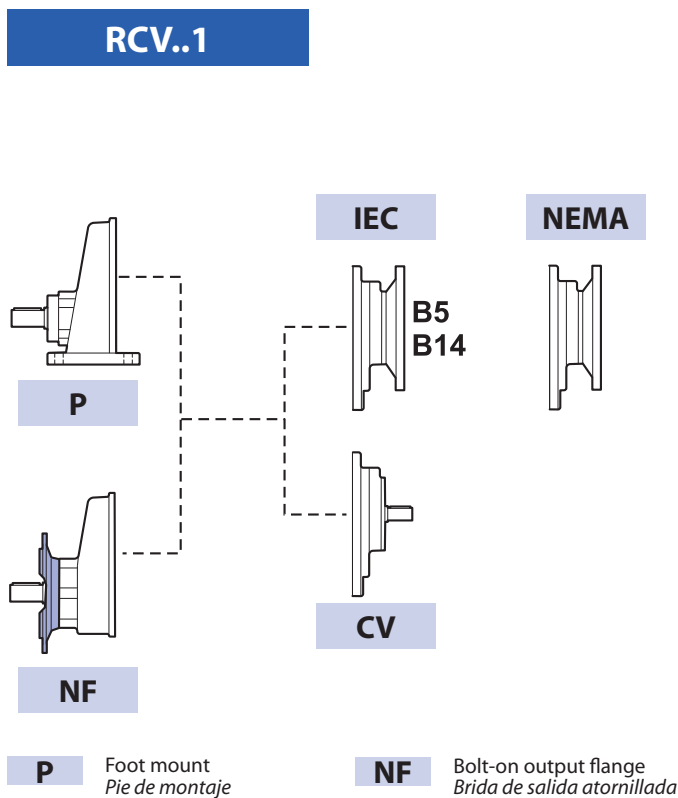

Reductores de engranajes helicoidales RCV

4.1 Características

Los reductores y motorreductores VARMEC han sido proyectados completamente con el apoyo de programas técnicos computarizados. Cada uno de los componentes ha sido proyectado y verificado teniendo en cuenta la máxima carga aplicable al reductor según la normativa AGMA 2001-B88. Carcasas y bridas en aluminio no barnizado de medidas 141 - 191 - 162 - 202A - 252A - 253A - 302A - 303A, carcasas y bridas en fundición de alta resistencia barnizadas en las otras medidas. La forma redondeada de las carcasas confieren al reductor una óptima rigidez y una elevada compatibilidad que permite su utilización en todas las posiciones de montaje posibles. La producción de cada uno de los componentes que integran el reductor se realiza mediante centros mecanizados de control numérico que permiten obtener la máxima precisión constructiva. Todos los engranajes son contruidos en acero 18NiCrMo5 UNI 7846 tratados térmicamente, cementados y cada diente esta rectificado para mejorar su rendimiento y reducir su nivel de sonoridad bajo condiciones de carga. El eje de entrada esta fabricado con acero 16CrNi4 UNI 7846 cementado y templado, y el eje de salida en acero 39NiCrMo3 UNI7845 bonificado. Los reductores estan barnizados con polvo termo-endureciente a base de resinas de poliéster, modificadas con resinas epoxi de color azul RAL5010. Informaciones específicas del barniz se pueden pedir en la oficina técnica.

4.2 Formas de fabricación

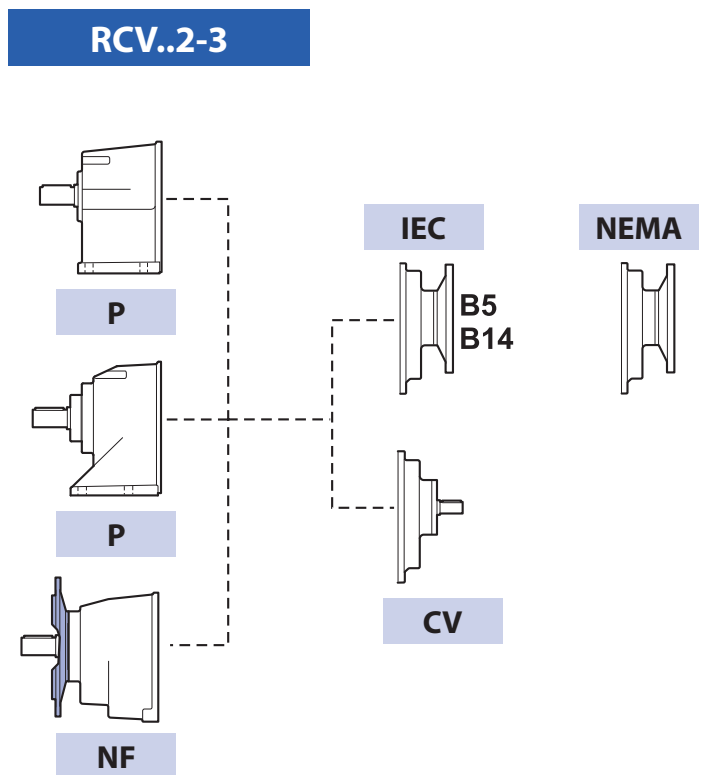



4.3 Designation

4.3 Nomenclatura

GEAR REDUCER / REDUCTOR

RCV 20 2 A P 5.49 NEMA B3 ...

RCV

TYPE OF GEAR REDUCER
TIPO DE REDUCTOR

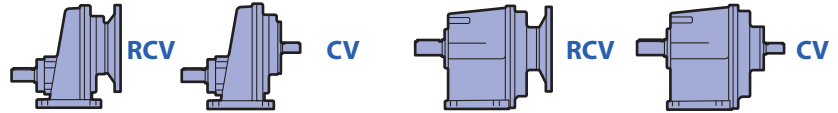

20

SIZE
TAMANO DEL REDUCTOR

14-19-24-28-38

16-20-25-30-35-45-55-58-60

2

N. OF STAGES OF REDUCTION
Nº ESTADOS DE REDUCCION

1

2 - 3

A

VERSION
VERSION

A (Aluminium / Aluminio)
Only for / Solo para
202-252-253-302-303

C (Cast iron / Hierro fundido)
For all sizes of reducer / Para todos reductor

P

STRUCTURAL SHAPE
FORMA CONSTRUCTIVA



14-19-24-28-38

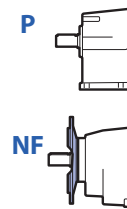

16-20-25-30-35-45-55-58-60

5.49

REDUCTION RATIO
RELACION DE REDUCCION

NEMA

TYPE OF INPUT
TIPO DE ENTRADA

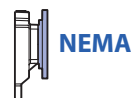

B3

ASSEMBLY POSITION
POSICION DE MONTAJE



....

OPTIONS
OPCIONES



4.4 Lubrication

All VARMEC gear reducers come lubricated with a synthetic oil.

- Gear reducers size RCV-CV 14-19-24-28-16-20-25-30-35 are supplied with life lubrication.
- Gear reducers size RCV-CV 38-45-55-58-60 are usually supplied without lubricant, unless specifically stated otherwise on the order form. Users must therefore add the correct quantity of oil using the oil gauge level before any initial start-up.

For this purpose gear reducers are fitted with an oil filling cap, an oil gauge and a drain plug.

For gear reducers supplied with lubricant, we recommend that once installation is complete customers should substitute the closed plug used only during transport with the oil breather supplied.

We ask that all customers specify their required mounting position so that we at Varmec can fit plugs in the best position for adequate lubrication

Gear reducers are fitted with self-lubricating bearings type 2RS whenever a mounting position requires a gear reducer with a vertical axle and consequently where the shaking of the oil during running times wouldn't be enough to guarantee a correct lubrication to the upper bearings.

4.5 Quantity of lubricant

4.4 Lubrication

Todos los reductores de producción VARMEC son provistos de lubricación a aceite sintético.

- Los reductores de los tamaños RCV-CV 14-19-24-28-16-20-25-30-35 son equipados con lubricación permanente.
- Los reductores de la serie RCV-CV 38- 45-55-58-60 se suministran normalmente sin lubricante, sino está especificado en el pedido, y será el cliente quien antes de la puesta en marcha pondrá la cantidad necesaria de aceite refiriéndose a la línea mediana del tapón.

Los reductores llevan tapones de carga, descarga y nivel de aceite, para los reductores completos de lubricante se recomienda, después de la instalación de sustituir el tapón utilizado para el transporte con el tapón respiradero incluido.

Para preparar la correcta orientación de los tapones para una adecuada lubricación aconsejamos especificar siempre la posición de montaje deseada. En las posiciones de montaje de reductores con eje vertical, donde el batimiento del aceite durante el funcionamiento no es suficiente para garantizar la correcta lubricación de los cojinetes superiores, se instalan cojinetes lubricantes tipo 2RS.

Para preparar la correcta orientación de los tapones para una adecuada lubricación aconsejamos especificar siempre la posición de montaje deseada. En las posiciones de montaje de reductores con eje vertical, donde el batimiento del aceite durante el funcionamiento no es suficiente para garantizar la correcta lubricación de los cojinetes superiores, se instalan cojinetes lubricantes tipo 2RS.

4.5 Cantidad de lubricante

Tab.1

RCV	Assembly position / Posición de montaje									
	B3	B5	B6	B7	B8	V1	V3	V5	V6	
141	0.042 [0.16]				0.050 [0.19]		0.040 [0.15]	0.05 [0.19]		0.040 [0.15]
191	0.074 [0.28]									
241	0.106 [0.4]									
281	0.185 [0.7]				0.106 [0.4]		0.264 [1]	0.185 [0.7]		
381	0.211 [0.8]	0.211 [0.8]	0.396 [1.5]	0.396 [1.5]	0.528 [2.0]	0.238 [0.9]	0.528 [2]	0.264 [1]	0.528 [2]	
162	0.045 [0.17]					0.071 [0.27]	0.066 [0.25]	0.071 [0.27]	0.066 [0.25]	
202A	0.53 [0.2]					0.087 [0.33]	0.074 [0.28]	0.087 [0.33]	0.074 [0.28]	
202-203	0.145 [0.55]									
252A-253A	0.145 [0.55]					0.145 [0.55]	0.158 [0.6]	0.145 [0.55]	0.158 [0.6]	
252-253	0.185 [0.7]									
302A	0.264 [1]					0.304 [1.15]	0.290 [1.1]	0.304 [1.15]	0.290 [1.1]	
303A	0.264 [1]					0.356 [1.35]	0.343 [1.3]	0.356 [1.35]	0.343 [1.3]	
302-303	0.343 [1.3]					0.396 [1.5]	0.343 [1.3]	0.396 [1.5]	0.343 [1.3]	
352-353	0.343 [1.3]					0.396 [1.5]	0.343 [1.3]	0.396 [1.5]	0.343 [1.3]	
452-453	0.660 [2.5]	0.607 [2.3]	0.607 [2.3]	0.607 [2.3]	0.528 [2]	0.766 [2.9]	0.898 [3.4]	0.792 [3]	0.898 [3.4]	
552-553	1.003 [3.8]	0.924 [3.5]	0.924 [3.5]	0.924 [3.5]	0.792 [3]	1.188 [4.5]	1.531 [5.8]	1.320 [5]	1.531 [5.5]	
582-583	1.294 [4.9]	1.294 [4.9]	1.294 [4.9]	1.294 [4.9]	1.478 [5.6]	1.927 [7.3]	2.244 [8.5]	1.927 [7.3]	2.244 [8.5]	
602-603	2.244 [8.5]	2.244 [8.5]	2.112 [8]	2.112 [8]	2.244 [8.5]	3.300 [12.5]	3.168 [12]	3.300 [12.5]	3.168 [12]	

Permanent lubrication / Lubricación permanente

Amount of oil expressed in gal [lt] / Cantidad de aceite expresada en gal [lt]



4.6 Assembly positions

The tables below should be used as a reference for the interpretation of the assembly positions, the position of the plugs and the quantities of lubricant.

4.6 Posiciones de montaje

Las tablas siguientes sirven de referencia para interpretar las posiciones de montaje, la colocación de los tapones y la cantidad de lubricante.

RCV..1 / P

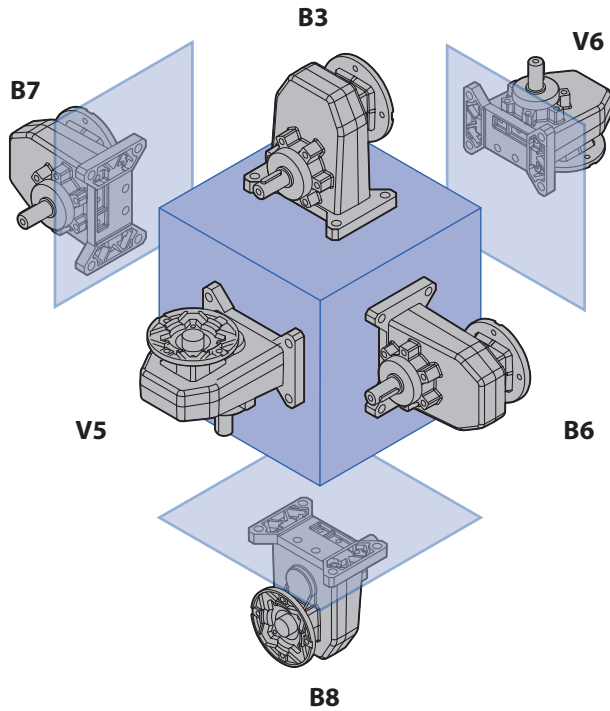

RCV..1 / NF

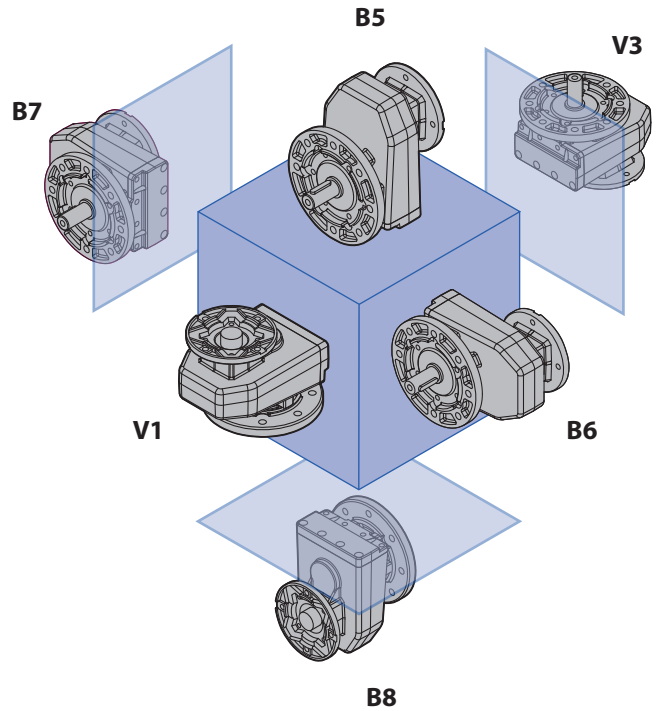

RCV..2-3 / P

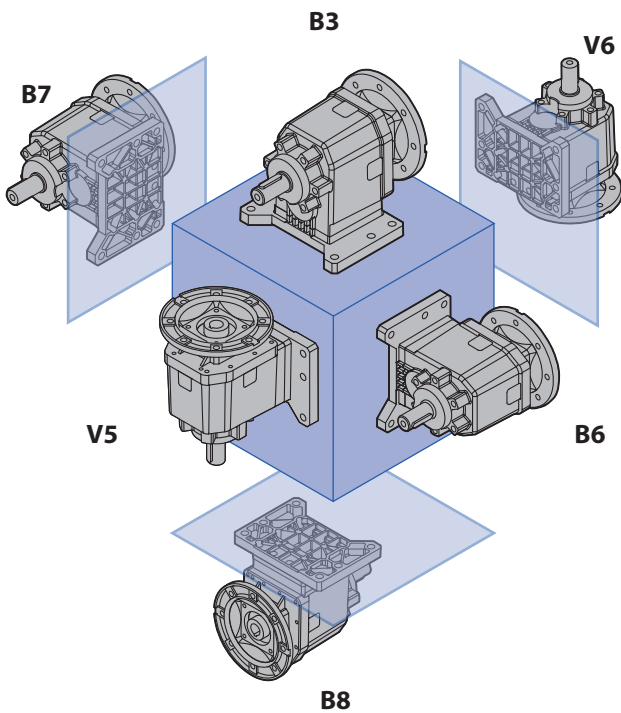

RCV..2-3 / NF

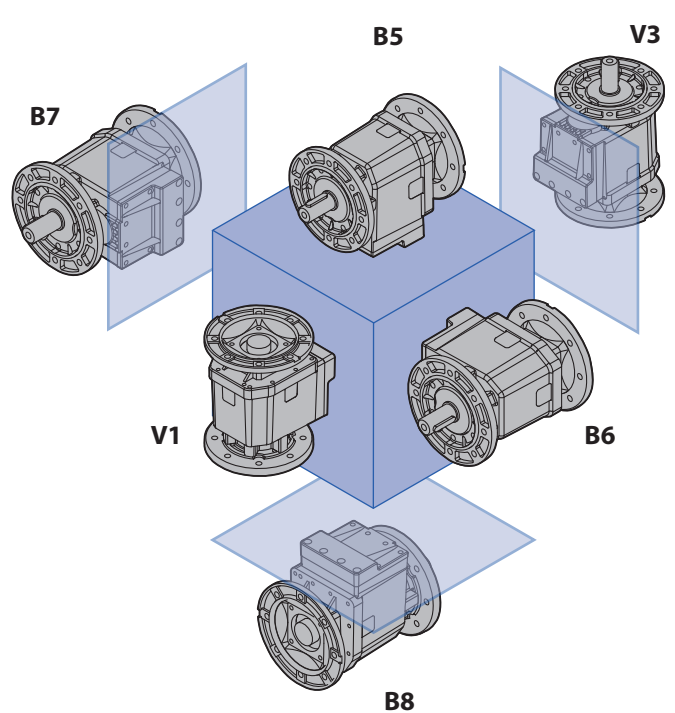



RCV ...1 / P			
B3	...NEMA	B8	...NEMA
B6	...NEMA	B7	...NEMA
V5	...NEMA	V6	...NEMA

A = Standard

- Filler cap / Carga aceite
- Oil level plug / Nivel aceite
- Drain plug / Descarga de aceite

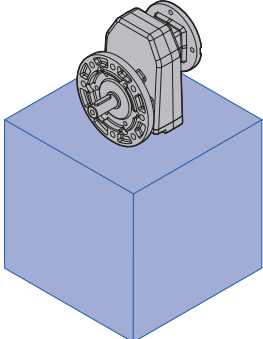
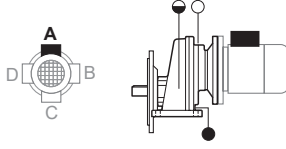
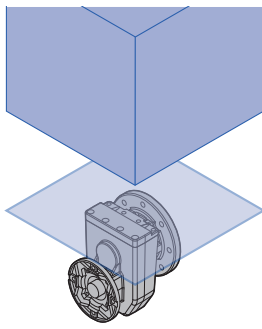
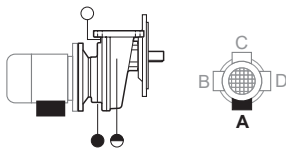
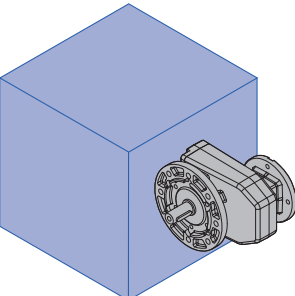
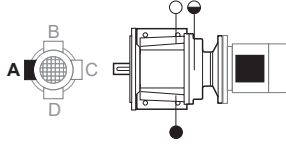
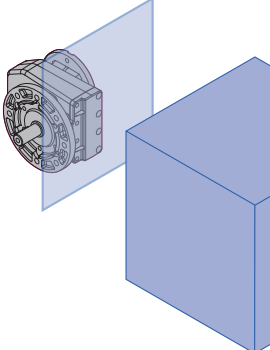
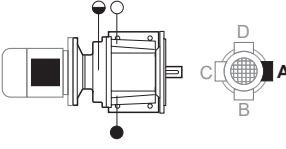
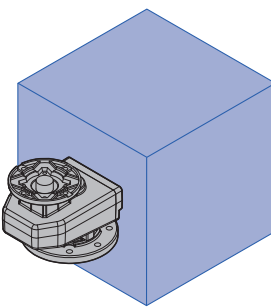
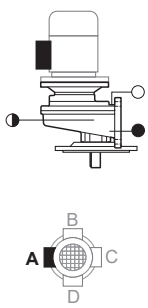
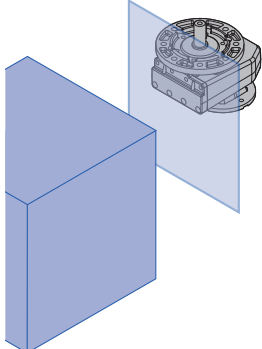
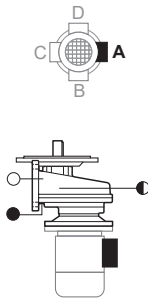

RCV ...1 / NF			
B5	...NEMA	B8	...NEMA
			
B6	...NEMA	B7	...NEMA
			
V1	...NEMA	V3	...NEMA
			

A = Standard

- Filler cap / Carga aceite
- ◐ Oil level plug / Nivel aceite
- Drain plug / Descarga de aceite



RCV ...2-3 / P

B3	...NEMA	B8	...NEMA
B6	...NEMA	B7	...NEMA
V5	...NEMA	V6	...NEMA

A = Standard

- ▽ Breather plug / Tapón respiradero
- Filler cap / Carga aceite
- Oil level plug / Nivel aceite
- Drain plug / Descarga de aceite

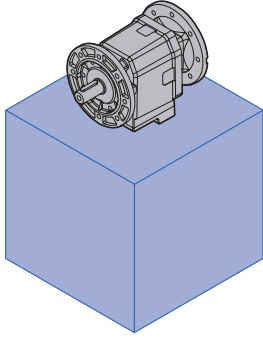
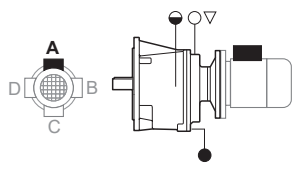
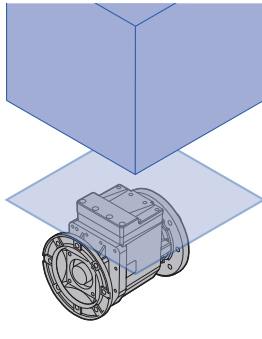
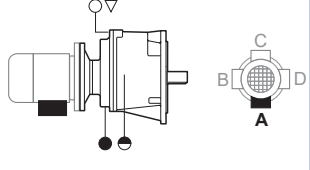
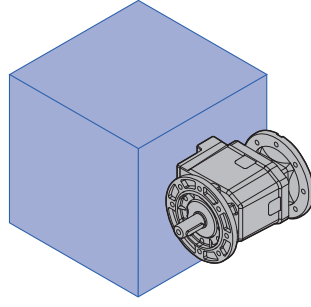
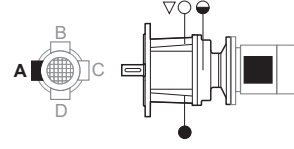
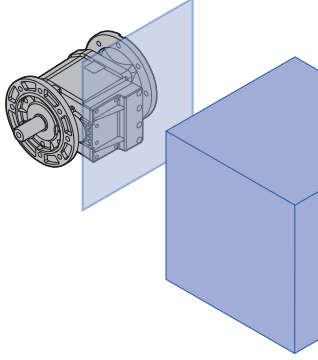
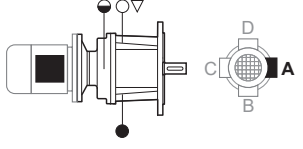
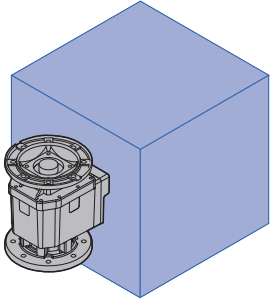
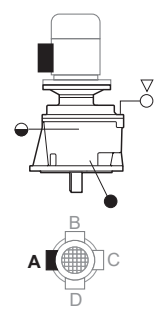
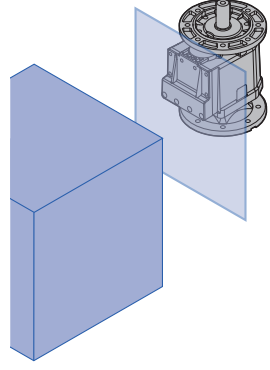
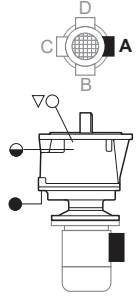

RCV ...2-3 / NF			
B5	...NEMA	B8	...NEMA
			
B6	...NEMA	B7	...NEMA
			
V1	...NEMA	V3	...NEMA
			

A = Standard

- ▽ Breather plug / Tapón respiradero
- Filler cap / Carga aceite
- Oil level plug / Nivel aceite
- Drain plug / Descarga de aceite



4.7 Radial load

Any transmission device coupled to the input and output shaft generates radial loads.

The load values reported in the table, depending on input and output speed, are to be considered as acting at the half-way point of the projection; if the load is applied at 1/3 of the projection, increase the values in the table by 25%; if the load is applied at 2/3, reduce the values by 25%.

With regard to double projecting shafts, each end can sustain a radial load which equals 3/5 of the values listed in the table, on condition that they act in the same direction and have the same intensity.

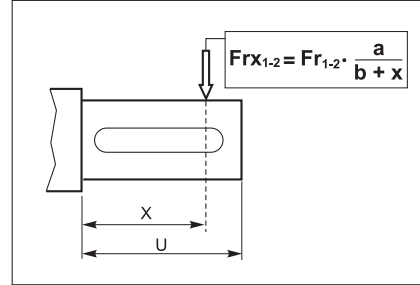
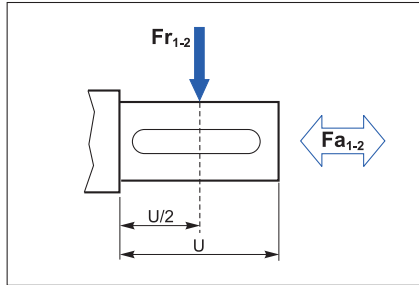

4.7 Cargas radiales

Cada clase de órgano de transmisión que es conectado al eje de entrada y salida determina cargas radiales.

Los valores señalados en la tabla en función a las varias velocidades de entrada y salida se suponen aplicándolas en la mitad del eje como fuerzas agentes a esta; para una ubicación de 1/3 de la longitud se aumentará hasta un 25% los valores de la tabla, mientras para una posición de 2/3 de la longitud se disminuirá los mismos valores a un 25%.

En los ejes con salida doble, cada extremidad puede soportar una carga radial igual a 3/5 del valor de la tabla, siempre y cuando las cargas aplicables sean de igual intensidad y reaccionen en el mismo sentido.

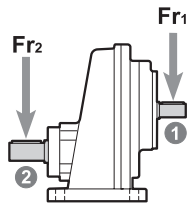

		Fr_1				
n_1 [min ⁻¹]		CV				
		141	191	241	281	381
2800	lbf	111	166	166	222	388
	[N]	[200]	[300]	[300]	[400]	[700]
1400	lbf	166	277	277	333	583
	[N]	[300]	[500]	[500]	[600]	[1050]
900	lbf	194	322	322	388	677
	[N]	[350]	[580]	[580]	[700]	[1220]
700	lbf	211	350	350	422	732
	[N]	[380]	[630]	[630]	[760]	[1320]
500	lbf	239	388	388	472	821
	[N]	[430]	[700]	[700]	[850]	[1480]
300	lbf	277	460	460	555	971
	[N]	[500]	[830]	[830]	[1000]	[1750]
a	inch	2.413	2.984	2.984	3.898	4.709
	[mm]	[61.3]	[75.8]	[75.8]	[99]	[119.6]
b	inch	1.626	2.197	2.197	2.913	3.528
	[mm]	[41.3]	[55.8]	[55.8]	[74]	[89.6]



4.7 Radial load

4.7 Cargas radiales

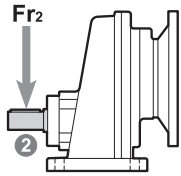

		Fr_2				
n_2 [min ⁻¹]		RCV - CV				
		141	191	241	281	381
900	lbf	388	388	388	804	1137
	[N]	[700]	[700]	[700]	[1450]	[2050]
600	lbf	444	555	555	888	1332
	[N]	[800]	[1000]	[1000]	[1600]	[2400]
450	lbf	527	610	610	971	1470
	[N]	[950]	[1100]	[1100]	[1750]	[2650]
400	lbf	527	638	638	1026	1526
	[N]	[950]	[1150]	[1150]	[1850]	[2750]
350	lbf	583	666	666	1054	1581
	[N]	[1050]	[1200]	[1200]	[1900]	[2850]
300	lbf	610	694	694	1110	1664
	[N]	[1100]	[1250]	[1250]	[2000]	[3000]
250	lbf	638	749	749	1193	1775
	[N]	[1150]	[1350]	[1350]	[2150]	[3200]
200	lbf	666	804	804	1276	1942
	[N]	[1200]	[1450]	[1450]	[2300]	[3500]
150	lbf	694	888	888	1415	2108
	[N]	[1250]	[1600]	[1600]	[2550]	[3800]
100	lbf	694	999	999	1609	2413
	[N]	[1250]	[1800]	[1800]	[2900]	[4350]
50	lbf	721	1276	1276	2053	3051
	[N]	[1300]	[2300]	[2300]	[3700]	[5500]
a	inch	3.465	3.937	3.091	3.878	4.626
	[mm]	[88]	[100]	[78.5]	[98.5]	[117.5]
b	inch	2.874	3.150	2.106	2.697	3.051
	[mm]	[73]	[80]	[53.5]	[68.5]	[77.5]



4.7 Radial load

4.7 Cargas radiales

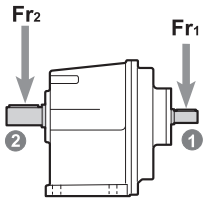

		Fr_1														
n_1 [min ⁻¹]		CV														
		162	202 202A	203	252 252A	253 253A	302 302A	303 303A	352	353	452	453	552 582	553 583	602	603
2800	lbf [N]	111 [200]	166 [300]	111 [200]	166 [300]	111 [200]	222 [400]	166 [300]	250 [450]	166 [300]	388 [700]	222 [400]	749 [1350]	333 [600]	749 [1350]	749 [1350]
1400	lbf [N]	166 [300]	277 [500]	166 [300]	277 [500]	166 [300]	333 [600]	277 [500]	388 [700]	277 [500]	583 [1050]	333 [600]	1110 [2000]	527 [950]	1110 [2000]	1110 [2000]
900	lbf [N]	194 [350]	322 [580]	194 [350]	322 [580]	194 [350]	388 [700]	322 [580]	449 [810]	322 [580]	677 [1220]	388 [700]	1287 [2320]	610 [1100]	1287 [2320]	1287 [2320]
700	lbf [N]	211 [380]	350 [630]	211 [380]	350 [630]	211 [380]	422 [760]	350 [630]	488 [880]	350 [630]	732 [1320]	422 [760]	1398 [2520]	666 [1200]	1398 [2520]	1398 [2520]
500	lbf [N]	239 [430]	388 [700]	239 [430]	388 [700]	239 [430]	472 [850]	388 [700]	544 [980]	388 [700]	821 [1480]	472 [850]	1570 [2830]	749 [1350]	1570 [2830]	1570 [2830]
300	lbf [N]	277 [500]	460 [830]	277 [500]	460 [830]	277 [500]	555 [1000]	460 [830]	644 [1160]	460 [830]	971 [1750]	555 [1000]	1859 [3350]	888 [1600]	1859 [3350]	1859 [3350]
a	inch [mm]	2.413 [61.3]	2.984 [75.8]	2.413 [61.3]	2.984 [75.8]	2.413 [61.3]	3.898 [99]	2.984 [75.8]	3.898 [99]	2.984 [75.8]	4.709 [119.6]	3.898 [99]	6.339 [161]	4.709 [119.6]	6.339 [161]	6.339 [161]
b	inch [mm]	1.626 [41.3]	2.197 [55.8]	1.626 [41.3]	2.197 [55.8]	1.626 [41.3]	2.913 [74]	2.197 [55.8]	2.913 [74]	2.197 [55.8]	3.528 [89.6]	2.913 [74]	4.764 [121]	3.528 [89.6]	4.764 [121]	4.764 [121]

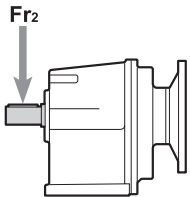

		Fr_2									
n_2 [min ⁻¹]		RCV-CV									
		162	202-203 202A	252-253 252A-253A	302-303	302A-303A	352-353	452-453	552-553	582-583	602-603
400	lbf [N]	388 [700]	527 [950]	594 [1070]	1082 [1950]	1221 [2200]	1720 [3100]	2280 [4110]	2691 [4850]	3939 [7100]	6103 [11000]
300	lbf [N]	444 [800]	577 [1040]	655 [1180]	1126 [2030]	1359 [2450]	1775 [3200]	2341 [4220]	3301 [5950]	4799 [8650]	6269 [11300]
250	lbf [N]	444 [800]	671 [1210]	766 [1380]	1315 [2370]	1426 [2570]	1875 [3380]	2474 [4460]	3329 [6000]	5132 [9250]	6602 [11900]
200	lbf [N]	472 [850]	721 [1300]	827 [1490]	1420 [2560]	1581 [2850]	2008 [3620]	2646 [4770]	3606 [6500]	5548 [10000]	6658 [12000]
150	lbf [N]	555 [1000]	793 [1430]	910 [1640]	1559 [2810]	1720 [3100]	2186 [3940]	2879 [5190]	4161 [7500]	5714 [10300]	6769 [12200]
100	lbf [N]	610 [1100]	960 [1730]	1037 [1870]	1786 [3220]	1942 [3500]	2469 [4450]	3251 [5860]	4716 [8500]	7296 [13150]	8045 [14500]
80	lbf [N]	666 [1200]	1082 [1950]	1115 [2010]	1920 [3460]	2164 [3900]	2630 [4740]	3468 [6250]	5271 [9500]	7490 [13500]	8766 [15800]
60	lbf [N]	777 [1400]	1221 [2200]	1232 [2220]	2119 [3820]	2275 [4100]	2874 [5180]	3789 [6830]	6103 [11000]	9432 [17000]	10319 [18600]
40	lbf [N]	943 [1700]	1332 [2400]	1409 [2540]	2424 [4370]	2774 [5000]	3246 [5850]	4283 [7720]	7767 [14000]	10985 [19800]	12039 [21700]
20	lbf [N]	1110 [2000]	1664 [3000]	1775 [3200]	3051 [5500]	3051 [5500]	3995 [7200]	5271 [9500]	8877 [16000]	13870 [25000]	14980 [27000]
a	inch [mm]	3.327 [84.5]	3.858 [98]	3.543 [90]	3.720 [94.5]	5.846 [148.5]	5.000 [127]	5.354 [136]	7.087 [180]	8.622 [219]	9.862 [250.5]
b	inch [mm]	2.539 [64.5]	3.071 [78]	2.559 [65]	2.539 [64.5]	4.665 [118.5]	3.425 [87]	3.583 [91]	4.921 [125]	6.260 [159]	7.500 [190.5]

4.8 Technical data
4.8 Datos técnicos

RCV	i	$n_1 = 1750 \text{ min}^{-1}$					FS'	 NEMA
		n_2 min^{-1}	Ft·lb	T_2 Nm	Hp	P_1 kW		
141	1.29	1357	11	15	2.9	2.2	1.0	56 C
	2.33	751	18	24	2.6	1.9		
	2.79	627	20	27	2.4	1.8		
	3.4	515	20	27	2.0	1.5		
	4.24	413	21	28	1.7	1.2		
	4.79	365	21	29	1.5	1.1		
	5.47	320	21	29	1.3	0.99		
	7.46	235	22	30	1.0	0.75		
	8.17	214	22	30	0.92	0.69		
191	1.26	1389	15	20	4.0	3.0	1.0	143/145 TC 56 C
	2.23	785	22	30	3.4	2.5		
	2.73	641	23	31	2.8	2.1		
	3.22	543	24	32	2.5	1.9		
	4.11	426	30	41	2.5	1.9		
	4.71	372	32	44	2.3	1.7		
	5.47	320	32	44	2.0	1.5		
	7.82	224	35	47	1.5	1.1		
	9.78	179	37	50	1.3	0.96		
241	1.26	1389	15	20	4.0	3.0	1.0	143/145 TC 56 C
	2.23	785	22	30	3.4	2.5		
	2.73	641	23	31	2.8	2.1		
	3.22	543	24	32	2.5	1.9		
	4.11	426	30	41	2.5	1.9		
	4.71	372	32	44	2.3	1.7		
	5.47	320	32	44	2.0	1.5		
	7.82	224	35	47	1.5	1.1		
	9.78	179	37	50	1.3	0.96		
281	1.14	1535	30	40	8.8	6.6	1.0	182/184 TC 143/145 TC
	1.56	1122	35	47	7.6	5.6		
	2.29	764	45	61	6.7	5.0		
	2.83	618	53	72	6.4	4.8		
	3.38	518	53	72	5.3	4.0		
	3.84	456	53	72	4.7	3.5		
	4.41	397	54	73	4.2	3.1		
	5.57	314	61	82	3.7	2.8		
	7.36	238	80	108	3.7	2.7		
381	1.63	1074	68	92	14.2	10.6	1.0	213/215 TC 182/184 TC 143/145 TC
	2.29	764	69	94	10.3	7.7		
	3	583	81	110	9.2	6.9		
	3.38	518	81	110	8.2	6.1		
	4.11	426	85	115	7.0	5.2		
	4.75	368	93	126	6.7	5.0		
	5.57	314	96	130	5.9	4.4		
	7.36	238	97	132	4.5	3.4		
	10.4	168	102	138	3.3	2.48		





4.8 Technical data

4.8 Datos técnicos

RCV	i	$n_1 = 1750 \text{ min}^{-1}$					FS'	 NEMA
		n_2 min^{-1}	Ft-lb	T_2 Nm	Hp	P_1 kW		
162	3.7	473	27	37	2.6	1.9	1.0	56 C
	5.1	343	30	41	2.1	1.6		
	7.11	246	35	48	1.7	1.3		
	7.62	230	35	47	1.6	1.2		
	9.8	179	40	54	1.4	1.1		
	11.95	146	44	60	1.3	1.0		
	14.63	120	46	62	1.1	0.82		
	16.47	106	47	64	1.0	0.75		
	20.74	84	49	66	0.82	0.61		
	24.59	71	51	69	0.73	0.54		
	25.51	69	49	66	0.67	0.50		
	28.57	61	49	67	0.61	0.45		
	35.14	50	49	66	0.49	0.36		
	42.67	41	51	69	0.42	0.31		
52.48	33	52	71	0.35	0.26			
202A	3.81	459	38	52	3.5	2.6	1.0	143/145 TC 56 C
	4.66	376	45	61	3.4	2.5		
	5.49	319	54	73	3.4	2.6		
	6.46	271	52	70	2.8	2.1		
	7.75	226	53	72	2.4	1.8		
	8.57	204	54	73	2.2	1.6		
	9.92	176	57	77	2.0	1.5		
	11.67	150	58	78	1.7	1.3		
	14	125	58	78	1.4	1.1		
	15.48	113	58	78	1.3	0.97		
	18.01	97	72	97	1.4	1.0		
	21.19	83	71	96	1.2	0.87		
	25.43	69	78	106	1.1	0.80		
	28.13	62	76	103	0.95	0.71		
	31.71	55	80	108	0.88	0.66		
	37.31	47	79	107	0.74	0.55		
	44.77	39	79	107	0.62	0.46		
	49.52	35	77	104	0.54	0.41		
54.2	32	76	103	0.49	0.37			
60.43	29	66	90	0.39	0.29			
202	3.81	459	38	52	3.5	2.6	1.0	143/145 TC 56 C
	4.66	376	45	61	3.4	2.5		
	5.49	319	54	73	3.4	2.6		
	6.46	271	52	70	2.8	2.1		
	7.75	226	53	72	2.4	1.8		
	8.57	204	54	73	2.2	1.6		
	9.92	176	57	77	2.0	1.5		
	11.67	150	58	78	1.7	1.3		
	14	125	58	78	1.4	1.1		
	15.48	113	58	78	1.3	0.97		
	18.01	97	72	97	1.4	1.0		
	21.19	83	71	96	1.2	0.87		
	25.43	69	78	106	1.1	0.80		
	28.13	62	76	103	0.95	0.71		
	31.71	55	80	108	0.88	0.66		
	37.31	47	79	107	0.74	0.55		
	44.77	39	79	107	0.62	0.46		
	49.52	35	77	104	0.54	0.41		
54.2	32	76	103	0.49	0.37			
60.43	29	66	90	0.39	0.29			

4.8 Technical data
4.8 Datos técnicos

RCV	i	$n_1 = 1750 \text{ min}^{-1}$					FS'	 NEMA
		n_2 min^{-1}	Ft·lb	T_2 Nm	Hp	P_1 kW		
203	58.1	30	79	107	0.49	0.36	1.0	56 C
	64.3	27	77	104	0.43	0.32		
	69.2	25	80	109	0.42	0.31		
	81.4	21	80	108	0.35	0.26		
	97.7	18	79	107	0.29	0.22		
	108.1	16	77	105	0.26	0.19		
	120.1	15	80	109	0.24	0.18		
	141.3	12	80	108	0.20	0.15		
	169.5	10	80	108	0.17	0.13		
187.5	9	79	107	0.15	0.11			
252A	3.7	473	71	96	6.7	5.0	1.0	143/145 TC 56 C
	4.33	404	83	112	6.7	5.0		
	5.02	349	97	132	6.8	5.1		
	5.92	296	106	143	6.2	4.7		
	6.47	270	108	146	5.8	4.4		
	7.88	222	108	147	4.8	3.6		
	8.93	196	113	153	4.4	3.3		
	9.41	186	112	152	4.2	3.1		
	10.53	166	115	156	3.8	2.9		
	11.51	152	112	152	3.4	2.55		
	14.01	125	113	153	2.8	2.1		
	16.42	107	142	192	3.0	2.26		
	19.35	90	149	202	2.7	2.01		
	21.16	83	145	196	2.40	1.79		
	25.75	68	139	189	1.90	1.42		
	31.27	56	150	203	1.68	1.25		
	36.86	47	152	206	1.45	1.08		
	40.29	43	147	199	1.28	0.95		
	49.04	36	141	191	1.01	0.75		
53.95	32	129	175	0.84	0.63			
61.33	29	132	179	0.76	0.56			
67.47	26	129	175	0.67	0.50			
253A	63.09	28	132	179	0.75	0.56	1.0	56 C
	74.36	24	139	188	0.67	0.50		
	81.29	22	140	190	0.62	0.46		
	98.94	18	143	194	0.52	0.39		
	108.83	16	142	193	0.47	0.35		
	120.15	15	151	205	0.45	0.34		
	141.61	12	159	215	0.40	0.30		
	154.81	11	152	206	0.35	0.26		
	188.42	9	141	191	0.27	0.20		
	207.26	8	135	183	0.23	0.17		





4.8 Technical data

4.8 Datos técnicos

RCV	i	$n_1 = 1750 \text{ min}^{-1}$					FS'	 NEMA
		n_2 min^{-1}	Ft-lb	T_2 Nm	Hp	P_1 kW		
252	3.7	473	71	96	6.7	5.0	1.0	143/145 TC 56 C
	4.33	404	83	112	6.7	5.0		
	5.02	349	97	132	6.8	5.1		
	5.92	296	106	143	6.2	4.7		
	6.47	270	108	146	5.8	4.4		
	7.88	222	108	147	4.8	3.6		
	8.93	196	113	153	4.4	3.3		
	9.41	186	112	152	4.2	3.1		
	10.53	166	115	156	3.8	2.9		
	11.51	152	112	152	3.4	2.55		
	14.01	125	113	153	2.8	2.1		
	16.42	107	142	192	3.0	2.26		
	19.35	90	149	202	2.7	2.01		
	21.16	83	145	196	2.40	1.79		
	25.75	68	139	189	1.90	1.42		
	31.27	56	150	203	1.68	1.25		
	36.86	47	152	206	1.45	1.08		
	40.29	43	147	199	1.28	0.95		
	49.04	36	141	191	1.01	0.75		
53.95	32	129	175	0.84	0.63			
61.33	29	132	179	0.76	0.56			
67.47	26	129	175	0.67	0.50			
253	60.1	29	141	191	0.84	0.63	1.0	56 C
	69.6	25	151	205	0.78	0.58		
	82	21	153	207	0.67	0.50		
	89.7	20	148	201	0.59	0.44		
	109.1	16	142	193	0.47	0.35		
	122.5	14	152	206	0.44	0.33		
	144.4	12	154	208	0.38	0.28		
	157.9	11	149	202	0.34	0.25		
	192.1	9	145	197	0.27	0.20		
	302	3.74	468	179	243	16.8		
4.56		384	190	258	14.6	10.9		
5.11		342	185	251	12.7	9.5		
6.22		281	187	253	10.5	7.8		
6.93		253	186	252	9.4	7.0		
7.51		233	182	246	8.5	6.3		
7.78		225	193	261	8.7	6.5		
9.14		191	213	288	8.2	6.1		
10.18		172	218	296	7.5	5.6		
11.43		153	225	305	6.9	5.1		
12.62		139	206	279	5.7	4.3		
15.37		114	218	295	5.0	3.7		
17.11		102	224	303	4.6	3.4		
19.21		91	229	310	4.2	3.1		
24.19		72	210	285	3.0	2.3		
29.45		59	221	300	2.6	2.0		
32.8		53	227	308	2.4	1.8		
36.82		48	232	315	2.2	1.7		



4.8 Technical data
4.8 Datos técnicos

RCV	i	$n_1 = 1750 \text{ min}^{-1}$					FS'	 NEMA
		n_2 min ⁻¹	Ft-lb	T ₂ Nm	Hp	P ₁ kW		
303	41.2	42	229	310	1.99	1.48	1.0	143/145 TC 56 C
	46.2	38	233	316	1.81	1.35		
	54	32	214	290	1.42	1.06		
	65.8	27	224	304	1.22	0.91		
	73.6	24	229	310	1.11	0.83		
	82.2	21	234	317	1.02	0.76		
	99.3	18	215	292	0.78	0.58		
	120.9	14	226	306	0.67	0.50		
	134.7	13	232	314	0.62	0.46		
	151.1	12	236	320	0.56	0.42		
	189.2	9	221	299	0.42	0.31		
	230.3	8	236	320	0.37	0.27		
	256.5	7	246	334	0.34	0.26		
287.9	6	255	346	0.32	0.24			
302A	3.78	463	114	155	10.6	7.9	1.0	143/145 TC 56 C
	4.4	398	131	177	10.4	7.8		
	5.2	337	147	199	9.9	7.4		
	6.27	279	156	211	8.7	6.5		
	7.76	226	168	227	7.6	5.6		
	8.75	200	178	241	7.1	5.3		
	10.18	172	187	254	6.5	4.8		
	12.03	145	196	265	5.7	4.2		
	14.5	121	208	282	5.0	3.8		
	17.95	97	215	291	4.2	3.1		
	19.58	89	230	311	4.1	3.1		
	22.8	77	246	333	3.8	2.8		
	26.94	65	258	349	3.4	2.5		
	32.45	54	249	337	2.7	2.0		
	40.18	44	221	300	1.9	1.4		
	44.06	40	226	306	1.8	1.3		
	46.59	38	234	317	1.8	1.3		
53.08	33	254	344	1.7	1.3			
57.69	30	221	299	1.3	1.0			
65.72	27	220	298	1.2	0.9			
303A	64.91	27	272	369	1.50	1.1	1.0	143/145 TC 56 C
	75.58	23	275	373	1.30	0.97		
	89.31	20	271	367	1.09	0.81		
	107.61	16	266	361	0.89	0.66		
	125.53	14	263	357	0.75	0.56		
	133.23	13	236	320	0.63	0.47		
	146.18	12	259	351	0.63	0.47		
	172.72	10	258	349	0.53	0.40		
	181.4	10	254	344	0.50	0.37		
	208.12	8	272	368	0.47	0.35		
	249.59	7	280	379	0.40	0.30		
	300.74	6	280	380	0.33	0.25		
	372.35	5	244	330	0.23	0.17		





4.8 Technical data

4.8 Datos técnicos

RCV	i	$n_1 = 1750 \text{ min}^{-1}$					FS'	 NEMA
		n_2 min ⁻¹	Ft-lb	T ₂ Nm	Hp	P ₁ kW		
352	3.74	468	232	314	21.7	16.2	1.0	182/184 TC 143/145 TC
	4.56	384	245	332	18.8	14.0		
	5.11	342	255	346	17.5	13.1		
	6.22	281	269	364	15.1	11.3		
	6.93	253	276	374	14.0	10.4		
	7.51	233	260	352	12.1	9.0		
	7.78	225	283	384	12.8	9.5		
	9.14	191	273	370	10.5	7.8		
	10.18	172	281	381	9.7	7.2		
	11.43	153	289	391	8.8	6.6		
	12.62	139	266	360	7.4	5.5		
	15.37	114	280	379	6.4	4.8		
	17.11	102	286	388	5.9	4.4		
	19.21	91	294	399	5.4	4.0		
	24.19	72	272	369	3.9	2.9		
	29.45	59	288	390	3.4	2.6		
32.8	53	292	396	3.1	2.3			
36.82	48	297	403	2.8	2.1			
353	41.2	42	292	396	2.54	1.9	1.0	143/145 TC 56 C
	46.2	38	300	406	2.32	1.7		
	54	32	275	372	1.82	1.4		
	65.8	27	289	391	1.57	1.2		
	73.6	24	294	398	1.43	1.1		
	82.2	21	301	408	1.31	0.98		
	99.3	18	278	377	1.00	0.75		
	120.9	14	290	393	0.86	0.64		
	134.7	13	295	400	0.78	0.59		
	151.1	12	303	411	0.72	0.54		
	189.2	9	283	383	0.53	0.40		
	230.3	8	301	408	0.47	0.35		
	256.5	7	316	428	0.44	0.33		
	287.9	6	325	440	0.40	0.30		
452	4.42	396	424	574	33.6	25.1	1.0	213/215 TC 182/184 TC 143/145 TC
	4.89	358	422	572	30.3	22.6		
	5.43	322	423	573	27.3	20.4		
	6.07	288	421	571	24.3	18.1		
	8.14	215	458	621	19.7	14.7		
	9	194	472	640	18.4	13.7		
	10	175	486	659	17.0	12.7		
	11.18	157	489	662	15.3	11.4		
	12.89	136	468	634	12.7	9.5		
	14.25	123	481	652	11.8	8.8		
	15.83	111	495	671	11.0	8.2		
	17.7	99	497	674	9.9	7.3		
	19.99	88	477	646	8.4	6.2		
	22.09	79	492	667	7.8	5.8		
	24.55	71	504	683	7.2	5.4		
	27.45	64	504	683	6.4	4.8		
	30.93	57	518	702	5.9	4.4		
	31.2	56	448	607	5.0	3.8		
	34.67	50	497	674	5.0	3.8		
	38.76	45	408	553	3.7	2.8		
43.68	40	460	623	3.7	2.8			



4.8 Technical data
4.8 Datos técnicos

RCV	i	$n_1 = 1750 \text{ min}^{-1}$					FS'	 NEMA
		n_2 min^{-1}	Ft-lb	T_2 Nm	Hp	P_1 kW		
453	31.1	56	482	653	5.55	4.1	1.0	182/184 TC 143/145 TC
	34.4	51	494	669	5.14	3.8		
	38.2	46	508	688	4.76	3.5		
	42.7	41	508	688	4.26	3.2		
	45.7	38	484	656	3.79	2.8		
	50.5	35	497	674	3.53	2.63		
	56.1	31	511	692	3.26	2.43		
	62.7	28	512	694	2.92	2.18		
	76.8	23	487	660	2.27	1.69		
	84.9	21	499	676	2.10	1.57		
	94.3	19	515	698	1.96	1.46		
	105.5	17	511	693	1.74	1.29		
	123.81	14	539	730	1.56	1.16		
	147.2	12	488	661	1.19	0.88		
	162.7	11	501	679	1.10	0.82		
	180.7	10	523	708	1.04	0.77		
202.1	9	528	716	0.94	0.70			
227.7	8	553	749	0.87	0.65			
552	2.26	774	335	454	54.7	40.8	1.0	284/286 TC 254/256 TC 213/215 TC 182/184 TC
	2.78	629	406	550	51.2	38.2		
	3.17	552	413	560	45.7	34.1		
	3.68	476	449	608	42.7	31.9		
	4.16	421	487	660	41.0	30.6		
	4.57	383	540	732	41.4	30.9		
	5.5	318	583	790	37.2	27.7		
	6.03	290	594	805	34.5	25.8		
	7.39	237	644	872	30.5	22.8		
	8.39	209	677	917	28.3	21.1		
	9.49	184	694	941	25.7	19.1		
	11	159	790	1070	25.2	18.8		
	12.07	145	739	1002	21.5	16.0		
	14.19	123	849	1150	21.0	15.6		
	15.56	112	797	1080	18.0	13.4		
	19.06	92	848	1149	15.6	11.6		
	22.74	77	871	1180	13.4	10.0		
	24.94	70	883	1197	12.4	9.3		
	30.55	57	892	1208	10.2	7.6		
	35.01	50	888	1203	8.9	6.6		
38.4	46	882	1195	8.1	6.0			
47.03	37	832	1128	6.2	4.6			
53.46	33	742	1005	4.9	3.6			
65.48	27	689	934	3.7	2.8			
553	70.22	25	819	1110	4.18	3.1	1.0	213/215 TC
	88.88	20	871	1180	3.51	2.6		
	108.86	16	813	1101	2.67	2.0		
	118.46	15	884	1198	2.67	2.0		182/184 TC
	125.58	14	821	1112	2.34	1.7		
	145.09	12	813	1101	2.01	1.50		
	170.18	10	874	1184	1.84	1.37		
	183.64	10	857	1161	1.67	1.25		
	224.93	8	840	1138	1.34	1.00		
	259.37	7	847	1148	1.17	0.87		143/145 TC
	317.7	6	889	1205	1.00	0.75		





4.8 Technical data

4.8 Datos técnicos

RCV	i	$n_1 = 1750 \text{ min}^{-1}$					FS'	 NEMA	
		n_2 min ⁻¹	Ft-lb	T_2 Nm	Hp	P_1 kW			
582	4.64	377	1043	1413	78.8	58.7	1.0	284/286 TC 254/256 TC 213/215 TC 182/184 TC	
	5.04	347	1086	1471	75.5	56.3			
	6.03	290	1125	1525	65.4	48.8			
	7.38	237	1183	1603	56.2	41.9			
	8.61	203	1277	1731	52.0	38.8			
	9.36	187	1344	1821	50.3	37.5			
	11.2	156	1393	1888	43.6	32.5			
	13.71	128	1410	1911	36.1	26.9			
	15.03	116	1511	2047	35.2	26.3			
	16.34	107	1564	2119	33.5	25.0			
	19.55	90	1544	2092	27.7	20.6			
	23.93	73	1489	2017	21.8	16.3			
	24.99	70	1555	2107	21.8	16.3			
	27.16	64	1625	2202	21.0	15.6			
	30.24	58	1664	2255	19.3	14.4			
	32.5	54	1602	2171	17.3	12.9			
	36.18	48	1584	2146	15.3	11.4			
	39.79	44	1485	2012	13.1	9.8			
44.29	40	1505	2039	11.9	8.9	254/256 TC 213/215 TC 182/184 TC			
583	47.02	37	1491	2021	11.4		8.5	1.0	213/215 TC 182/184 TC 143/145 TC
	56.26	31	1627	2205	10.4		7.7		
	61.71	28	1584	2146	9.2		6.9		
	73.85	24	1633	2213	7.9		5.9		
	90.39	19	1602	2171	6.3		4.7		
	97.71	18	1645	2229	6.0	4.5			
	116.92	15	1640	2222	5.0	3.7			
	139.38	13	1649	2235	4.2	3.2			
	143.12	12	1579	2139	3.9	2.9			
	151.48	12	1652	2239	3.9	2.9			
	181.26	10	1668	2260	3.3	2.5			
	196.86	9	1688	2287	3.1	2.3			
213.94	8	1710	2317	2.9	2.1				
221.87	8	1613	2185	2.6	1.9				
256	7	1739	2356	2.4	1.8				
313.35	6	1639	2221	1.9	1.4				



4.8 Technical data
4.8 Datos técnicos

RCV	i	$n_1 = 1750 \text{ min}^{-1}$					FS'	 NEMA
		n_2 min ⁻¹	Ft·lb	T ₂ Nm	Hp	P ₁ kW		
602	4.64	377	1221	1654	92.2	68.8	1.0	284/286 TC 254/256 TC 213/215 TC 182/184 TC
	5.04	347	1254	1699	87.2	65.0		
	6.03	290	1443	1955	83.9	62.5		
	7.38	237	1731	2345	82.2	61.3		
	8.61	203	1896	2569	77.2	57.6		
	9.36	187	1926	2610	72.1	53.8		
	11.2	156	2165	2933	67.7	50.5		
	13.71	128	2024	2742	51.7	38.6		
	15.03	116	2218	3005	51.7	38.6		
	16.34	107	2314	3135	49.6	37.0		
	19.55	90	2241	3037	40.2	30.0		
	23.93	73	2093	2836	30.7	22.9		
	24.99	70	1757	2381	24.6	18.4		
	27.16	64	1909	2587	24.6	18.4		
	30.24	58	1818	2463	21.1	15.7		
	32.5	54	2285	3096	24.6	18.4		
	36.18	48	2175	2947	21.1	15.7		
	39.79	44	2155	2920	19.0	14.2		
44.29	40	2170	2941	17.2	12.8	1.0	254/256 TC 213/215 TC 182/184 TC	
603	46.6	38	2460	3333	18.9			14.1
	55.8	31	2394	3244	15.4			11.5
	60.1	29	2465	3340	14.7			11.0
	71.9	24	2399	3251	11.9			8.9
	88	20	2255	3055	9.2			6.8
	96.3	18	2476	3355	9.2			6.9
	115.2	15	2409	3264	7.5			5.6
	136.5	13	2464	3339	6.5			4.8
	148.3	12	2484	3366	6.0			4.5
	177.5	10	2443	3310	4.9			3.7
	190.4	9	2479	3359	4.7			3.5
	207	8	2559	3467	4.4	3.3		
	217.2	8	2362	3200	3.9	2.9		
	247.6	7	2542	3444	3.7	2.7		
	303.1	6	2404	3258	2.8	2.1	1.0	182/184 TC





4.9 Dimensions

4.9 Dimensiones

Input flange

Brida entrada

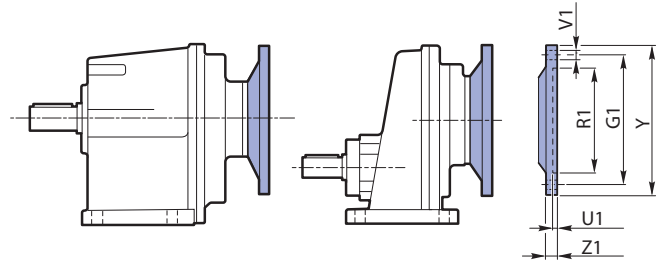

RCV	NEMA	R ₁	G ₁	U ₁	V ₁		Y	Z ₁
					∅			
141	56 C	4 1/2" [114.3]	5 7/8" [149.22]	0.216 [5.5]	0.413 [10.5]	4	6 1/2" [165.1]	0.472 [12]
191	143/145 TC	4 1/2" [114.3]	5 7/8" [149.22]	0.216 [5.5]	0.413 [10.5]	4	6 1/2" [165.1]	0.472 [12]
	56 C							
241	143/145 TC	4 1/2" [114.3]	5 7/8" [149.22]	0.216 [5.5]	0.413 [10.5]	4	6 1/2" [165.1]	0.472 [12]
	56 C							
281	182/184 TC	8 1/2" [215.9]	7 1/4" [184.15]	0.236 [6]	0.551 [14]	4	9 [228.6]	0.590 [15]
	143/145 TC	4 1/2" [114.3]	5 7/8" [149.22]	0.216 [5.5]	0.413 [10.5]	4	6 1/2" [165.1]	0.472 [12]
381	213/215 TC	8 1/2" [215.9]	7 1/4" [184.15]	0.236 [6]	0.551 [14]	4	9 [228.6]	0.590 [15]
	182/184 TC							
	143/145 TC	4 1/2" [114.3]	5 7/8" [149.22]	0.216 [5.5]	0.413 [10.5]	4	6 1/2" [165.1]	0.472 [12]
162	56 C	4 1/2" [114.3]	5 7/8" [149.22]	0.216 [5.5]	0.413 [10.5]	4	6 1/2" [165.1]	0.472 [12]
202A	143/145 TC	4 1/2" [114.3]	5 7/8" [149.22]	0.216 [5.5]	0.413 [10.5]	4	6 1/2" [165.1]	0.472 [12]
	56 C							
202	143/145 TC	4 1/2" [114.3]	5 7/8" [149.22]	0.216 [5.5]	0.413 [10.5]	4	6 1/2" [165.1]	0.472 [12]
	56 C							
203	56 C	4 1/2" [114.3]	5 7/8" [149.22]	0.216 [5.5]	0.413 [10.5]	4	6 1/2" [165.1]	0.472 [12]
252A	143/145 TC	4 1/2" [114.3]	5 7/8" [149.22]	0.216 [5.5]	0.413 [10.5]	4	6 1/2" [165.1]	0.472 [12]
	56 C							
253A	56 C	4 1/2" [114.3]	5 7/8" [149.22]	0.216 [5.5]	0.413 [10.5]	4	6 1/2" [165.1]	0.472 [12]
252	143/145 TC	4 1/2" [114.3]	5 7/8" [149.22]	0.216 [5.5]	0.413 [10.5]	4	6 1/2" [165.1]	0.472 [12]
	56 C							
253	56 C	4 1/2" [114.3]	5 7/8" [149.22]	0.216 [5.5]	0.413 [10.5]	4	6 1/2" [165.1]	0.472 [12]
302	182/184 TC	8 1/2" [215.9]	7 1/4" [184.15]	0.236 [6]	0.551 [14]	4	9 [228.6]	0.590 [15]
	143/145 TC	4 1/2" [114.3]	5 7/8" [149.22]	0.216 [5.5]	0.413 [10.5]	4	6 1/2" [165.1]	0.472 [12]
303	143/145 TC	4 1/2" [114.3]	5 7/8" [149.22]	0.216 [5.5]	0.413 [10.5]	4	6 1/2" [165.1]	0.472 [12]
	56 C							
302A	143/145 TC	4 1/2" [114.3]	5 7/8" [149.22]	0.216 [5.5]	0.413 [10.5]	4	6 1/2" [165.1]	0.472 [12]
	56 C							
303A	143/145 TC	4 1/2" [114.3]	5 7/8" [149.22]	0.216 [5.5]	0.413 [10.5]	4	6 1/2" [165.1]	0.472 [12]
	56 C							

RCV	NEMA	R ₁	G ₁	U ₁	V ₁		Y	Z ₁
					∅			
352	182/184 TC	8 1/2" [215.9]	7 1/4" [184.15]	0.236 [6]	0.551 [14]	4	9 [228.6]	0.590 [15]
	143/145 TC	4 1/2" [114.3]	5 7/8" [149.22]	0.216 [5.5]	0.413 [11]	4	6 1/2" [165.1]	0.472 [12]
353	143/145 TC	4 1/2" [114.3]	5 7/8" [149.22]	0.216 [5.5]	0.413 [10.5]	4	6 1/2" [165.1]	0.472 [12]
	56 C							
452	213/215 TC	8 1/2" [215.9]	7 1/4" [184.15]	0.236 [6]	0.551 [14]	4	9 [228.6]	0.590 [15]
	182/184 TC							
	143/145 TC	4 1/2" [114.3]	5 7/8" [149.22]	0.216 [5.5]	0.413 [11]	4	6 1/2" [165.1]	0.472 [12]
453	182/184 TC	8 1/2" [215.9]	7 1/4" [184.15]	0.236 [6]	0.551 [14]	4	9 [228.6]	0.590 [15]
	143/145 TC	4 1/2" [114.3]	5 7/8" [149.22]	0.216 [5.5]	0.413 [11]	4	6 1/2" [165.1]	0.472 [12]
552	284/286 TC	10 1/2" [266.7]	9 [228.6]	0.236 [6]	0.551 [14]	4	11 1/4" [285.75]	0.669 [17]
	254/256 TC	8 1/2"	7 1/4"	0.236	0.551	4	9	0.590
	213/215 TC							
553	182/184 TC	8 1/2" [215.9]	7 1/4" [184.15]	0.236 [6]	0.551 [14]	4	9 [228.6]	0.590 [15]
	143/145 TC	4 1/2" [114.3]	5 7/8" [149.22]	0.216 [5.5]	0.413 [11]	4	6 1/2" [165.1]	0.472 [12]
	284/286 TC	10 1/2" [266.7]	9 [228.6]	0.236 [6]	0.551 [14]	4	11 1/4" [285.75]	0.669 [17]
582	254/256 TC	8 1/2"	7 1/4"	0.236	0.551	4	9	0.590
	213/215 TC							
	182/184 TC							
583	213/215 TC	8 1/2" [215.9]	7 1/4" [184.15]	0.236 [6]	0.551 [14]	4	9 [228.6]	0.590 [15]
	182/184 TC							
	143/145 TC	4 1/2" [114.3]	5 7/8" [149.22]	0.216 [5.5]	0.413 [11]	4	6 1/2" [165.1]	0.472 [12]
602	284/286 TC	10 1/2" [266.7]	9 [228.6]	0.236 [6]	0.551 [14]	4	11 1/4" [285.75]	0.669 [17]
	254/256 TC	8 1/2"	7 1/4"	0.236	0.551	4	9	0.590
	213/215 TC							
603	254/256 TC	8 1/2"	7 1/4"	0.236	0.551	4	9	0.590
	213/215 TC							
	182/184 TC							



4.9 Dimensions

4.9 Dimensiones

141

P

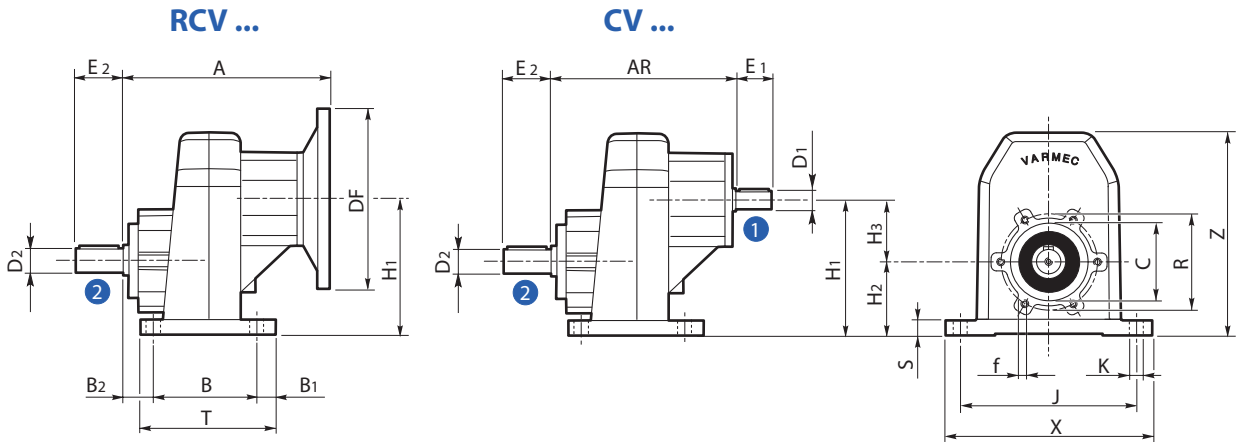

NF

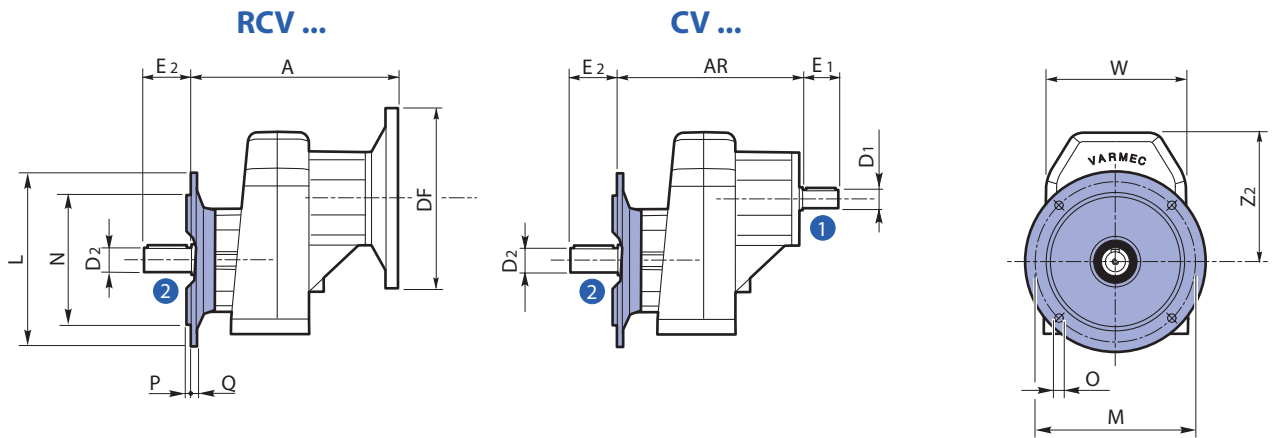

RCV - CV	AR	B	B ₁	B ₂	C h7	f	K	J	H ₁	H ₂	H ₃	R	S	T	W	X	Z	Z ₂	
141	inch [mm]	4.421 [112.3]	2.559 [65]	0.335 [8.5]	0.709 [18]	1.969 [50]	M6	0.354 [9]	4.331 [110]	3.642 [92.51]	1.969 [50]	1.674 [42.51]	2.559 [65]	0.591 [15]	3.228 [82]	3.543 [90]	5.118 [130]	5.472 [139]	3.504 [89]

	L	M	N _{h8}	O	P	Q	
NF120	inch [mm]	4.724 [120]	3.937 [100]	3.150 [80]	0.354 [9]	0.118 [3]	0.354 [9]
NF140	inch [mm]	5.512 [140]	4.528 [115]	3.740 [95]	0.374 [9.5]	0.118 [3]	0.354 [9]
NF160	inch [mm]	6.299 [160]	5.118 [130]	4.331 [110]	0.374 [9.5]	0.138 [3.5]	0.354 [9]

NEMA	A	DF	
56C	inch [mm]	5.295 [134.5]	6.500 [165.1]

1	Input shaft / Eje de entrada							
	D ₁	E ₁	F	G	H	I	U	V
inch [mm]	0.625 [15.875]	1.575 [40.005]	1/4-20	0.630 [16.002]	0.704 [17.882]	0.187 [4.750]	1.000 [25.400]	0.575 [14.605]

2	Output shaft / Eje de salida							
	D ₂	E ₂	F	G	H	I	U	V
inch [mm]	0.625 [15.875]	1.575 [40.005]	1/4-20	0.630 [16.002]	0.704 [17.882]	0.187 [4.750]	1.000 [25.400]	0.575 [14.605]

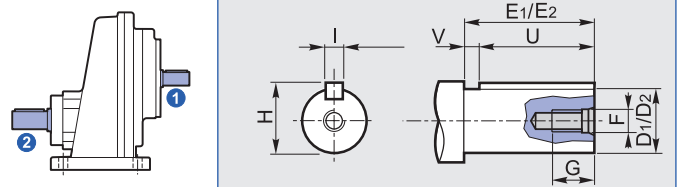



191

P

RCV ...

CV ...

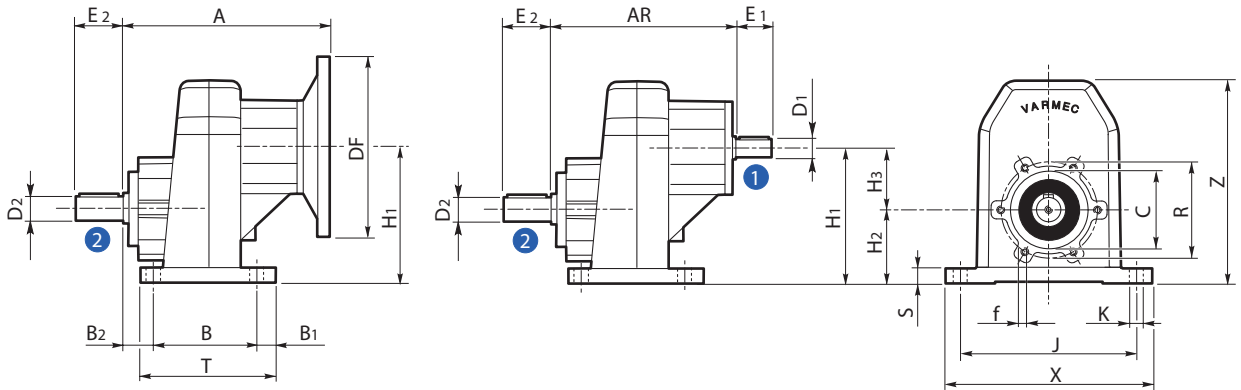

NF

RCV ...

CV ...

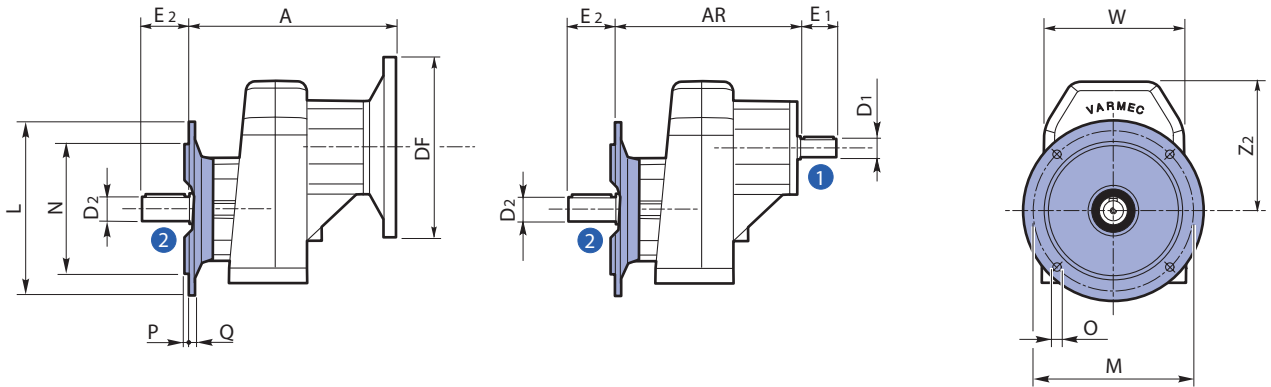

RCV - CV	AR	B	B ₁	B ₂	C h7	f	K	J	H ₁	H ₂	H ₃	R	S	T	W	X	Z	Z ₂	
191	inch [mm]	5.354 - 3.030* [136] - [119.3]*	3.051 [77.5]	0.492 [12.5]	0.748 [19]	2.362 [60]		0.354 [9]	5.118 [130]	4.160 [105.67]	2.165 [55]	1.995 [50.67]	2.953 [75]	0.591 [15]	4.016 [102]	4.409 [112]	5.906 [150]	6.299 [160]	4.134 [105]

	L	M	N h8	O	P	Q	
NF120	inch [mm]	4.724 [120]	3.937 [100]	3.150 [80]	0.354 [9]	0.118 [3]	0.472 [12]
NF140	inch [mm]	5.512 [140]	4.528 [115]	3.740 [95]	0.374 [9.5]	0.118 [3]	0.472 [12]
NF160	inch [mm]	6.299 [160]	5.118 [130]	4.331 [110]	0.374 [9.5]	0.118 [3]	0.472 [12]
NF200	inch [mm]	7.874 [200]	6.496 [165]	5.118 [130]	0.453 [11.5]	0.138 [3.5]	0.472 [12]

NEMA		A	DF
56C	inch	5.906	6.500
	[mm]	[150]	[165.1]
143/145TC	inch	5.906	6.500
	[mm]	[150]	[165.1]

1	Input shaft / Eje de entrada							
	D ₁	E ₁	F	G	H	I	U	V
inch [mm]	0.75 [19.050]	1.575 [40.005]	5/16-18	0.709 [18.009]	0.832 [21.133]	0.187 [4.750]	1.000 [25.400]	0.575 [14.605]

2	Output shaft / Eje de salida							
	D ₂	E ₂	F	G	H	I	U	V
inch [mm]	0.75 [19.050]	1.575 [40.005]	5/16-18	0.709 [18.009]	0.832 [21.133]	0.187 [4.750]	1.000 [25.400]	0.575 [14.605]

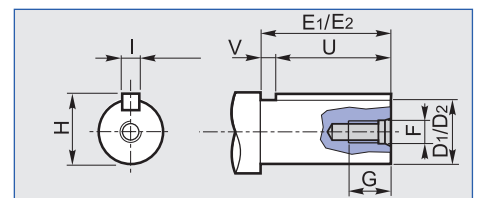
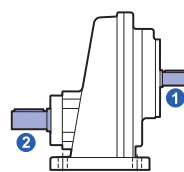



241

P

RCV ...

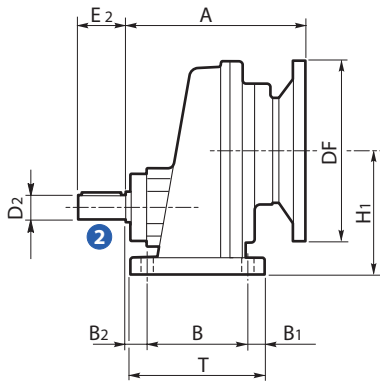

CV ...

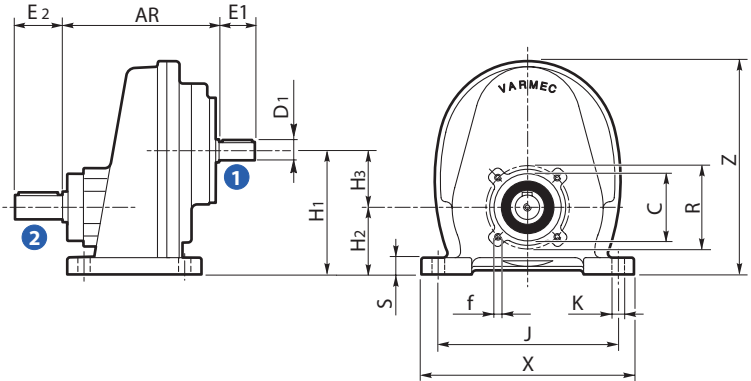

NF

RCV ...

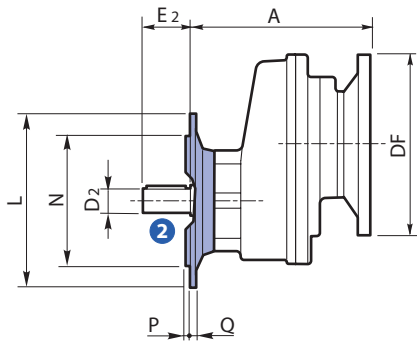

CV ...

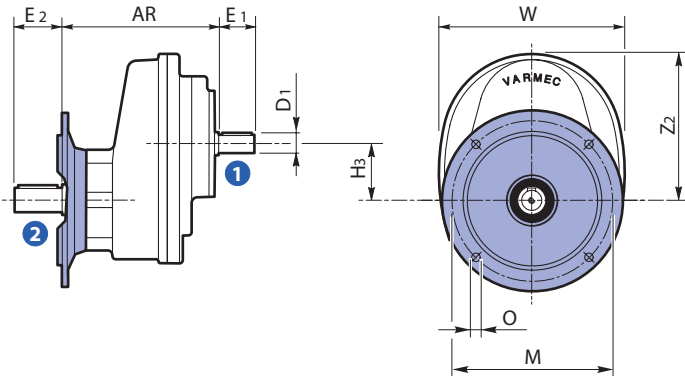

RCV - CV	AR	B	B ₁	B ₂	C h7	f	K	J	H ₁	H ₂	H ₃	R	S	T	W	X	Z	Z ₂	
241	inch [mm]	5.669 [144]	3.543 [90]	0.591 [15]	0.709 [18]	2.362 [60]	M6	0.433 [11]	6.299 [160]	4.354 [110.6]	2.362 [60]	1.992 [50.6]	2.953 [75]	0.591 [15]	4.921 [125]	6.535 [166]	7.480 [190]	7.480 [190]	5.118 [130]

	L	M	N h8	O	P	Q	
NF120	inch [mm]	4.724 [120]	3.937 [100]	3.150 [80]	0.276 [7]	0.098 [2.5]	0.394 [10]
NF140	inch [mm]	5.512 [140]	4.528 [115]	3.740 [95]	0.354 [9]	0.118 [3]	0.394 [10]
NF160	inch [mm]	6.299 [160]	5.118 [130]	4.331 [110]	0.433 [11]	0.118 [3]	0.394 [10]
NF200	inch [mm]	7.874 [200]	6.496 [165]	5.118 [130]	0.433 [11]	0.118 [3]	0.394 [10]

NEMA		A	DF
56C	inch	6.220	6.500
	[mm]	[158]	[165.1]
143/145TC	inch	6.220	6.500
	[mm]	[158]	[165.1]

1 **Input shaft / Eje de entrada**

	D ₁	E ₁	F	G	H	I	U	V
inch [mm]	0.75 [19.050]	1.575 [40.005]	5/16-18	0.709 [18.009]	0.832 [21.133]	0.187 [4.750]	1.000 [25.400]	0.575 [14.605]

2 **Output shaft / Eje de salida**

	D ₂	E ₂	F	G	H	I	U	V
inch [mm]	0.75 [19.050]	1.575 [40.005]	5/16-18	0.709 [18.009]	0.832 [21.133]	0.187 [4.750]	1.000 [25.400]	0.575 [14.605]
inch [mm]	1.000 [25.400]	1.969 [50.012]	5/16-18	0.709 [18.009]	1.109 [28.168]	0.25 [6.350]	1.500 [38.100]	0.469 [11.913]

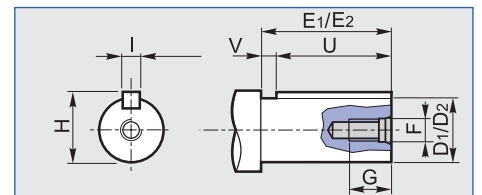
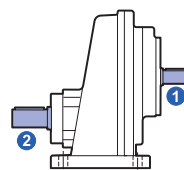



281

P

RCV ...

CV ...

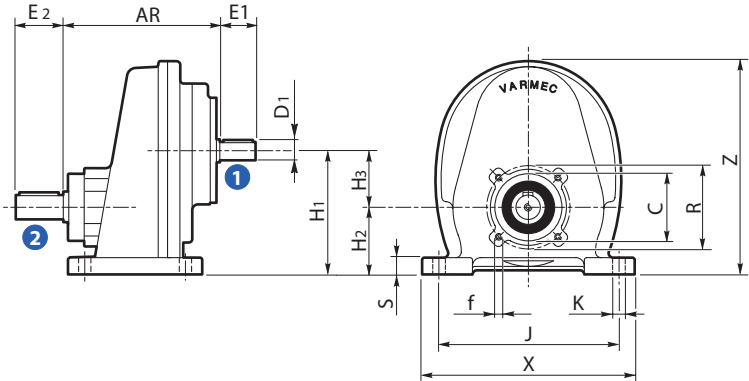
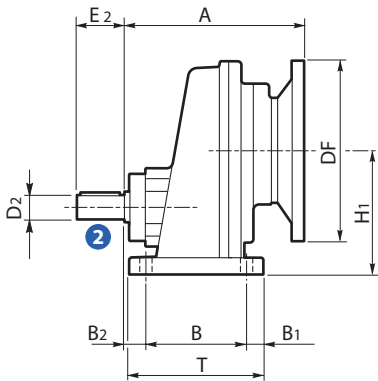

NF

RCV ...

CV ...

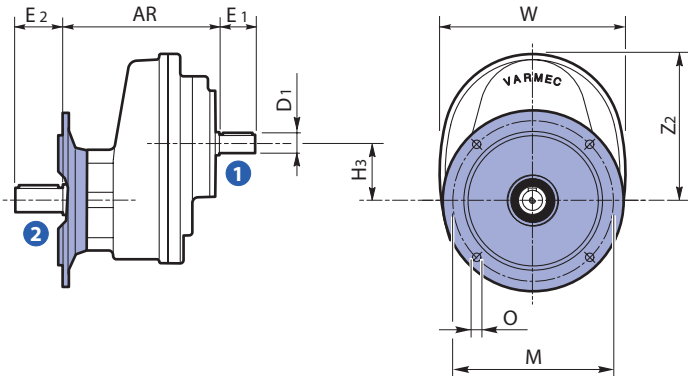
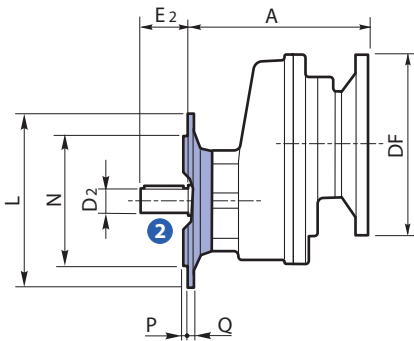

RCV - CV	AR	B	B ₁	B ₂	C h7	f	K	J	H ₁	H ₂	H ₃	R	S	T	W	X	Z	Z ₂	
281	inch [mm]	7.480 [190]	4.921 [125]	0.787 [20]	0.787 [20]	3.150 [80]	M10	0.551 [14]	7.087 [180]	5.134 [130.4]	2.756 [70]	2.378 [60.4]	3.937 [100]	0.630 [16]	6.457 [164]	7.677 [195]	8.465 [215]	8.780 [223]	6.024 [153]

	L	M	N h8	O	P	Q	
NF160	inch [mm]	6.299 [160]	5.118 [130]	4.331 [110]	0.433 [11]	0.138 [3.5]	0.433 [11]
NF200	inch [mm]	7.874 [200]	6.496 [165]	5.118 [130]	0.512 [13]	0.138 [3.5]	0.433 [11]
NF250	inch [mm]	9.843 [250]	8.465 [215]	7.087 [180]	0.551 [14]	0.157 [4]	0.512 [13]

NEMA	A	DF	
143/145TC	inch [mm]	8.071 [205]	6.500 [165.1]
182/184TC	inch [mm]	8.307 [211]	9.000 [228.6]

1	Input shaft / Eje de entrada							
	D ₁	E ₁	F	G	H	I	U	V
inch [mm]	1.000 [25.400]	1.969 [50.012]	5/16-16	0.709 [18.009]	1.109 [28.168]	0.250 [6.350]	1.500 [38.100]	0.469 [11.913]

2	Output shaft / Eje de salida							
	D ₂	E ₂	F	G	H	I	U	V
inch [mm]	1.125 [28.575]	2.362 [59.994]	3/8-16	0.906 [23.012]	1.236 [31.394]	0.25 [6.350]	1.750 [44.450]	0.612 [15.545]

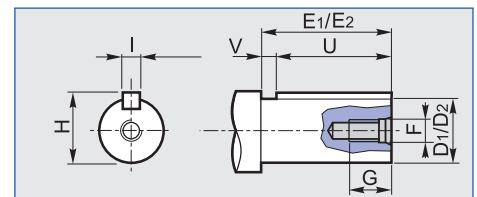
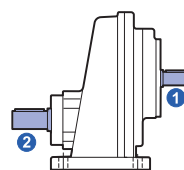



381

P

RCV ...

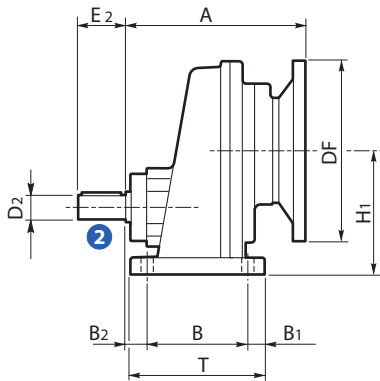

CV ...

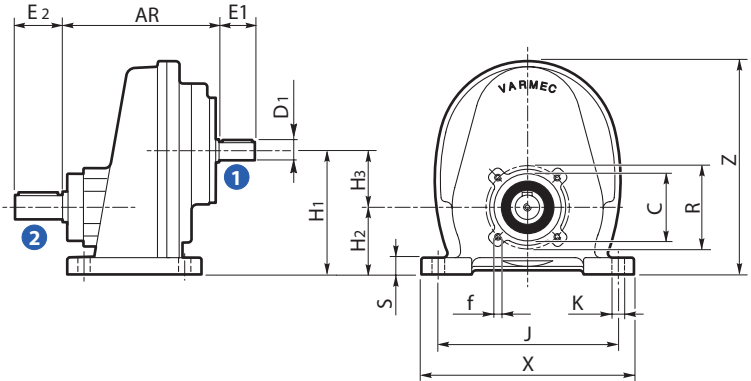

NF

RCV ...

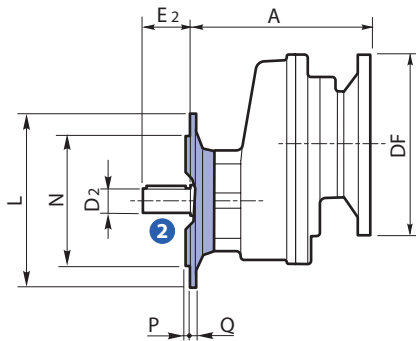

CV ...

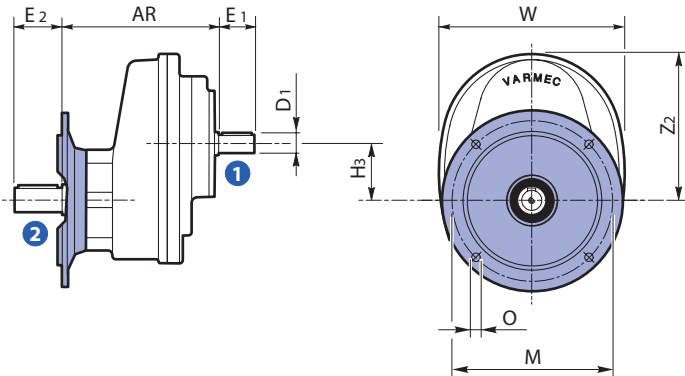

RCV - CV	AR	B	B ₁	B ₂	C h7	f	K	J	H ₁	H ₂	H ₃	R	S	T	W	X	Z	Z ₂	
381	inch [mm]	8.504 [216]	5.709 [145]	0.984 [25]	0.984 [25]	4.331 [110]	M10	0.709 [18]	8.858 [225]	6.102 [155]	3.228 [82]	2.874 [73]	5.118 [130]	0.709 [18]	7.480 [190]	9.055 [230]	10.630 [270]	10.433 [265]	7.205 [183]

		L	M	N _{h8}	O	P	Q
NF200	inch [mm]	11.811 [300]	6.496 [165]	5.118 [130]	0.551 [14]	0.157 [4]	0.551 [14]
NF250	inch [mm]	9.843 [250]	8.465 [215]	7.087 [180]	0.551 [14]	0.157 [4]	0.551 [14]
NF300	inch [mm]	11.811 [300]	10.433 [265]	9.055 [230]	0.551 [14]	0.157 [4]	0.551 [14]

NEMA	A	DF	
143/145TC	inch [mm]	9.331 [237]	6.500 [165.1]
182/184TC	inch [mm]	9.567 [243]	9.000 [228.6]
213/215TC	inch [mm]	9.567 [243]	9.000 [228.6]

1 **Input shaft / Eje de entrada**

	D ₁	E ₁	F	G	H	I	U	V
inch [mm]	1.125 [28.575]	2.362 [59.994]	5/16-18	0.709 [18.009]	1.236 [31.394]	0.250 [6.350]	1.750 [44.450]	0.612 [15.545]

2 **Output shaft / Eje de salida**

	D ₂	E ₂	F	G	H	I	U	V
inch [mm]	1.625 [41.275]	3.150 [80.010]	1/2-13	1.299 [32.994]	1.792 [45.516]	0.375 [9.525]	2.500 [63.500]	0.650 [16.510]

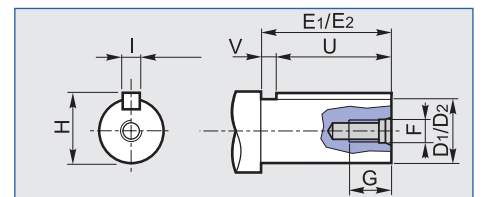
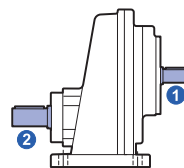



162

RCV ...

CV ...

P

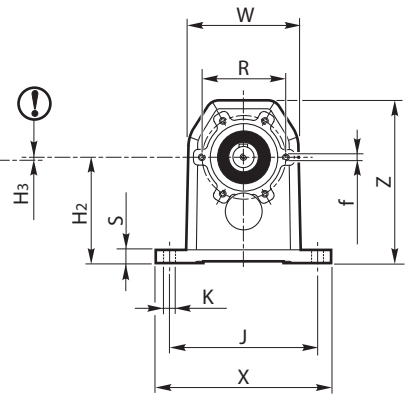
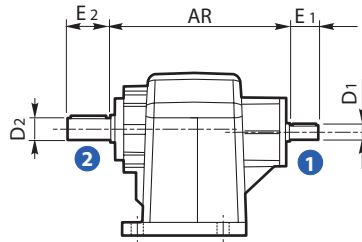
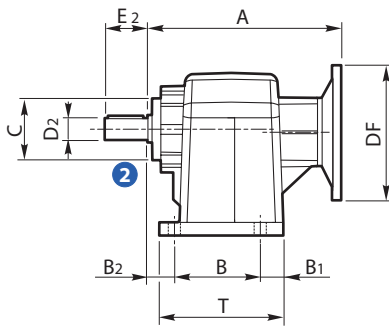

RCV ...

CV ...

NF

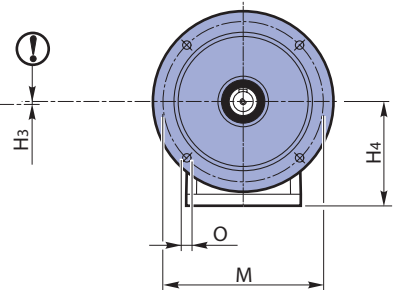
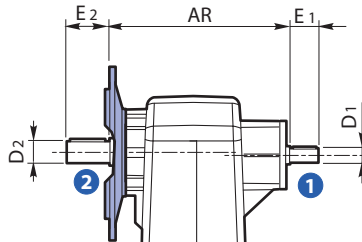
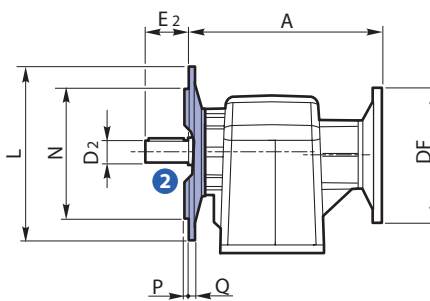

RCV - CV	AR	B	B ₁	B ₂	C h7	f	K	J	H ₂	H ₃	H ₄	R	S	T	W	X	Z	
162	inch [mm]	5.425 [137.8]	1.969 [50]	1.260 [32]	0.709 [18]	1.969 [50]	M6	0.354 [9]	4.331 [110]	3.346 [85]	0.092 [2.34]	3.071 [78]	2.559 [65]	0.413 [10.5]	3.626 [92.1]	3.228 [82]	5.118 [130]	5.118 [130]

	L	M	N _{h8}	O	P	Q	
NF120	inch [mm]	4.724 [120]	3.937 [100]	3.150 [80]	0.354 [9]	0.118 [3]	0.354 [9]
NF140	inch [mm]	5.512 [140]	4.528 [115]	3.740 [95]	0.374 [9.5]	0.118 [3]	0.354 [9]
NF160	inch [mm]	6.299 [160]	5.118 [130]	4.331 [110]	0.374 [9.5]	0.138 [3.5]	0.354 [9]

NEMA	A	DF	
56C	inch [mm]	6.300 [160]	6.500 [165.1]

1	Input shaft / Eje de entrada							
	D ₁	E ₁	F	G	H	I	U	V
inch [mm]	0.625 [15.875]	1.575 [40.005]	1/4-20	0.630 [16.002]	0.704 [17.882]	0.187 [4.750]	1.000 [25.400]	0.575 [14.605]

2	Output shaft / Eje de salida							
	D ₂	E ₂	F	G	H	I	U	V
inch [mm]	0.625 [15.875]	1.575 [40.005]	1/4-20	0.630 [16.002]	0.704 [17.882]	0.187 [4.750]	1.000 [25.400]	0.575 [14.605]

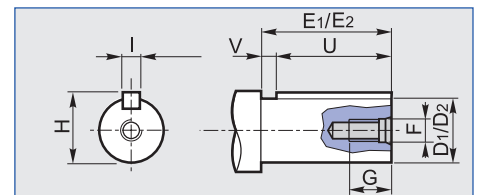
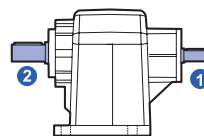



4.9 Dimensions

4.9 Dimensiones

202A

RCV ...

CV ...

P-B

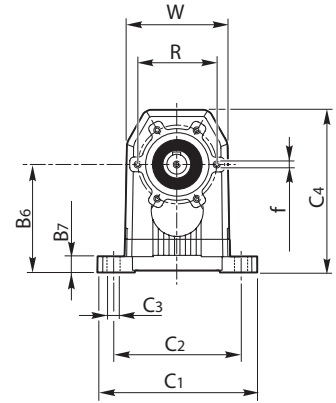
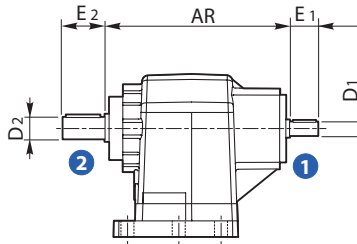
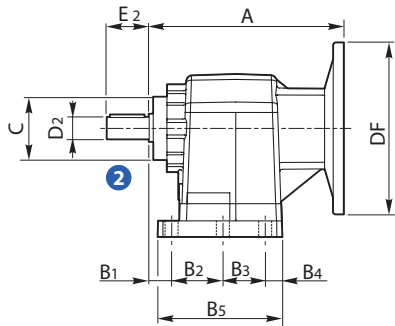

NF

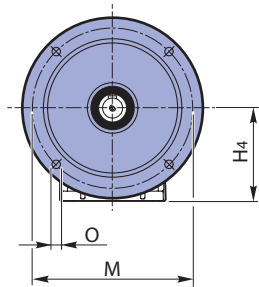
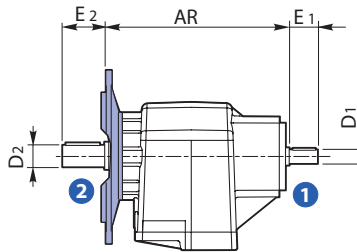
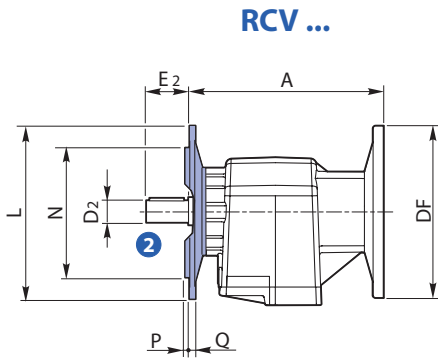

RCV - CV		AR	B1	B2	B3	B4	B5	B6	B7	C _{h7}	C1	C2	C3	C4	f	H4	R	W	
202A	P	inch [mm]	6.811 - 6.173*	0.709 [18]	2.362 [60]	1.181 [30]	0.571 [14.5]	4.587 [116.5]	3.937 [100]	0.591 [15]	2.362 [60]	5.906 [150]	5.118 [130]	0.433 [11]	5.925 [150.5]	M6 [87]	3.425 [75]	2.953 [75]	3.701 [94]
	B	inch [mm]	[173] - [156.8]*	0.709 [18]	1.969 [50]	1.457 [37]	0.630 [16]	4.469 [113.5]	3.346 [85]	0.591 [15]		5.118 [130]	4.331 [110]	0.354 [9]	5.335 [135.5]				

	L	M	N _{h8}	O	P	Q	
NF120	inch [mm]	4.724 [120]	3.937 [100]	3.150 [80]	0.354 [9]	0.118 [3]	0.472 [12]
NF140	inch [mm]	5.512 [140]	4.528 [115]	3.740 [95]	0.374 [9.5]	0.118 [3]	0.472 [12]
NF160	inch [mm]	6.299 [160]	5.118 [130]	4.331 [110]	0.374 [9.5]	0.118 [3]	0.472 [12]
NF200	inch [mm]	7.874 [200]	6.496 [165]	5.118 [130]	0.453 [11.5]	0.138 [3.5]	0.472 [12]

NEMA		A	DF
56C	inch	7.402	6.500
	[mm]	[188]	[165.1]
143/145TC	inch	7.402	6.500
	[mm]	[188]	[165.1]

1 Input shaft / Eje de entrada

	D ₁	E ₁	F	G	H	I	U	V
inch [mm]	0.750 [19.050]	1.575 [40.005]	5/16-18	0.709 [18.009]	0.832 [21.133]	0.187 [4.750]	1.000 [25.400]	0.575 [14.605]

2 Output shaft / Eje de salida

	D ₂	E ₂	F	G	H	I	U	V
inch [mm]	0.750 [19.050]	1.575 [40.005]	5/16-18	0.708 [17.983]	0.832 [21.133]	0.187 [4.750]	1.000 [25.400]	0.575 [14.605]

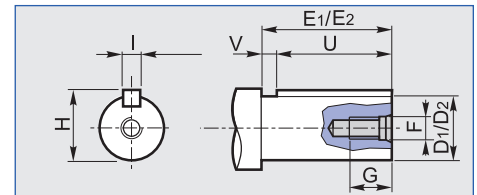
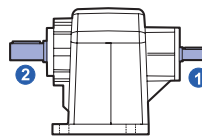



202-203

RCV ...

CV ...

P

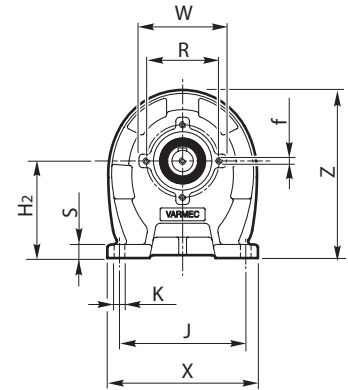
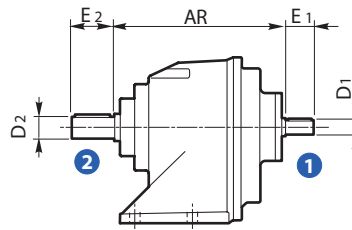
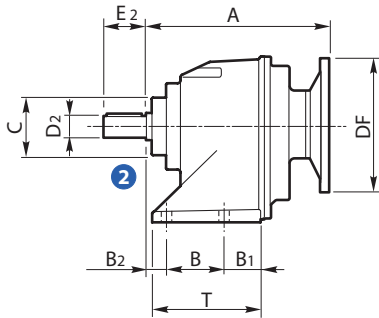

NF

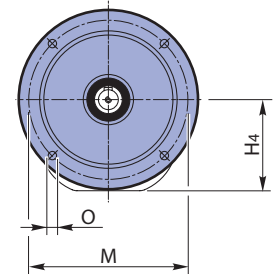
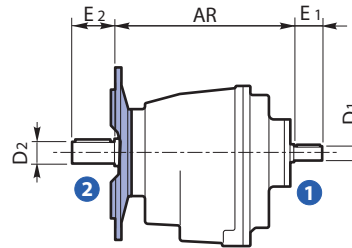
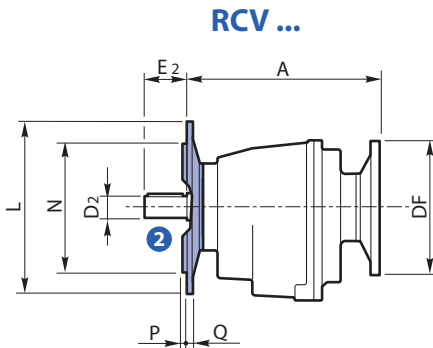

RCV - CV		AR	B	B ₁	B ₂	C h7	f	K	J	H ₂	H ₄	R	S	T	W	X	Z
202	inch	6.811 [173]	2.362	1.496	0.709	2.362		0.433	5.118	3.937	3.819	2.953	0.551	4.291	3.543	6.102	6.811
203	[mm]	6.693 [170]	[60]	[38]	[18]	[60]	M6	[11]	[130]	[100]	[97]	[75]	[14]	[109]	[90]	[155]	[173]

		L	M	N _{h8}	O	P	Q
NF120	inch	4.724	3.937	3.150	0.276	0.098	0.394
	[mm]	[120]	[100]	[80]	[7]	[2.5]	[10]
NF140	inch	5.512	4.528	3.740	0.354	0.118	0.394
	[mm]	[140]	[115]	[95]	[9]	[3]	[10]
NF160	inch	6.299	5.118	4.331	0.433	0.118	0.394
	[mm]	[160]	[130]	[110]	[11]	[3]	[10]
NF200	inch	7.874	6.496	5.118	0.433	0.118	0.394
	[mm]	[200]	[165]	[130]	[11]	[3]	[10]

NEMA			A	DF
202	56C	inch	7.402	6.500
		[mm]	[188]	[165.1]
203	56C	inch	7.567	6.500
		[mm]	[192.2]	[165.1]

1		Input shaft / Eje de entrada							
		D ₁	E ₁	F	G	H	I	U	V
202	inch	0.750	1.575	5/16-18	0.709	0.832	0.187	1.000	0.575
	[mm]	[19.05]	[40.005]		[18]	[21.133]	[4.750]	[25.400]	[14.605]
203	inch	0.625	1.575	1/4-20	0.630	0.704	0.187	1.000	0.575
	[mm]	[15.875]	[40.005]		[16]	[17.882]	[4.750]	[25.400]	[14.605]

2		Output shaft / Eje de salida							
		D ₂	E ₂	F	G	H	I	U	V
202	inch	0.750	1.575	5/16-18	0.709	0.832	0.187	1.000	0.575
	[mm]	[19.05]	[40.005]		[18]	[21.133]	[4.750]	[25.400]	[14.605]
203	inch	0.750	1.575	5/16-18	0.709	0.832	0.187	1.000	0.575
	[mm]	[19.05]	[40.005]		[18]	[21.133]	[4.750]	[25.400]	[14.605]

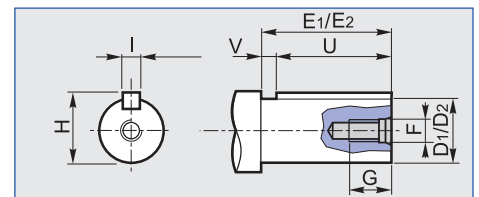
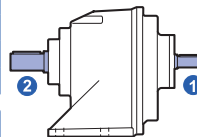



4.9 Dimensions

4.9 Dimensiones

252A - 253A

P-B

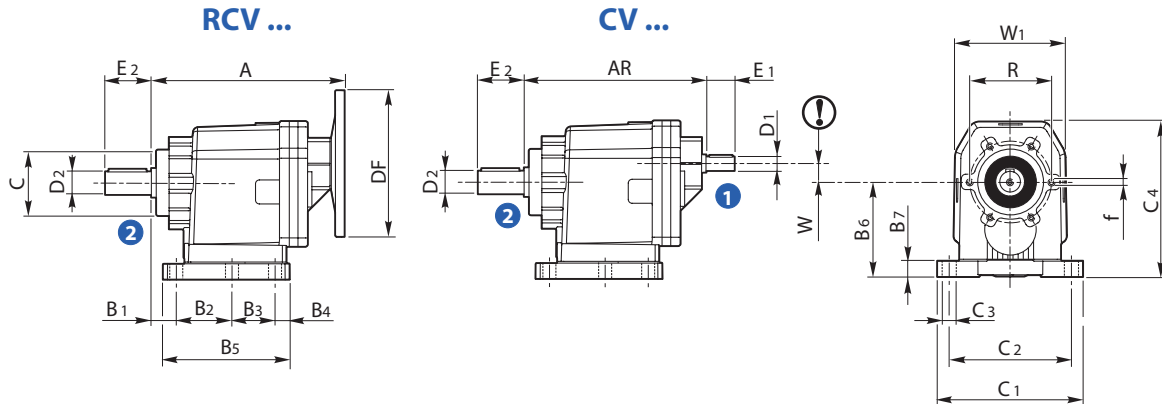

NF

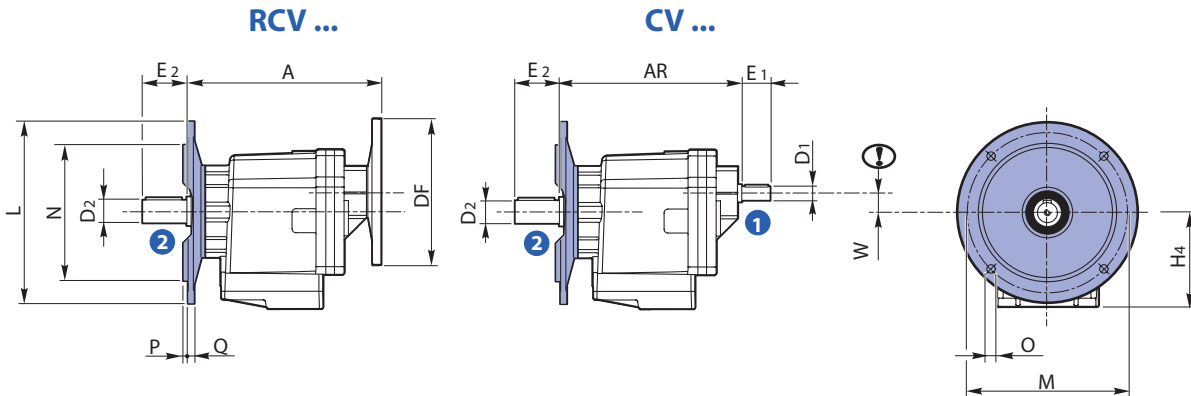

RCV - CV			AR	B1	B2	B3	B4	B5	B6	B7	C h7	C1	C2	C3	C4	f	H4	R	W	W1
252A	P	inch	7.402	0.709	2.756	1.575	0.551	5.354	4.331	0.669	2.756	7.283	6.299	0.433	6.890	M8	4.094	2.953	0.000	4.803
		[mm]	[188]	[18]	[70]	[40]	[14]	[136]	[110]	[17]		[185]	[160]	[11]	[175]				[0]	
253A	B	inch	7.343	0.709	2.362	1.870	0.591	5.315	3.937	0.669	[70]	6.102	5.118	0.433	6.496	[104]	[75]	0.787	[122]	
		[mm]	[186.5]	[18]	[60]	[47.5]	[15]	[135]	[100]	[17]		[155]	[130]	[11]	[165]			[20]		

	L	M	N h8	O	P	Q	
NF140	inch [mm]	5.512 [140]	4.528 [115]	3.740 [95]	0.374 [9.5]	0.118 [3]	0.472 [12]
NF160	inch [mm]	6.299 [160]	5.118 [130]	4.331 [110]	0.374 [9.5]	0.118 [3]	0.472 [12]
NF200	inch [mm]	7.874 [200]	6.496 [165]	5.118 [130]	0.453 [11.5]	0.138 [3.5]	0.472 [12]

NEMA			A	DF
252A	56C	inch [mm]	7.972 [202.5]	6.500 [165.1]
	143/145TC	inch [mm]	7.972 [202.5]	6.500 [165.1]
253A	56C	inch [mm]	8.228 [209]	6.500 [165.1]

1 Input shaft / Eje de entrada

	D ₁	E ₁	F	G	H	I	U	V	
252A	inch [mm]	0.750 [19.05]	1.575 [40.005]	5/16-18	0.709 [18]	0.832 [21.133]	0.187 [4.750]	1.000 [25.400]	0.575 [14.605]
253A	inch [mm]	0.625 [15.875]	1.575 [40.005]	1/4-20	0.630 [16]	0.704 [17.882]	0.187 [4.750]	1.000 [25.400]	0.575 [14.605]

2 Output shaft / Eje de salida

	D ₂	E ₂	F	G	H	I	U	V	
252A	inch [mm]	1.000 [25.400]	1.969 [50.012]	5/16-18	0.709 [18]	1.109 [28.168]	0.250 [6.350]	1.500 [38.100]	0.469 [11.913]
253A	inch [mm]	1.000 [25.400]	1.969 [50.012]	5/16-18	0.709 [18]	1.109 [28.168]	0.250 [6.350]	1.500 [38.100]	0.469 [11.913]

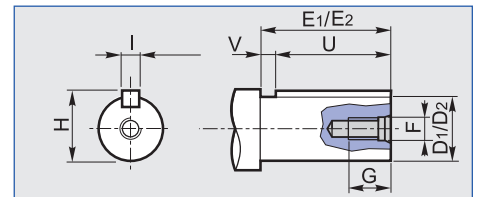
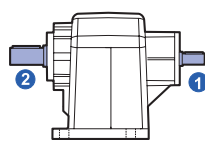



252 - 253

P

RCV ...

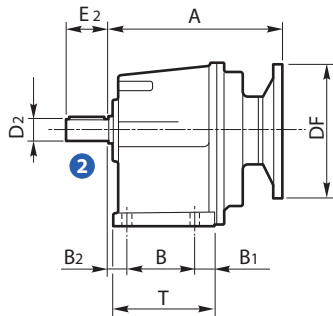

CV ...

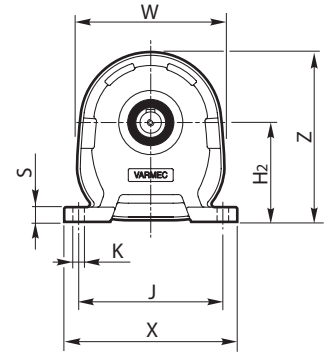
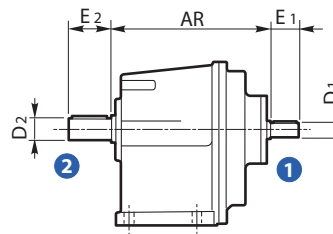

NF

RCV ...

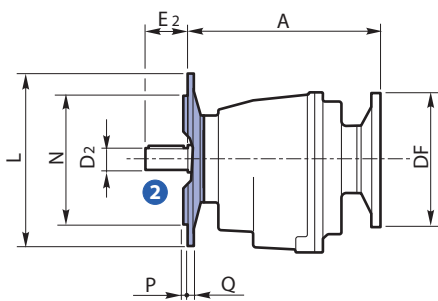

CV ...

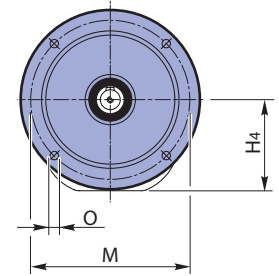
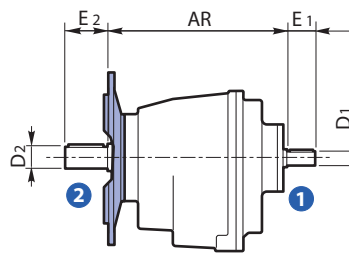

RCV - CV		AR		B	B1	B2	K	J	H2	H4	S	T	W	X	Z
		P	NF												
252	inch	6.378 [162]	7.362 [187]	2.756	0.787	0.709	0.433	6.299	4.331	4.212	0.630	4.134	6.535	7.480	7.480
253	[mm]	6.283 [159.6]	7.268 [184.6]	[70]	[20]	[18]	[11]	[160]	[110]	[107]	[16]	[105]	[166]	[190]	[190]

		L	M	N h8	O	P	Q
NF140	inch	5.512	4.528	3.740	0.354	0.118	0.394
	[mm]	[140]	[115]	[95]	[9]	[3]	[10]
NF160	inch	6.299	5.118	4.331	0.433	0.118	0.394
	[mm]	[160]	[130]	[110]	[11]	[3]	[10]
NF200	inch	7.874	6.496	5.118	0.453	0.138	0.394
	[mm]	[200]	[165]	[130]	[11.5]	[3.5]	[10]

NEMA		A		DF	
		P	NF		
252	56C	inch [mm]	6.969 [177]	7.953 [202]	6.500 [165.1]
	143/145TC	inch [mm]	6.969 [177]	7.953 [202]	6.500 [165.1]
253	56C	inch [mm]	7.154 [181.7]	8.138 [206.7]	6.500 [165.1]

1		Input shaft / Eje de entrada							
		D ₁	E ₁	F	G	H	I	U	V
252	inch	0.750	1.575	5/16-18	0.709	0.832	0.187	1.000	0.575
	[mm]	[19.05]	[40.005]		[18]	[21.133]	[4.750]	[25.400]	[14.605]
253	inch	0.625	1.575	1/4-20	0.630	0.704	0.187	1.000	0.575
	[mm]	[15.875]	[40.005]		[16]	[17.882]	[4.750]	[25.400]	[14.605]

2		Output shaft / Eje de salida							
		D ₂	E ₂	F	G	H	I	U	V
252	inch	1.000	1.969	5/16-18	0.709	1.109	0.250	1.500	0.469
	[mm]	[25.400]	[50.012]		[18]	[28.168]	[6.350]	[38.100]	[11.913]
253	inch	1.000	1.969	5/16-18	0.709	1.109	0.250	1.500	0.469
	[mm]	[25.400]	[50.012]		[18]	[28.168]	[6.350]	[38.100]	[11.913]

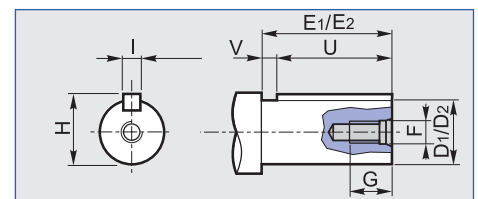
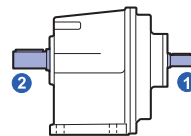



4.9 Dimensions

4.9 Dimensiones

302 - 303

P

RCV ...

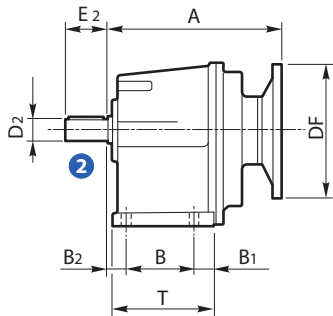

CV ...

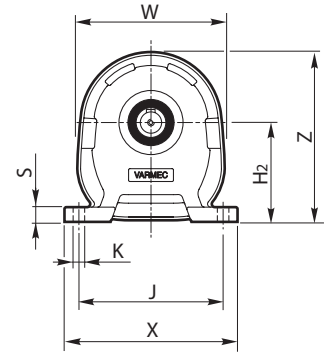
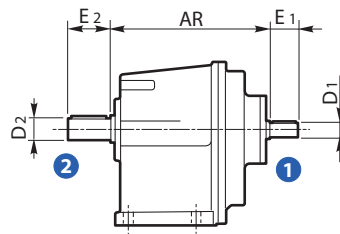

NF

RCV ...

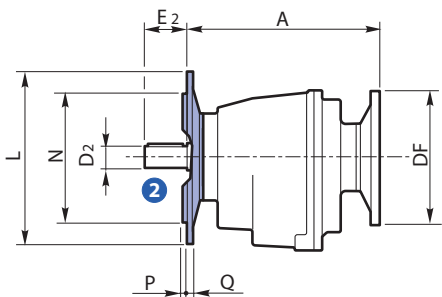

CV ...

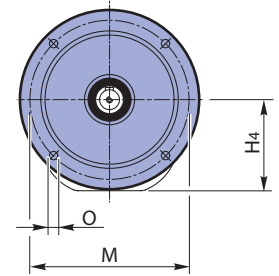
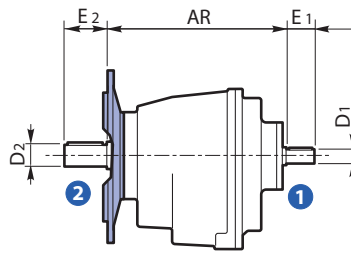

RCV - CV	AR		B	B1	B2	K	J	H2	H4	S	T	W	X	Z	
	P	NF													
302	inch	8.622 [219]	9.606 [244]	4.134	0.827	0.787	0.551	7.087	5.118	5.079	0.709	5.630	7.677	8.465	8.661
303	[mm]	8.425 [214]	9.409 [239]	[105]	[21]	[20]	[14]	[180]	[130]	[129]	[18]	[143]	[195]	[215]	[220]

		L	M	N h8	O	P	Q
NF160	inch	6.299	5.118	4.330	0.433	0.137	0.433
	[mm]	[160]	[130]	[110]	[11]	[3.5]	[11]
NF200	inch	7.874	6.496	5.118	0.512	0.137	0.433
	[mm]	[200]	[165]	[130]	[13]	[3.5]	[11]
NF250	inch	9.842	8.464	7.086	0.551	0.157	0.433
	[mm]	[250]	[215]	[180]	[14]	[4]	[11]

NEMA		A		DF	
		P	NF		
302	143/145TC	inch	9.213 [234]	10.197 [259]	6.500 [165.1]
	182/184TC	inch	9.449 [240]	10.433 [265]	9.000 [228.6]
303	56C	inch	9.016 [229]	10.000 [254]	6.500 [165.1]
	143/145TC	inch	9.016 [229]	10.000 [254]	6.500 [165.1]

1		Input shaft / Eje de entrada							
		D ₁	E ₁	F	G	H	I	U	V
302	inch	1.000	1.969	5/16-18	0.709	1.109	0.250	1.500	0.469
	[mm]	[25.400]	[50.012]		[18.009]	[28.168]	[6.350]	[38.100]	[11.913]
303	inch	0.750	1.575	5/16-18	0.709	0.832	0.187	1.000	0.575
	[mm]	[19.050]	[40.005]		[18.009]	[21.133]	[4.750]	[25.400]	[14.605]

2		Output shaft / Eje de salida							
		D ₂	E ₂	F	G	H	I	U	V
302	inch	1.187	2.362	3/8-16	0.906	1.299	0.250	1.750	0.612
	[mm]	[30.149]	[59.994]		[23.012]	[32.994]	[6.350]	[44.450]	[15.545]
303	inch	1.187	2.362	3/8-16	0.906	1.299	0.250	1.750	0.612
	[mm]	[30.149]	[59.994]		[23.012]	[32.994]	[6.350]	[44.450]	[15.545]

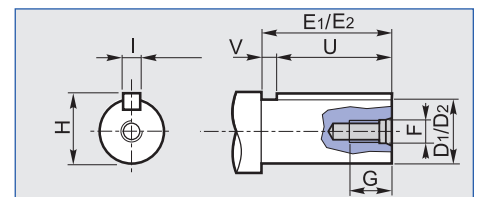
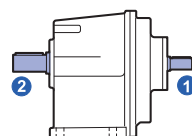



302A - 303A

P-B

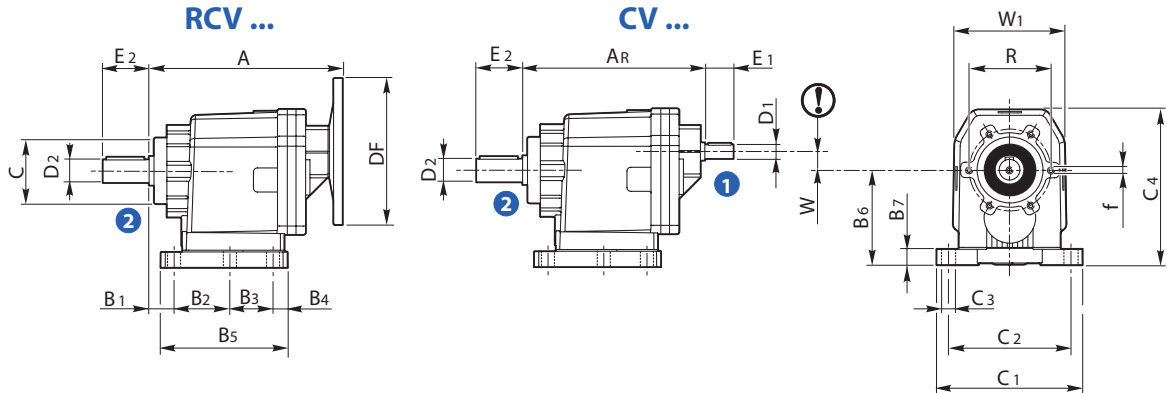

NF

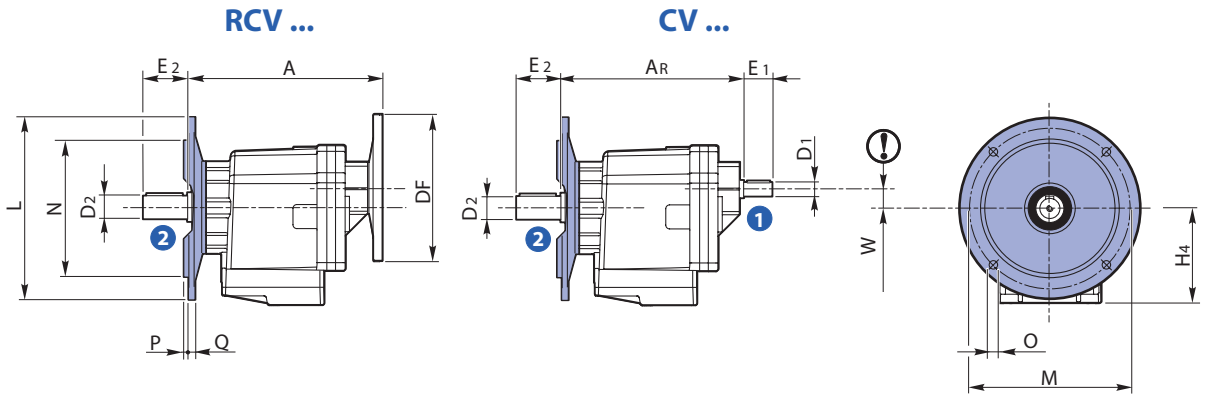

RCV - CV		B1	B2	B3	B4	B5	B6	B7	C h7	C1	C2	C3	C4	H4	f	R	W	W1	
302A	P	inch [mm]	0.787 [20]	4.134 [105]	1.752 [44.5]	0.669 [17]	7.244 [184]	5.118 [130]	0.787 [20]	3.346 [210]	8.268 [180]	7.087 [14]	0.551 [202]	7.953	4.469 [113.5]	M8	3.937 [100]	0.236 [6]	5.866 [149]
	B	inch [mm]	0.709 [18]	2.756 [70]	2.362 [60]	1.535 [39]	7.205 [183]	4.331 [110]	0.787 [20]	[85]	7.323 [186]	6.299 [160]	0.433 [11]	7.283 [185]				0.866 [22]	

		L	M	N h8	O	P	Q
NF160	inch [mm]	6.299 [160]	5.118 [130]	4.331 [110]	0.374 [9.5]	0.118 [3]	0.472 [12]
NF200	inch [mm]	7.874 [200]	6.496 [165]	5.118 [130]	0.453 [11.5]	0.138 [3.5]	0.472 [12]
NF250	inch [mm]	9.843 [250]	8.465 [215]	7.087 [180]	0.551 [14]	0.157 [4]	0.551 [14]

	CV	AR
302A	inch [mm]	9.744-8.976* [247.5] - [228]*
303A	inch [mm]	9.547 [242.5]

		NEMA		A	DF
302A	56C	inch [mm]	9.528 [242]	6.500 [165.1]	
	143/145TC	inch [mm]	9.528 [242]	6.500 [165.1]	
303A	56C	inch [mm]	10.000 [254]	6.500 [165.1]	
	143/145TC	inch [mm]	10.000 [254]	6.500 [165.1]	

1		Input shaft / Eje de entrada							
		D ₁	E ₁	F	G	H	I	U	V
302A	inch [mm]	1.000 [25.400]	1.969 [50.012]	5/16-18	0.709 [18.009]	1.109 [28.168]	0.250 [6.350]	1.500 [38.100]	0.469 [11.913]
303A	inch [mm]	0.750 [19.050]	1.575 [40.005]	5/16-18	0.709 [18.009]	0.832 [21.133]	0.187 [4.750]	1.000 [25.400]	0.575 [14.605]

2		Output shaft / Eje de salida							
		D ₂	E ₂	F	G	H	I	U	V
302A	inch [mm]	1.187 [30.149]	2.362 [59.994]	3/8-16	0.906 [23.012]	1.299 [32.994]	0.250 [6.350]	1.750 [44.450]	0.612 [15.545]
303A	inch [mm]	1.187 [30.149]	2.362 [59.994]	3/8-16	0.906 [23.012]	1.299 [32.994]	0.250 [6.350]	1.750 [44.450]	0.612 [15.545]

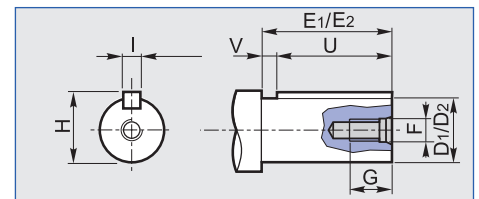
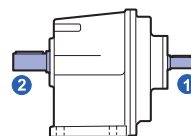



4.9 Dimensions

4.9 Dimensiones

352 - 353

P

RVC ...

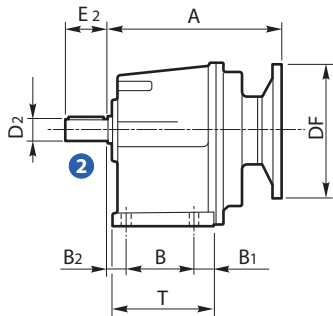

CV ...

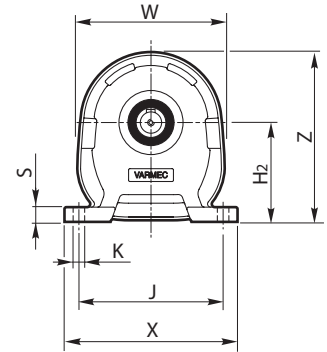
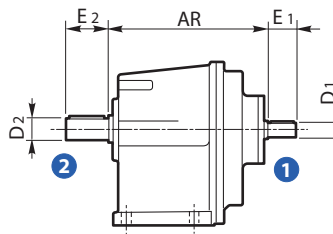

NF

RVC ...

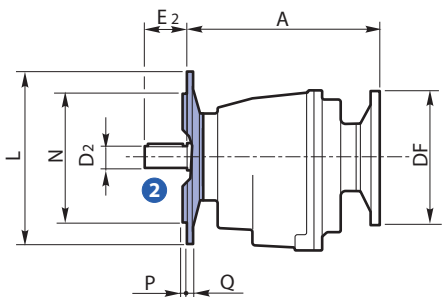

CV ...

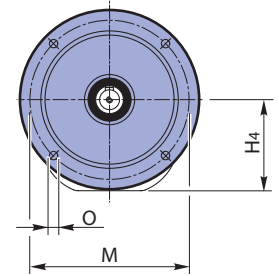
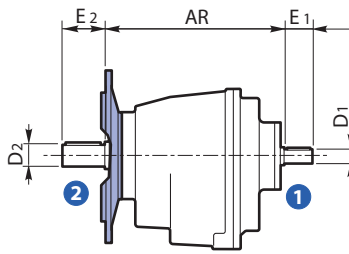

RVC	AR		B	B ₁	B ₂	K	J	H ₂	H ₄	S	T	W	X	Z	
	P	NF													
352	inch	8.622 [219]	9.606 [244]	4.134	0.827	0.787	0.551	7.087	5.118	5.078	0.709	5.630	7.677	8.464	8.661
353	[mm]	8.425 [214]	9.409 [239]	[105]	[21]	[20]	[14]	[180]	[130]	[129]	[18]	[143]	[195]	[215]	[220]

		L	M	N _{h8}	O	P	Q
NF160	inch [mm]	6.299 [160]	5.118 [130]	4.330 [110]	0.433 [11]	0.137 [3.5]	0.433 [11]
NF200	inch [mm]	7.874 [200]	6.496 [165]	5.118 [130]	0.511 [13]	0.137 [3.5]	0.433 [11]
NF250	inch [mm]	9.842 [250]	8.464 [215]	7.086 [180]	0.551 [14]	0.157 [4]	0.433 [11]

NEMA		A		DF	
		P	NF		
352	143/145TC	inch [mm]	9.213 [234]	10.197 [259]	6.500 [165.1]
	182/184TC	inch [mm]	9.449 [240]	10.433 [265]	9.000 [228.6]
353	56C	inch [mm]	9.016 [229]	10.000 [254]	6.500 [165.1]
	143/145TC	inch [mm]	9.016 [229]	10.000 [254]	6.500 [165.1]

1 Input shaft / Eje de entrada

		D ₁	E ₁	F	G	H	I	U	V
352	inch [mm]	1.000 [25.400]	1.969 [50.012]	5/16-18	0.709 [18.009]	1.109 [28.168]	0.250 [6.350]	1.500 [38.100]	0.469 [11.913]
353	inch [mm]	0.750 [19.050]	1.575 [40.005]	5/16-18	0.709 [18.009]	0.832 [21.133]	0.187 [4.750]	1.000 [25.400]	0.575 [14.605]

2 Output shaft / Eje de salida

		D ₂	E ₂	F	G	H	I	U	V
352	inch [mm]	1.375 [34.925]	3.150 [80.010]	3/8-16	0.906 [23.012]	1.513 [38.430]	0.312 [7.925]	2.500 [63.500]	0.650 [16.510]
353	inch [mm]	1.375 [34.925]	3.150 [80.010]	3/8-16	0.906 [23.012]	1.513 [38.430]	0.312 [7.925]	2.500 [63.500]	0.650 [16.510]

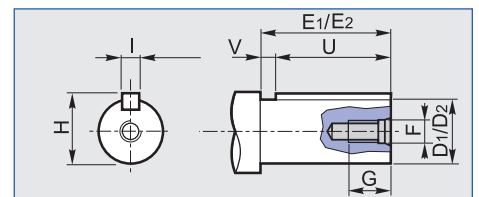
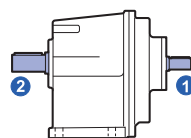



452 - 453

P

RCV ...

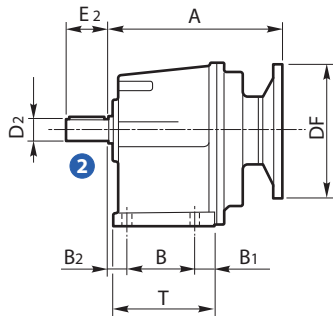

CV ...

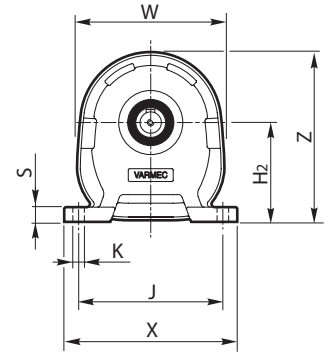
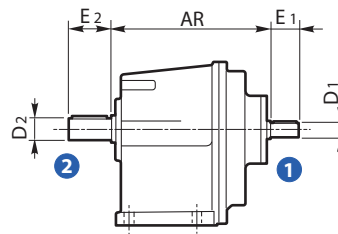

F

RCV ...

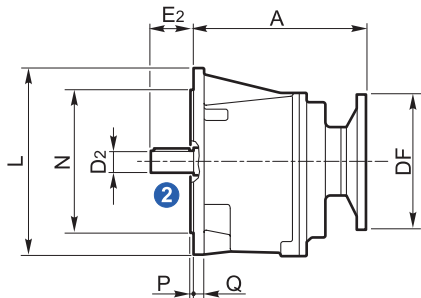

CV ...

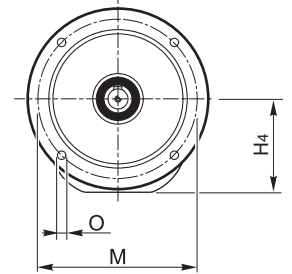
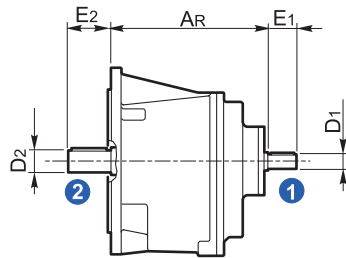

N.B.
F = Flange mount
F = Brida integral

RCV		AR	B	B ₁	B ₂	K	J	H ₂	H ₄	S	T	W	X	Z
452	inch	9.646 [245]	4.330	1.259	0.984	0.708	8.858	6.102	5.984	0.866	6.456	9.055	10.629	10.433
453	[mm]	10.039 [255]	[110]	[32]	[25]	[18]	[225]	[155]	[152]	[22]	[164]	[230]	[270]	[265]

		L	M	N h8	O	P	Q
F300	inch [mm]	11.811 [300]	10.433 [265]	9.055 [230]	0.511 [14]	0.197 [5]	0.709 [18]

		NEMA		A	DF
452	143/145TC	inch [mm]	10.472 [266]	6.500 [165.1]	
	182/184TC	inch [mm]	10.709 [272]	9.000 [228.6]	
	213/215TC	inch [mm]	10.709 [272]	9.000 [228.6]	
453	143/145TC	inch [mm]	10.630 [270]	6.500 [165.1]	
	182/184TC	inch [mm]	10.866 [276]	9.000 [228.6]	

1		Input shaft / Eje de entrada							
		D ₁	E ₁	F	G	H	I	U	V
452	inch [mm]	1.125 [28.575]	2.362 [59.994]	5/16-18	0.709 [18.009]	1.236 [31.394]	0.250 [6.350]	1.750 [44.450]	0.612 [15.545]
453	inch [mm]	1.000 [25.400]	1.969 [50.012]	5/16-18	0.709 [18.009]	1.109 [28.168]	0.250 [6.350]	1.500 [38.100]	0.469 [11.913]

2		Output shaft / Eje de salida							
		D ₂	E ₂	F	G	H	I	U	V
452	inch	1.750	3.543	1/2-13	1.299	1.917	0.375	3.000	0.543
453	[mm]	[44.450]	[89.992]		[32.994]	[48.691]	[9.525]	[76.200]	[13.792]

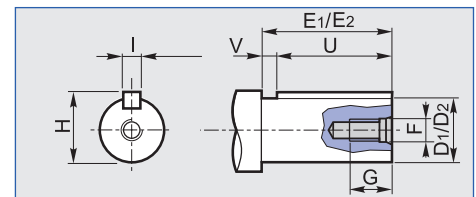
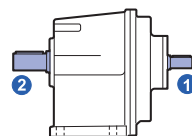



4.9 Dimensions

4.9 Dimensiones

552 - 553

P

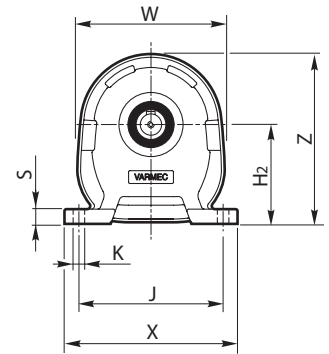
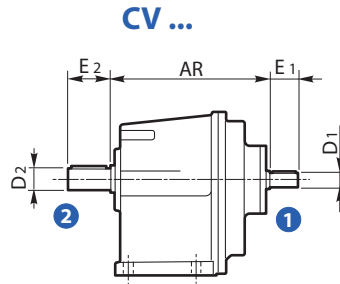
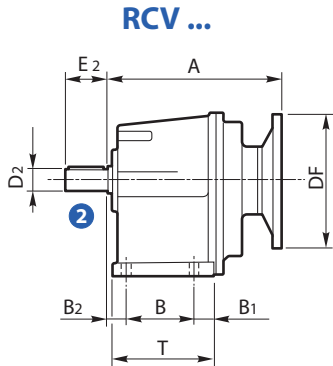

F

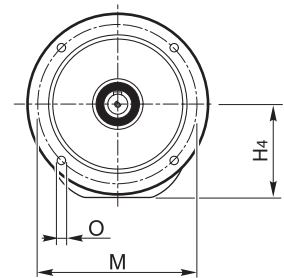
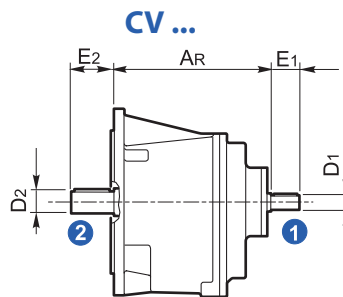
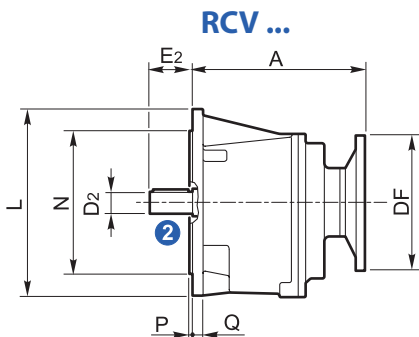

N.B.
F = Flange mount
F = Brida integral

RCV		AR	B	B ₁	B ₂	K	J	H ₂	H ₄	S	T	W	X	Z
552	inch	12.402 [315]	5.708	1.200	0.984	0.708	9.842	7.677	7.559	0.984	7.795	10.826	11.811	12.795
553	[mm]	12.008 [305]	[145]	[30.5]	[25]	[18]	[250]	[195]	[192]	[25]	[198]	[275]	[300]	[325]

		L	M	N _{h8}	O	P	Q	
F300		inch [mm]	11.811 [300]	10.433 [265]	9.055 [230]	0.511 [14]	0.197 [5]	0.709 [18]

		NEMA		A	DF
552	182/184TC	inch [mm]	12.008 [305]	9.000 [228.6]	
	213/215TC	inch [mm]	12.008 [305]	9.000 [228.6]	
	254/256TC	inch [mm]	13.031 [331]	9.000 [228.6]	
	284/286TC	inch [mm]	13.661 [347]	11.252 [285.8]	
553	143/145TC	inch [mm]	12.795 [325]	6.500 [165.1]	
	182/184TC	inch [mm]	13.031 [331]	9.000 [228.6]	
	213/215TC	inch [mm]	13.031 [331]	9.000 [228.6]	

1		Input shaft / Eje de entrada							
		D ₁	E ₁	F	G	H	I	U	V
552	inch [mm]	1.500 [38.100]	3.150 [80.010]	3/8-16	0.906 [23.012]	1.664 [42.265]	0.375 [9.525]	2.750 [69.850]	0.400 [10.160]
553	inch [mm]	1.125 [28.575]	2.362 [59.994]	5/16-18	0.709 [18.009]	1.236 [31.394]	0.250 [6.350]	1.750 [44.450]	0.612 [15.545]

2		Output shaft / Eje de salida							
		D ₂	E ₂	F	G	H	I	U	V
552	inch	2.187	4.330	5/8-11	1.772	2.409	0.500	3.250	1.081
553	[mm]	[55.549]	[109.982]		[45.008]	[61.188]	[12.700]	[82.550]	[27.203]

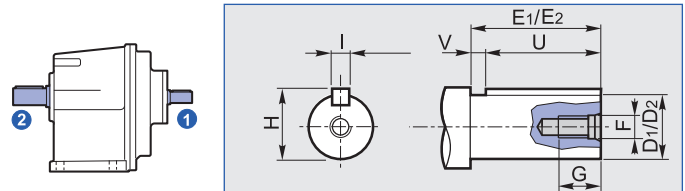



582 - 583

P

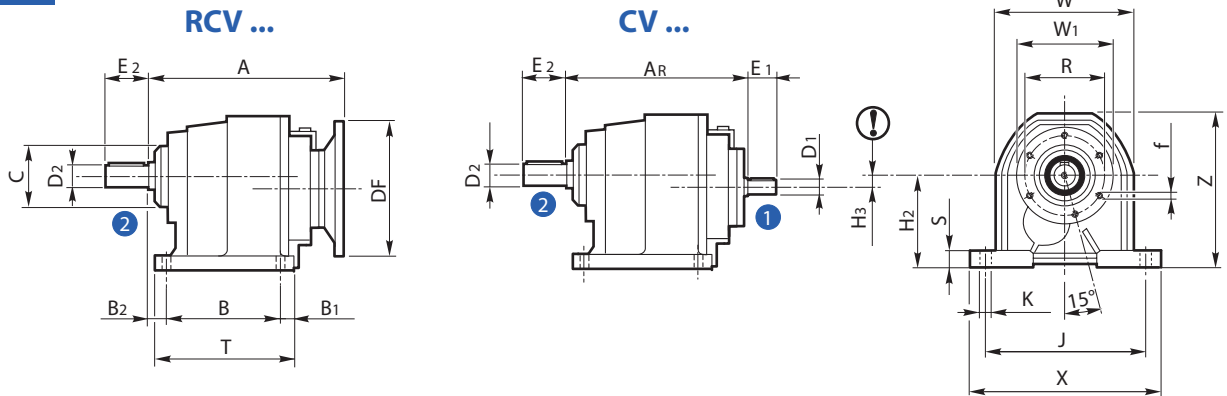

NF

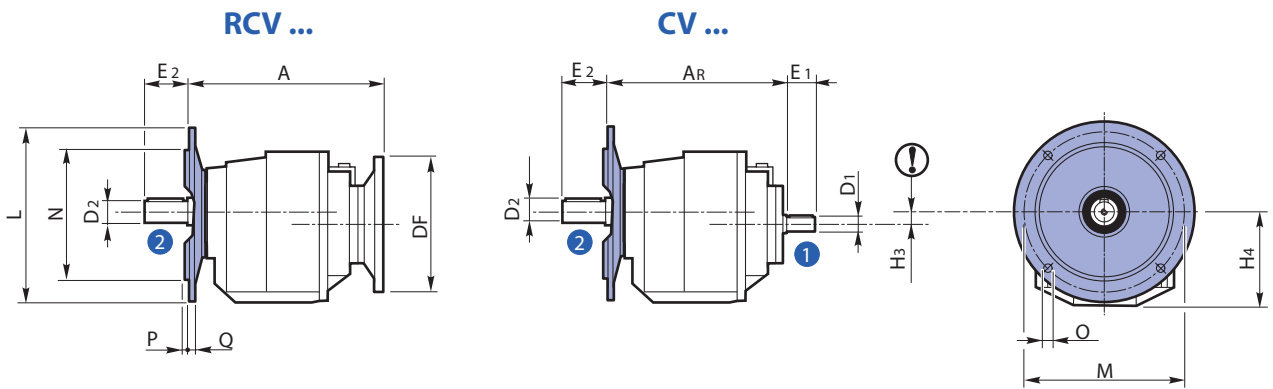

RCV		AR	B	B ₁	B ₂	C h7	f	K	J	H ₂	H ₃	H ₄	R	S	T	W	W ₁	X	Z
582	inch	14.488 [368]	6.496	2.126	0.984	5.906		0.866	11.811	8.268	0.335	8.268	7.087	1.181	9.449	8.661	7.087	13.780	13.583
583	[mm]	13.976 [355]	[165]	[54]	[25]	[150]	M14	[22]	[300]	[210]	[8.5]	[210]	[180]	[30]	[240]	[220]	[180]	[350]	[345]

		L	M	N h8	O	P	Q
NF300	inch	11.811	10.433	9.055	0.551	0.197	0.669
	[mm]	[300]	[265]	[230]	[14]	[5]	[17]
NF350	inch	13.780	11.811	9.843	0.709	0.197	0.669
	[mm]	[350]	[300]	[250]	[18]	[5]	[17]

		NEMA	A	DF
582	182/184TC	inch [mm]	14.094 [358]	9.000 [228.6]
	213/215TC	inch [mm]	14.094 [358]	9.000 [228.6]
	254/256TC	inch [mm]	15.118 [384]	9.000 [228.6]
	284/286TC	inch [mm]	15.748 [400]	11.251 [285.8]
583	143/145TC	inch [mm]	14.803 [376]	6.500 [165.1]
	182/184TC	inch [mm]	15.039 [382]	9.000 [228.6]
	213/215TC	inch [mm]	15.039 [382]	9.000 [228.6]

	1 Input shaft / Eje de entrada								
		D ₁	E ₁	F	G	H	I	U	V
582	inch [mm]	1.500 [38.100]	3.150 [80.010]	3/8-16	0.906 [23.012]	1.664 [42.265]	0.375 [9.525]	2.750 [69.850]	0.400 [10.160]
583	inch [mm]	1.125 [28.575]	2.362 [59.994]	5/16-18	0.709 [18.009]	1.236 [31.394]	0.250 [6.350]	1.750 [44.450]	0.612 [15.545]

	2 Output shaft / Eje de salida								
		D ₂	E ₂	F	G	H	I	U	V
582	inch	2.375	4.724	3/4-10	1.966	2.646	0.625	3.500	1.224
583	[mm]	[60.325]	[119.989]		[49.936]	[67.208]	[15.875]	[88.900]	[31.089]

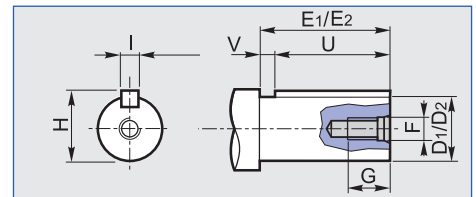
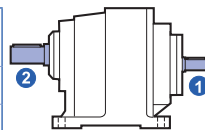



4.9 Dimensions

4.9 Dimensiones

602 - 603

P

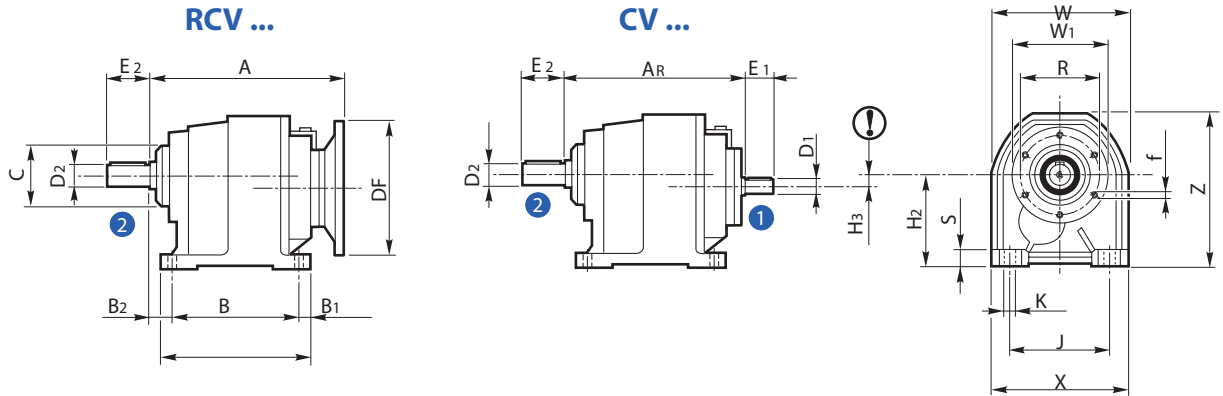

NF

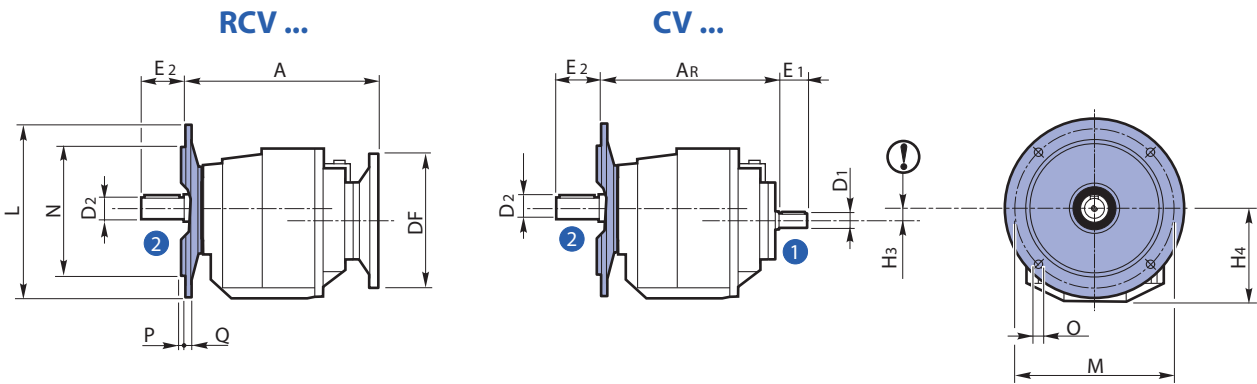

RCV	AR	B	B ₁	B ₂	C _{h7}	f	K	J	H ₂	H ₃	H ₄	R	S	T	W	W ₁	X	Z	
602	inch	15.944 [405]	12.205	1.083	1.575	5.906		0.866	9.843	8.858	1.118	8.740	7.087	1.378	14.370	8.661	7.087	13.386	14.764
603	[mm]	16.732 [425]	[310]	[27.5]	[40]	[150]	M14	[22]	[250]	[225]	[28.4]	[222]	[180]	[35]	[365]	[220]	[180]	[340]	[375]

	L	M	N _{h8}	O	P	Q	
NF300	inch [mm]	11.811 [300]	10.433 [265]	9.055 [230]	0.551 [14]	0.197 [5]	0.669 [17]
NF350	inch [mm]	13.780 [350]	11.811 [300]	9.843 [250]	0.709 [18]	0.197 [5]	0.669 [17]

NEMA		A	DF	
602	182/184TC	inch [mm]	16.574 [421]	9.000 [228.6]
	213/215TC	inch [mm]	16.574 [421]	9.000 [228.6]
	254/256TC	inch [mm]	16.574 [421]	9.000 [228.6]
	284/286TC	inch [mm]	17.205 [437]	11.252 [285.8]
603	182/184TC	inch [mm]	12.795 [325]	9.000 [228.6]
	213/215TC	inch [mm]	13.031 [331]	9.000 [228.6]
	254/256TC	inch [mm]	13.031 [331]	9.000 [228.6]

1 Input shaft / Eje de entrada

	D ₁	E ₁	F	G	H	I	U	V	
602	inch [mm]	1.500 [38.100]	3.150 [80.010]	3/8-16	0.906 [23.012]	1.664 [42.265]	0.375 [9.525]	2.750 [69.850]	0.400 [10.160]
603	inch [mm]	1.500 [38.100]	3.150 [80.010]	3/8-16	0.906 [23.012]	1.664 [42.265]	0.375 [9.525]	2.750 [69.850]	0.400 [10.160]

2 Output shaft / Eje de salida

	D ₂	E ₂	F	G	H	I	U	V
602	inch	2.375	3/4-10	1.966	2.646	0.625	3.500	1.224
603	[mm]	[60.325]	[119.989]	[49.936]	[67.208]	[15.875]	[88.900]	[31.089]

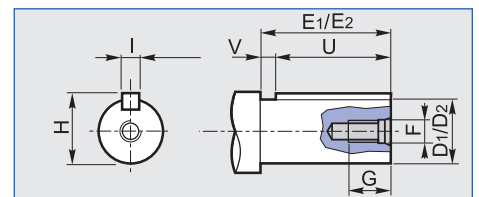
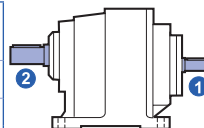



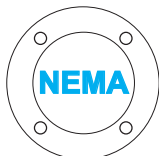

E	Shaft-mountes reducers RFV	<i>Reductores pendulares</i> RFV	E1
----------	--------------------------------------	--	-----------

INDEX	<i>INDICE</i>	
5.1 Characteristics	<i>Características</i>	E2
5.2 Construction shapes	<i>Formas de fabricación</i>	E2
5.3 Designation	<i>Nomenclatura</i>	E3
5.4 Lubrication	<i>Lubricación</i>	E4
5.5 Quantity of lubricant	<i>Cantidad de lubricante</i>	E4
5.6 Assembly positions	<i>Posiciones de montaje</i>	E5
5.7 Radial load	<i>Cargas radiales</i>	E10
5.8 Technical data	<i>Datos técnicos</i>	E12
5.9 Dimensions	<i>Dimensiones</i>	E17
5.10 Accessorios	<i>Accesorios</i>	E23

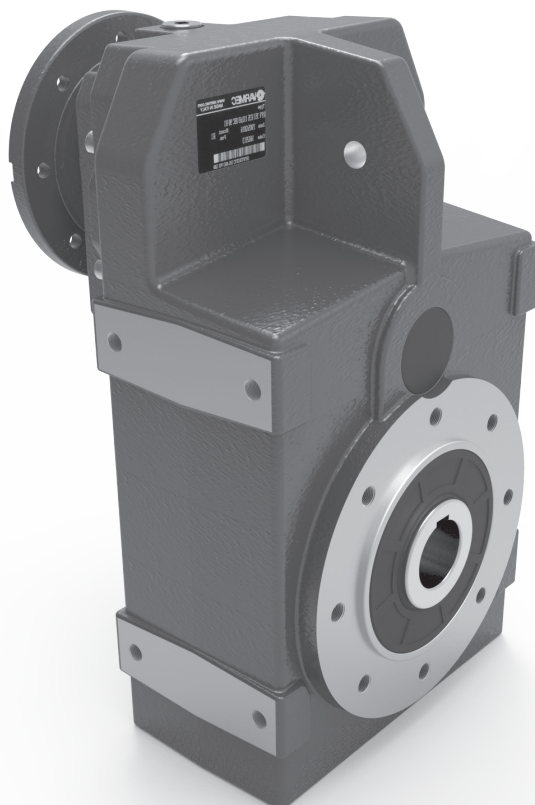



Shaft-mounted reducers RFV

5.1 Characteristics

VARMEC reducers and gearmotors have been designed entirely with the aid of technical computer programs. Every single component has been checked and designed taking into account the maximum load applicable to the reducer according to the AGMA 2001-B88 regulation, in compliance with the modularity characteristics.

Casings and flanges are made of unpainted aluminium in sizes 252-253, 302-303, while the casings and flanges made of high resistance cast-iron are painted in the other sizes. The rounded shape of the casings gives the reducers excellent rigidity and solidity and allows them to be used in all possible assembly positions.

The various components are processed on modern CNC machinery, ensuring maximum constructive precision.

All gears are made of alloyed, hardened and tempered steel with subsequent grinding on the sides of the teeth to improve performance and silent operation even under load. Approximate maximum sound level values 75dB.

The input shaft is made of alloyed, cemented and hardened steel; the output shaft is made of reclaimed steel.

The reducers are painted with a polyester resin-based thermosetting powder, modified with epoxy resin, in RAL5010 Textured Blue.

More information on the paint specifications can be requested from our Technical Department.

5.2 Construction shapes

RFV ...

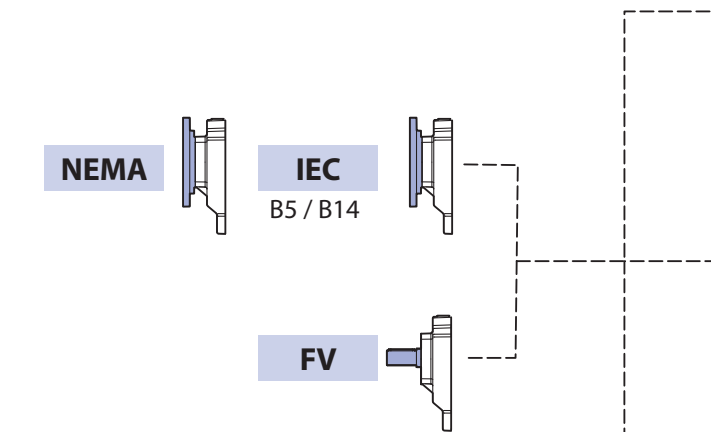

H Keyed hollow output shaft
Eje de salida hueco con llave

S Hollow output shaft and shrink disc
Eje de salida hueco y disco de contracción

R Solid output shaft
Eje de salida sólido

Reductores pendulares RFV

5.1 Características

Los reductores y los motorreductores VARMEC se han diseñado por dentro con programas técnicos basados en programas de ordenador.

Cada componente se ha comprobado y diseñado considerando la carga máxima aplicable al reductor, según la normativa AGMA 2001-B88 respetando las características de modularidad.

Cajas y bridas de aluminio sin pintar de tamaño 252-253, 302-303, cajas y bridas de fundición de alta resistencia pintadas en otros tamaños. La forma monolítica de las cajas aporta una excelente rigidez a los reductores y un alto nivel de compacidad y permite que se usen en todas las posiciones posibles de montaje.

Las elaboraciones de los diferentes componentes se producen en centros de mecanizado modernos, con control numérico, que permiten la máxima precisión de fabricación.

Todos los engranajes se han fabricado con aleación de acero, cementados y templados con la sucesiva elaboración de rectificado en los lados de los dientes, para mejorar el rendimiento y para que el funcionamiento incluso bajo carga, sea lo más silencioso posible. Valores indicativos máximos de nivel sonoro 75dB.

El eje de entrada se ha fabricado con acero aleado, cementado y templado, el de salida en acero bonificado.

Los reductores se pintan con polvo de endurecimiento termoestable a base de resinas de poliéster modificadas con resina epoxi de color Azul genciana RAL5010.

Se puede solicitar más información sobre las especificaciones de la pintura a nuestro Departamento Técnico.

5.2 Formas de fabricación

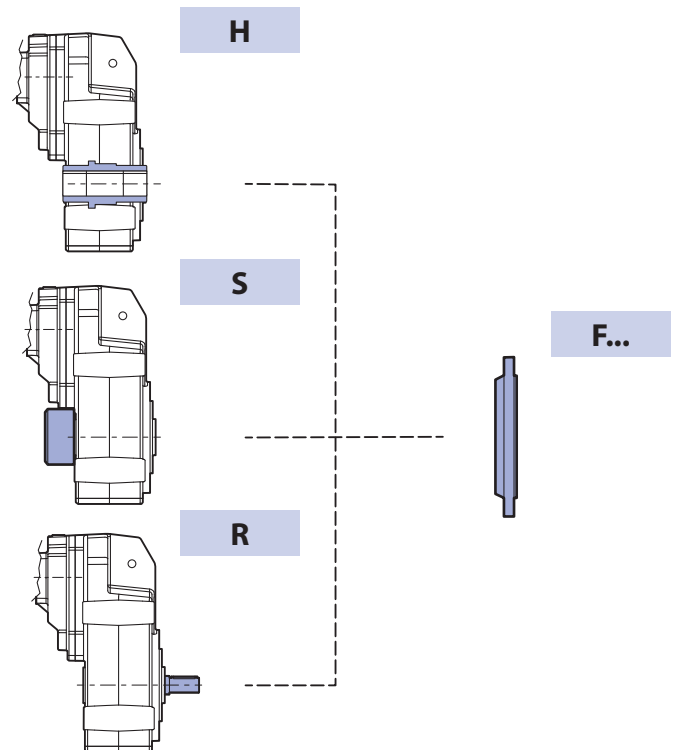



5.3 Designation

5.3 Nomenclatura

GEAR REDUCER / REDUCTOR

RFV 35 3 H35 110.69 F200 NEMA H1 ...

RFV

TYPE OF GEAR REDUCER
TIPO DE REDUCTOR

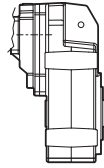

35

SIZE
TAMANO DEL REDUCTOR

25, 30, 35, 40, 50

3

N. OF STAGES OF REDUCTION
Nº ESTADOS DE REDUCCION

2, 3

H35

STRUCTURAL SHAPE
FORMA CONSTRUCTIVA

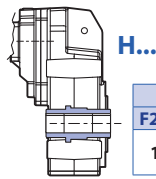

H...

H ..				
F25..	F30..	F35..	F40..	F50..
1"	1 1/4"	1 3/8"	1 1/2"	2"

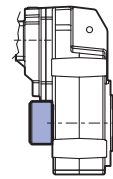

S

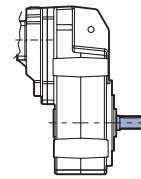

R



110.69

REDUCTION RATIO
RELACION DE REDUCCION

F200

OUTPUT FLANGE
BRIDA DE SALIDA

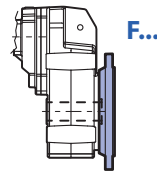
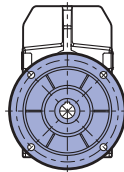

F...

NEMA

TYPE OF INPUT
TIPO DE ENTRADA



IEC
B5/B14

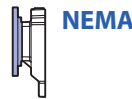

NEMA



FV

H1

ASSEMBLY POSITION
POSICION DE MONTAJE



E5

...

OPTIONS
OPCIONES



E20



5.4 Lubrication

All gearboxes manufactured by VARMEC are designed with synthetic oil lubrication.

Gearboxes from size RFV 25.. to RFV 40.. are supplied with lubricant from the factory. These gearboxes do not require periodic lubricant replacement throughout their service life.

The gearboxes of the RFV 502-503 series are normally supplied without lubricant, if not specified in the order, and it is the customer's responsibility to introduce the correct amount of lubricating oil before commissioning.

In this regard, the gearboxes are fitted with filler caps, drain and oil level plugs; for gearboxes supplied with lubricant it is recommended, after installation, to replace the closed plug used for transport, with the breather plug provided.

In order to fit the plugs with the correct orientation, it is recommended to always specify the desired assembly position for proper lubrication. In the assembly positions that feature gearboxes with a vertical axis (H5, H6), where the oil splashing during operation would not be enough to ensure proper lubrication of the upper bearings, type 2RS self-lubricating bearings are fitted.

To fill the gearbox properly, refer to the centreline of the level plug.

With respect to this condition, the quantity of lubricant shown in table 1 may feature deviations.

The operation of the gearboxes is permitted for ambient temperatures ranging between -20°C and +40°C.

5.5 Quantity of lubricant

5.4 Lubrication

Todos los reductores de producción de la empresa VARMEC llevan lubricación con aceite sintético.

Los reductores del tamaño RFV 25.. al RFV 40.. se suministran lubricados de fábrica. Estos reductores no necesitan la sustitución periódica del lubricante durante toda su vida útil.

Los reductores de la serie RFV 502-503 normalmente se suministran sin lubricante, si no se especifica en el pedido, el cliente debe introducir la cantidad adecuada de aceite antes de la puesta en servicio.

Para ello los reductores están equipados con tapones de carga, descarga y de nivel para los reductores que se suministran con lubricante, se aconseja que después de la instalación se cambie el tapón cerrado, usado para el transporte, con el tapón de purga que se suministra.

Para orientar correctamente los tapones, para lubricar adecuadamente, recomendamos indicar siempre la posición en la que desea montarlos. En las posiciones de montaje que prevén los reductores con un eje vertical (H5, H6), después de que el aceite sea sacudido mientras funciona, esto no es suficiente para asegurar la lubricación correcta de los cojinetes superiores, se montan cojinetes con lubricación automática tipo 2RS.

Para el llenado correcto del reductor se deberá tomar como referencia absoluta el nivel a mitad del tapón.

Respecto a esta condición, la cantidad de lubricante indicada en la tabla 1 puede sufrir variaciones.

El funcionamiento de los reductores se admite para temperaturas ambiente entre los -20°C y los +40°C.

5.5 Cantidad de lubricante

Tab.1

RFV	Assembly position / Posición de montaje											
	H1		H2		H3		H4		H5		H6	
252	0.317	[1.2]	0.290	[1.1]	0.185	[0.7]	0.185	[0.7]	0.317	[1.2]	0.238	[0.9]
253	0.330	[1.25]	0.290	[1.1]	0.185	[0.7]	0.185	[0.7]	0.343	[1.3]	0.238	[0.9]
302	0.422	[1.6]	0.370	[1.4]	0.211	[0.8]	0.211	[0.8]	0.396	[1.5]	0.343	[1.3]
303	0.449	[1.7]	0.370	[1.4]	0.211	[0.8]	0.211	[0.8]	0.422	[1.6]	0.343	[1.3]
352	0.713	[2.7]	0.686	[2.6]	0.422	[1.6]	0.422	[1.6]	0.766	[2.9]	0.686	[2.6]
353	0.792	[3]	0.686	[2.6]	0.422	[1.6]	0.422	[1.6]	0.818	[3.1]	0.686	[2.6]
402	1.267	[4.8]	0.950	[3.6]	0.739	[2.8]	0.739	[2.8]	1.241	[4.7]	1.162	[4.4]
403	1.346	[5.1]	0.950	[3.6]	0.739	[2.8]	0.739	[2.8]	1.241	[4.7]	1.162	[4.4]
502	1.769	[6.7]	1.584	[6]	1.162	[4.4]	1.162	[4.4]	2.033	[7.7]	1.690	[6.4]
503	1.980	[7.5]	1.584	[6]	1.162	[4.4]	1.162	[4.4]	2.033	[7.7]	1.690	[6.4]

Permanent lubrication / Lubricación permanente

Amount of oil expressed in gal [lt] / Cantidad de aceite expresada en gal [lt]



5.6 Assembly positions

5.6 Posiciones de montaje

The tables below should be used as a reference for the interpretation of the assembly positions, the position of the plugs and the quantities of lubricant.

Las tablas siguientes sirven de referencia para interpretar las posiciones de montaje, la colocación de los tapones y la cantidad de lubricante.

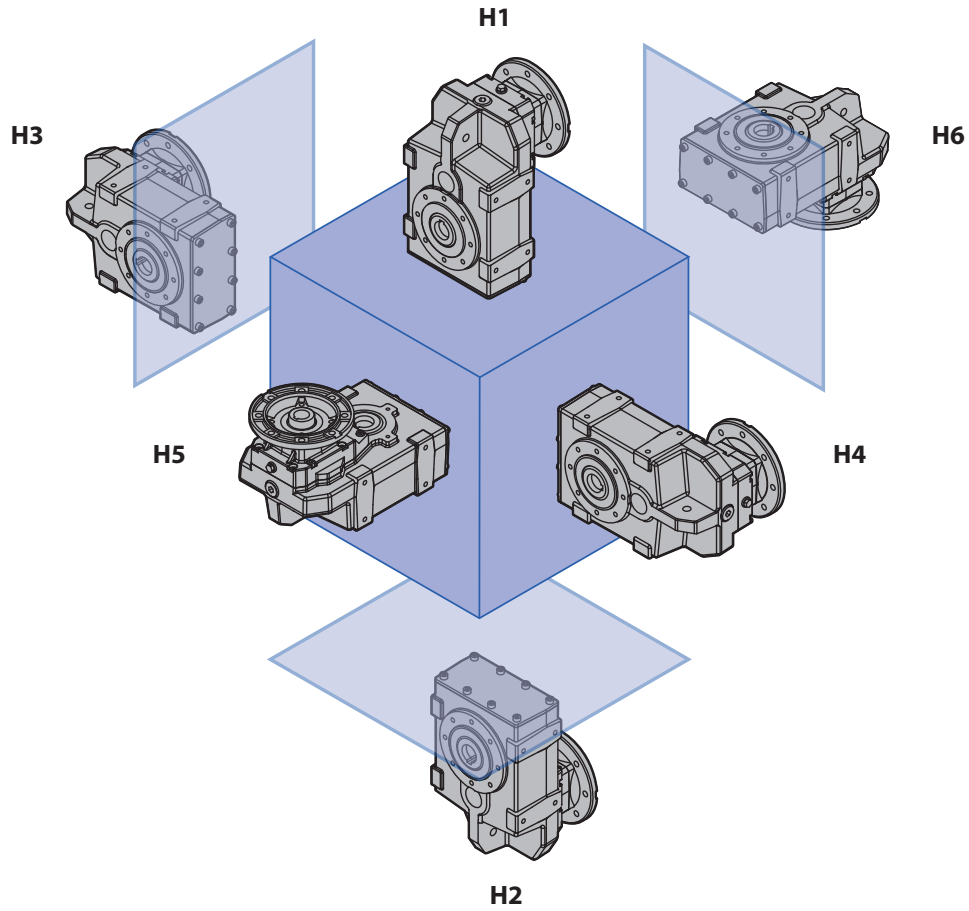



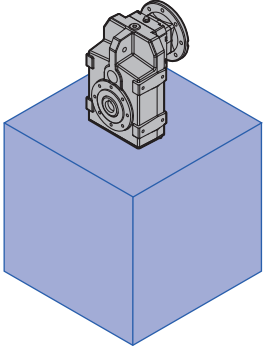
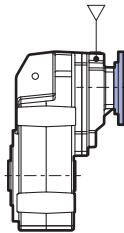
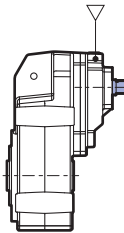
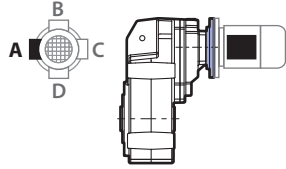
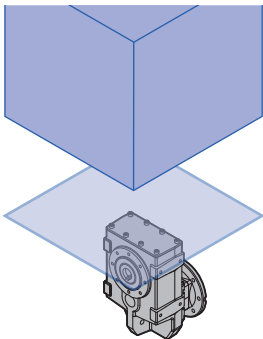
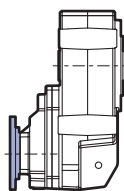
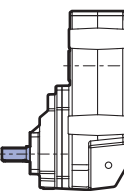
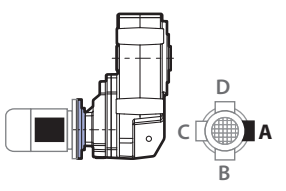
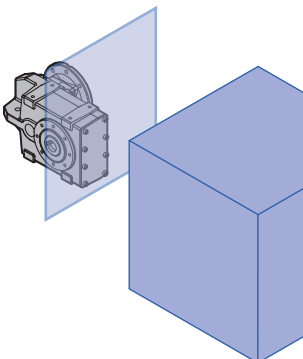
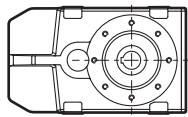
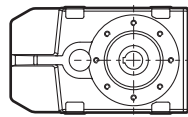
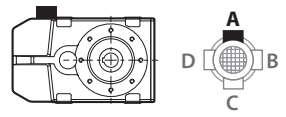

RFV 25... - RFV 30... - RFV 35...

H1	...NEMA	...FV	
			 <p>A = Standard</p>
H2	...NEMA	...FV	
			 <p>A = Standard</p>
H3	...NEMA	...FV	
			 <p>A = Standard</p>

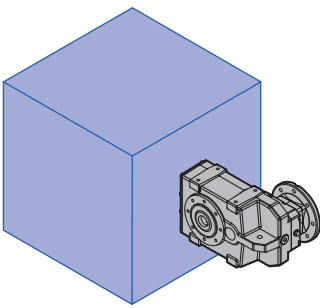
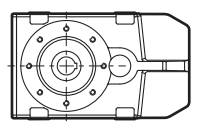
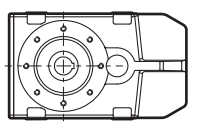
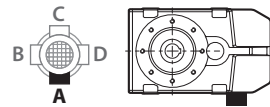
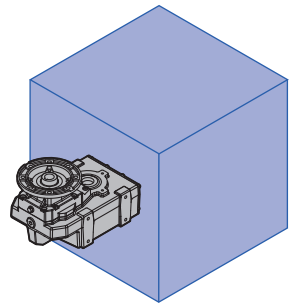
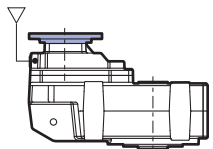
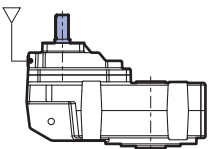
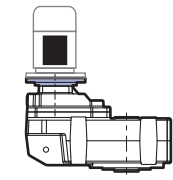
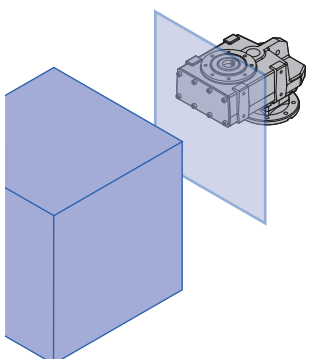
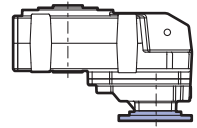
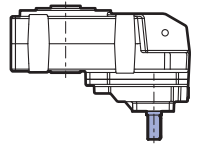

RFV 25... - RFV 30... - RFV 35...

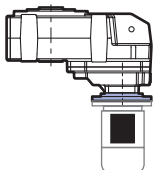
H4	...NEMA	...FV	
			 <p>A = Standard</p>
H5	...NEMA	...FV	
			 <p>A = Standard</p>
H6	...NEMA	...FV	
			  <p>A = Standard</p>



RFV 40... - RFV 50...

H1	...NEMA	...FV	
			<p>A = Standard</p>
			<p>A = Standard</p>
			<p>A = Standard</p>

(2): 2 stages of reductions / 2 estados de reduccion
 (3): 3 stages of reductions / 3 estados de reduccion

- ▽ Breather plug / Tapón respiradero
- Filler cap / Carga aceite
- Oil level plug / Nivel aceite
- Drain plug / Descarga de aceite

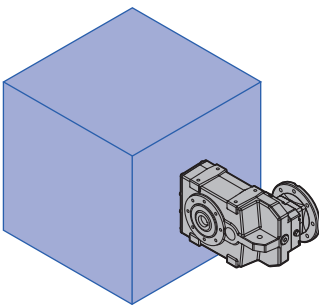
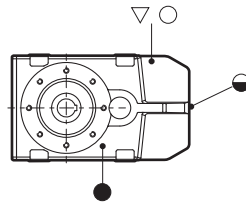
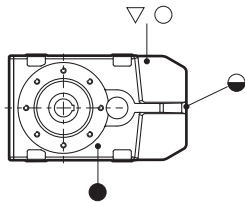
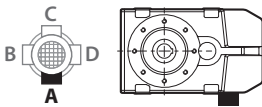
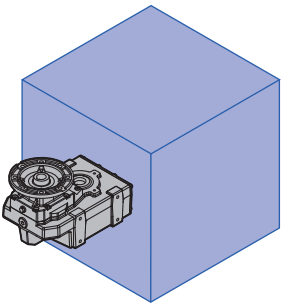
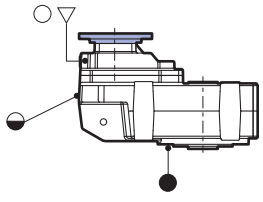
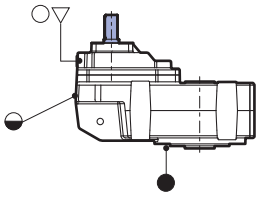
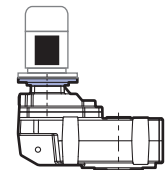
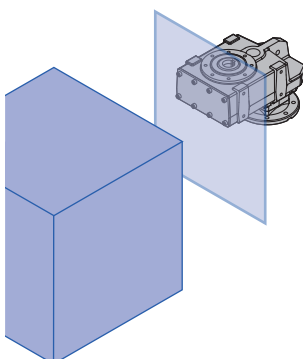
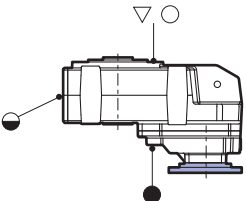
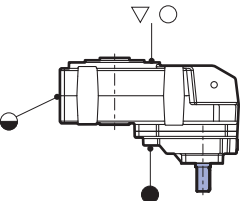
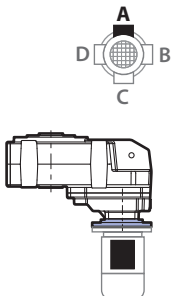

RFV 40... - RFV 50...

H4	...NEMA	...FV	
			 <p style="text-align: center;">A = Standard</p>
H5	...NEMA	...FV	
			 <p style="text-align: center;">A = Standard</p>
H6	...NEMA	...FV	
			 <p style="text-align: center;">A = Standard</p>

- ▽ Breather plug / Tapón respiradero
- Filler cap / Carga aceite
- Oil level plug / Nivel aceite
- Drain plug / Descarga de aceite



5.7 Radial load

Any transmission device coupled to the input and output shaft generates radial loads.

The load values reported in the table, depending on input and output speed, are to be considered as acting at the half-way point of the projection; if the load is applied at 1/3 of the projection, increase the values in the table by 25%; if the load is applied at 2/3, reduce the values by 25%.

With regard to double projecting shafts, each end can sustain a radial load which equals 3/5 of the values listed in the table, on condition that they act in the same direction and have the same intensity.

5.7 Cargas radiales

Cada clase de órgano de transmisión que es conectado al eje de entrada y salida determina cargas radiales.

Los valores señalados en la tabla en función a las varias velocidades de entrada y salida se suponen aplicándolas en la mitad del eje como fuerzas agentes a esta; para una ubicación de 1/3 de la longitud se aumentará hasta un 25% los valores de la tabla, mientras para una posición de 2/3 de la longitud se disminuirá los mismos valores a un 25%.

En los ejes con salida doble, cada extremidad puede soportar una carga radial igual a 3/5 del valor de la tabla, siempre y cuando las cargas aplicables sean de igual intensidad y reaccionen en el mismo sentido.

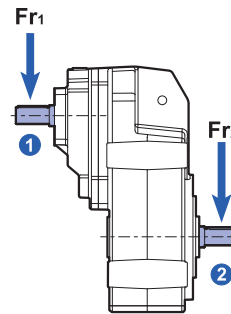
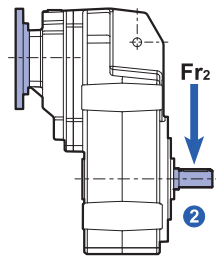
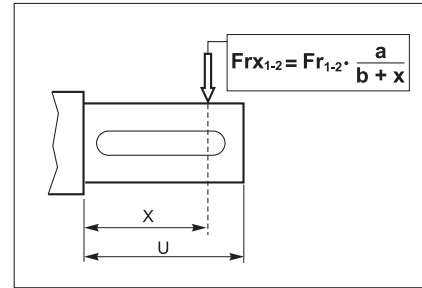
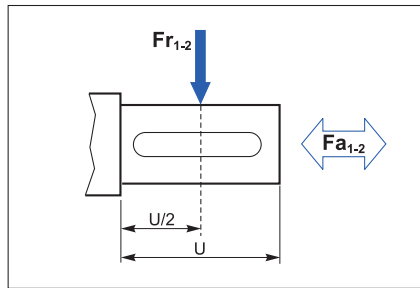

		Fr_1									
n_1 [min ⁻¹]		FRV...FV									
		252	253	302	303	352	353	402	403	502	503
2800	lbf	166	111	166	111	222	166	388	166	749	222
	[N]	[300]	[200]	[300]	[200]	[400]	[300]	[700]	[300]	[1350]	[400]
1750	lbf	346	208	346	208	416	346	729	346	1388	416
	[N]	[625]	[375]	[625]	[375]	[750]	[625]	[1315]	[625]	[2500]	[751]
1400	lbf	277	166	277	166	333	277	583	277	1110	333
	[N]	[500]	[300]	[500]	[300]	[600]	[500]	[1050]	[500]	[2000]	[600]
900	lbf	322	194	322	194	388	322	677	322	1287	388
	[N]	[580]	[350]	[580]	[350]	[700]	[580]	[1220]	[580]	[2320]	[700]
700	lbf	350	211	350	211	422	350	732	350	1398	422
	[N]	[630]	[380]	[630]	[380]	[760]	[630]	[1320]	[630]	[2520]	[760]
500	lbf	388	239	388	239	472	388	821	388	1570	472
	[N]	[700]	[430]	[700]	[430]	[850]	[700]	[1480]	[700]	[2830]	[850]
300	lbf	460	277	460	277	555	460	971	460	1859	555
	[N]	[830]	[500]	[830]	[500]	[1000]	[830]	[1750]	[830]	[3350]	[1000]
a	inch	2.984	2.413	2.984	2.413	3.898	2.984	4.709	2.984	6.339	3.898
	[mm]	[75.8]	[61.3]	[75.8]	[61.3]	[99]	[75.8]	[119.6]	[75.8]	[161]	[99]
b	inch	2.197	1.626	2.197	1.626	2.913	2.197	3.528	2.197	4.764	2.913
	[mm]	[55.8]	[41.3]	[55.8]	[41.3]	[74]	[55.8]	[89.6]	[55.8]	[121]	[74]



5.7 Radial load

5.7 Cargas radiales

Fr ₂						
n ₂ [min ⁻¹]		FRV...FV				
		252 - 253	302 - 303	352 - 353	402 - 403	502 - 503
400	lbf	777	832	1553	1942	2219
	[N]	[1400]	[1500]	[2800]	[3500]	[4000]
300	lbf	832	888	1664	2053	2497
	[N]	[1500]	[1600]	[3000]	[3700]	[4500]
250	lbf	888	943	1831	2219	2552
	[N]	[1600]	[1700]	[3300]	[4000]	[4600]
200	lbf	943	999	1942	2386	2774
	[N]	[1700]	[1800]	[3500]	[4300]	[5000]
150	lbf	971	1054	2108	2552	3051
	[N]	[1750]	[1900]	[3800]	[4600]	[5500]
100	lbf	1110	1221	2219	2774	3606
	[N]	[2000]	[2200]	[4000]	[5000]	[6500]
80	lbf	1165	1304	2441	2885	3884
	[N]	[2100]	[2350]	[4400]	[5200]	[7000]
60	lbf	1304	1442	2829	3329	4438
	[N]	[2350]	[2600]	[5100]	[6000]	[8000]
40	lbf	1526	1720	3440	3995	4993
	[N]	[2750]	[3100]	[6200]	[7200]	[9000]
20	lbf	1553	2219	3606	4716	6658
	[N]	[2800]	[4000]	[6500]	[8500]	[12000]
a	inch	4.921	5.709	6.654	7.539	9.094
	[mm]	[125]	[145]	[169]	[191.5]	[231]
b	inch	4.035	4.528	5.472	5.965	7.126
	[mm]	[102.5]	[115]	[139]	[151.5]	[181]



RFV	i	$n_1 = 1750 \text{ min}^{-1}$					FS'	
		n_2 min^{-1}	Ft·lb	T_2 Nm	Hp	P_1 kW		
252	7.81	224	75	101	2.7	2.00	1.0	143/145 TC 56 C
	9.33	188	80	109	2.4	1.80		
	10.66	164	84	114	2.2	1.65		
	12.36	142	88	119	2.0	1.49		
	14.11	124	97	131	1.9	1.43		
	16.85	104	103	140	1.7	1.28		
	19.25	91	108	146	1.6	1.17		
	20.17	87	111	151	1.6	1.16		
	23.04	76	115	156	1.4	1.04		
	25.63	68	123	167	1.4	1.01		
	30.61	57	130	176	1.2	0.89		
	34.96	50	135	183	1.1	0.81		
	40.56	43	140	190	1.0	0.72		
	45.12	39	148	200	0.9	0.68		
	49.39	35	148	200	0.8	0.62		
	53.89	32	148	200	0.8	0.57		
61.56	28	148	200	0.7	0.50			
71.42	25	148	200	0.6	0.43			
78.17	22	148	200	0.5	0.39			
253	79.92	22	148	200	0.66	0.49	1.0	56 C
	92.72	19	148	200	0.58	0.43		
	98.47	18	148	200	0.54	0.40		
	117.60	15	148	200	0.46	0.34		
	134.34	13	148	200	0.39	0.29		
	155.85	11	148	200	0.34	0.25		
	170.87	10	148	200	0.31	0.23		
	204.06	9	148	200	0.25	0.19		
	233.10	8	148	200	0.23	0.17		
	250.99	7	148	200	0.21	0.16		
	270.43	6	148	200	0.20	0.15		
	286.71	6	148	200	0.19	0.14		
	332.63	5	148	200	0.16	0.12		





5.8 Technical data

5.8 Datos técnicos

RFV	i	n ₁ = 1750 min ⁻¹						FS'	NEMA
		n ₂ min ⁻¹	Ft·lb	T ₂ Nm	Hp	P ₁ kW			
302	7.16	244	148	200	7.2	5.39	1.0	143/145 TC 56 C	
	8.09	216	170	230	7.3	5.48			
	9.26	189	188	255	7.1	5.31			
	10.76	163	202	274	6.6	4.91			
	12.73	137	214	290	5.9	4.39			
	14.39	122	221	300	5.4	4.02			
	16.47	106	232	315	4.9	3.69			
	17.60	99	236	320	4.7	3.51			
	19.14	91	239	324	4.4	3.27			
	20.14	87	244	330	4.2	3.16			
	23.40	75	251	340	3.8	2.80			
	26.46	66	258	350	3.4	2.55			
	30.28	58	258	350	3.0	2.23			
	34.71	50	258	350	2.6	1.95			
	40.34	43	258	350	2.2	1.67			
	44.56	39	258	350	2.0	1.52			
	50.38	35	258	350	1.8	1.34			
	57.66	30	258	350	1.6	1.17			
63.01	28	258	350	1.4	1.07				
67.01	26	258	350	1.4	1.01				
72.11	24	258	350	1.3	0.94				
83.81	21	258	350	1.1	0.81				
303	89.95	19	258	350	1.0	0.77	1.0	56 C	
	102.94	17	258	350	0.90	0.67			
	119.64	15	258	350	0.78	0.58			
	128.01	14	258	350	0.72	0.54			
	144.73	12	258	350	0.64	0.48			
	165.63	11	258	350	0.56	0.42			
	192.50	9	258	350	0.48	0.36			
	243.79	7	258	350	0.38	0.28			
	275.63	6	258	350	0.34	0.25			
	315.43	6	258	350	0.30	0.22			
	332.51	5	258	350	0.28	0.21			
	375.94	5	258	350	0.24	0.18			
	430.23	4	258	350	0.21	0.16			
	470.88	4	258	350	0.20	0.15			
	500.02	3	258	350	0.19	0.14			
	547.27	3	258	350	0.17	0.13			





RFV	i	$n_1 = 1750 \text{ min}^{-1}$					FS'	 NEMA
		n_2 min^{-1}	Ft·lb	T_2 Nm	Hp	P_1 kW		
352	5.55	315	215	292	13.6	10.15	1.0	182/184 TC 143/145 TC 56 C
	6.45	271	238	322	12.9	9.63		
	7.63	229	270	366	12.4	9.25		
	9.23	190	309	419	11.7	8.76		
	12.83	136	338	458	9.2	6.89		
	14.91	117	379	513	8.9	6.64		
	16.95	103	382	517	7.9	5.88		
	19.69	89	424	575	7.5	5.63		
	21.58	81	424	574	6.9	5.13		
	23.29	75	443	600	6.7	4.97		
	25.07	70	443	600	6.2	4.62		
	29.64	59	443	600	5.2	3.91		
	33.38	52	443	600	4.7	3.47		
	35.88	49	443	600	4.3	3.23		
	39.47	44	443	600	3.9	2.93		
	41.24	42	443	600	3.8	2.81		
	47.93	37	443	600	3.2	2.41	143/145 TC 56 C	
56.66	31	443	600	2.7	2.04			
68.58	26	443	600	2.3	1.69			
353	71.90	24	443	600	2.2	1.64	1.0	143/145 TC 56 C
	85.01	21	443	600	1.9	1.39		
	95.25	18	443	600	1.7	1.24		
	102.89	17	443	600	1.5	1.15		
	110.69	16	443	600	1.4	1.07		
	122.04	14	443	600	1.3	0.97		
	130.87	13	443	600	1.2	0.90		
	147.71	12	443	600	1.1	0.80		
	158.39	11	443	600	1.0	0.75		
	184.22	9	443	600	0.86	0.64		
	214.07	8	443	600	0.74	0.55		
	253.10	7	443	600	0.63	0.47		
	306.32	6	443	600	0.52	0.39		
	365.74	5	443	600	0.43	0.32		
	442.65	4	443	600	0.36	0.27		





5.8 Technical data

5.8 Datos técnicos

RFV	i	$n_1 = 1750 \text{ min}^{-1}$					FS'	NEMA
		n_2 min ⁻¹	Ft·lb	T_2 Nm	Hp	P_1 kW		
402	4.83	362	335	454	24.3	18.14	1.0	213/215 TC 182/184 TC 143/145 TC
	5.58	314	374	507	23.5	17.51		
	6.60	265	421	570	22.3	16.64		
	7.63	229	457	619	21.0	15.64		
	8.96	195	514	697	20.1	15.01		
	10.72	163	565	765	18.5	13.76		
	12.17	144	576	781	16.6	12.38		
	14.06	124	639	866	15.9	11.88		
	16.50	106	719	974	15.3	11.38		
	19.75	89	765	1037	13.6	10.13		
	22.60	77	768	1040	11.9	8.88		
	26.12	67	813	1101	10.9	8.13		
	30.64	57	886	1200	10.1	7.55		
	34.52	51	886	1200	9.0	6.71		
	40.50	43	886	1200	7.7	5.72		
	48.48	36	886	1200	6.4	4.78		
57.20	31	886	1200	5.4	4.05			
68.47	26	886	1200	4.5	3.38			
403	74.67	23	886	1200	4.3	3.17	1.0	143/145 TC 56 C
	86.31	20	886	1200	3.7	2.74		
	101.27	17	886	1200	3.1	2.34		
	108.91	16	886	1200	2.9	2.17		
	125.89	14	886	1200	2.5	1.88		
	138.65	13	886	1200	2.3	1.71		
	147.71	12	886	1200	2.1	1.60		
	160.26	11	886	1200	2.0	1.48		
	170.24	10	886	1200	1.9	1.39		
	188.04	9	886	1200	1.7	1.26		
	203.77	9	886	1200	1.6	1.16		
	213.38	8	886	1200	1.5	1.11		
	250.36	7	886	1200	1.3	0.94		
	265.04	7	886	1200	1.2	0.89		
	306.34	6	886	1200	1.0	0.77		
	359.44	5	886	1200	0.89	0.66		
430.24	4	886	1200	0.74	0.55			





RFV	i	$n_1 = 1750 \text{ min}^{-1}$					FS'	 NEMA	
		n_2 min ⁻¹	Ft·lb	T ₂ Nm	Hp	P ₁ kW			
502	6.03	290	738	1000	42.9	32.02	1.0	284/286 TC 254/256 TC 213/215 TC 182/184 TC 143/145 TC	
	7.06	248	801	1085	39.8	29.65			
	8.24	212	888	1203	37.7	28.14			
	9.66	181	1016	1377	36.9	27.52			
	11.54	152	1104	1496	33.6	25.02			
	12.73	137	1127	1527	31.0	23.14			
	13.55	129	992	1344	25.7	19.14		254/256 TC 213/215 TC 182/184 TC 143/145 TC	
	16.19	108	1178	1596	25.5	19.01			
	17.87	98	1292	1750	25.3	18.89			
	21.25	82	1525	2067	25.2	18.76			
	23.45	75	1627	2205	24.3	18.14			
	26.43	66	1632	2211	21.6	16.14			
	29.12	60	1547	2096	18.6	13.88		213/215 TC 182/184 TC 143/145 TC	
	32.14	54	1692	2293	18.5	13.76			
	37.14	47	1635	2215	15.4	11.51			
	39.46	44	1511	2047	13.4	10.01			
	43.56	40	1563	2118	12.6	9.38			
	52.16	34	1497	2029	10.1	7.51			
57.57	30	1515	2053	9.2	6.88	182/184 TC 143/145 TC			
73.67	24	1269	1720	6.0	4.50				
81.31	22	1362	1845	5.9	4.38				
503	79.95	22	1624	2200	7.3		5.42	1.0	182/184 TC 143/145 TC
	95.52	18	1624	2200	6.1		4.54		
	105.43	17	1624	2200	5.5		4.11		
	118.26	15	1624	2200	4.9	3.67			
	134.39	13	1624	2200	4.3	3.23			
	141.30	12	1624	2200	4.1	3.07			
	155.95	11	1624	2200	3.7	2.78			
	160.57	11	1624	2200	3.6	2.70			
	177.23	10	1624	2200	3.3	2.45			
	184.38	9	1624	2200	3.2	2.35			
	194.88	9	1624	2200	3.0	2.22			
	203.50	9	1624	2200	2.9	2.13			
	232.84	8	1624	2200	2.5	1.86			
	257.57	7	1624	2200	2.3	1.68			
	307.74	6	1624	2200	1.9	1.41			
	339.66	5	1624	2200	1.7	1.28			





5.9 Dimensions

5.9 Dimensiones

Input flange

Brida entrada

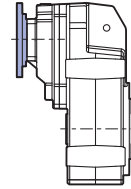
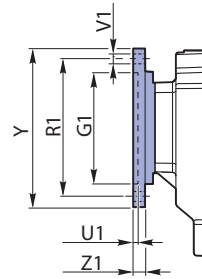

RFV	NEMA	G ₁	R ₁	U ₁	V ₁		Y	Z ₁		
					∅					
252	143/145 TC	4 1/2"	5 7/8"	0.216	0.413	4	6 1/2"	0.472		
	56C	[114.3]	[149.22]	[5.5]	[10.5]				[165.1]	[12]
253	56 C	4 1/2"	5 7/8"	0.216	0.413	4	6 1/2"	0.472		
		[114.3]	[149.22]	[5.5]	[10.5]		[165.1]	[12]		
302	143/145 TC	4 1/2"	5 7/8"	0.216	0.413	4	6 1/2"	0.472		
	56 C	[114.3]	[149.22]	[5.5]	[10.5]				[165.1]	[12]
303	56 C	4 1/2"	5 7/8"	0.216	0.413	4	6 1/2"	0.472		
		[114.3]	[149.22]	[5.5]	[10.5]		[165.1]	[12]		
352	182/184 TC	8 1/2"	7 1/4"	0.236	0.551	4	9	0.590		
		[215.9]	[184.15]	[6]	[14]				[228.6]	[15]
	143/145 TC	4 1/2"	5 7/8"	0.216	0.413	4	6 1/2"	0.472		
56 C	[114.3]	[149.22]	[5.5]	[11]	[165.1]				[12]	
353	143/145 TC	4 1/2"	5 7/8"	0.216	0.413	4	6 1/2"	0.472		
	56C	[114.3]	[149.22]	[5.5]	[10.5]				[165.1]	[12]
402	213/215 TC	8 1/2"	7 1/4"	0.236	0.551	4	9	0.590		
	182/184 TC	[215.9]	[184.15]	[6]	[14]				[228.6]	[15]
	143/145 TC	4 1/2"	5 7/8"	0.216	0.413	4	6 1/2"	0.472		
	[114.3]	[149.22]	[5.5]	[11]	[165.1]				[12]	
403	143/145 TC	4 1/2"	5 7/8"	0.216	0.413	4	6 1/2"	0.472		
	56 C	[114.3]	[149.22]	[5.5]	[10.5]				[165.1]	[12]
502	284/286 TC	10 1/2"	9	0.236	0.551	4	11 1/4"	0.669		
		[266.7]	[228.6]	[6]	[14]				[285.75]	[17]
	254/256 TC	8 1/2"	7 1/4"	0.236	0.551	4	9	0.590		
	213/215 TC	[215.9]	[184.15]	[6]	[14]				[228.6]	[15]
	182/184 TC									
143/145 TC	4 1/2"	5 7/8"	0.216	0.413	4	6 1/2"	0.472			
	[114.3]	[149.22]	[5.5]	[11]				[165.1]	[12]	
503	182/184 TC	8 1/2"	7 1/4"	0.236	0.551	4	9	0.590		
		[215.9]	[184.15]	[6]	[14]				[228.6]	[15]
	143/145 TC	4 1/2"	5 7/8"	0.216	0.413	4	6 1/2"	0.472		
		[114.3]	[149.22]	[5.5]	[11]				[165.1]	[12]



RFV ... H...NEMA

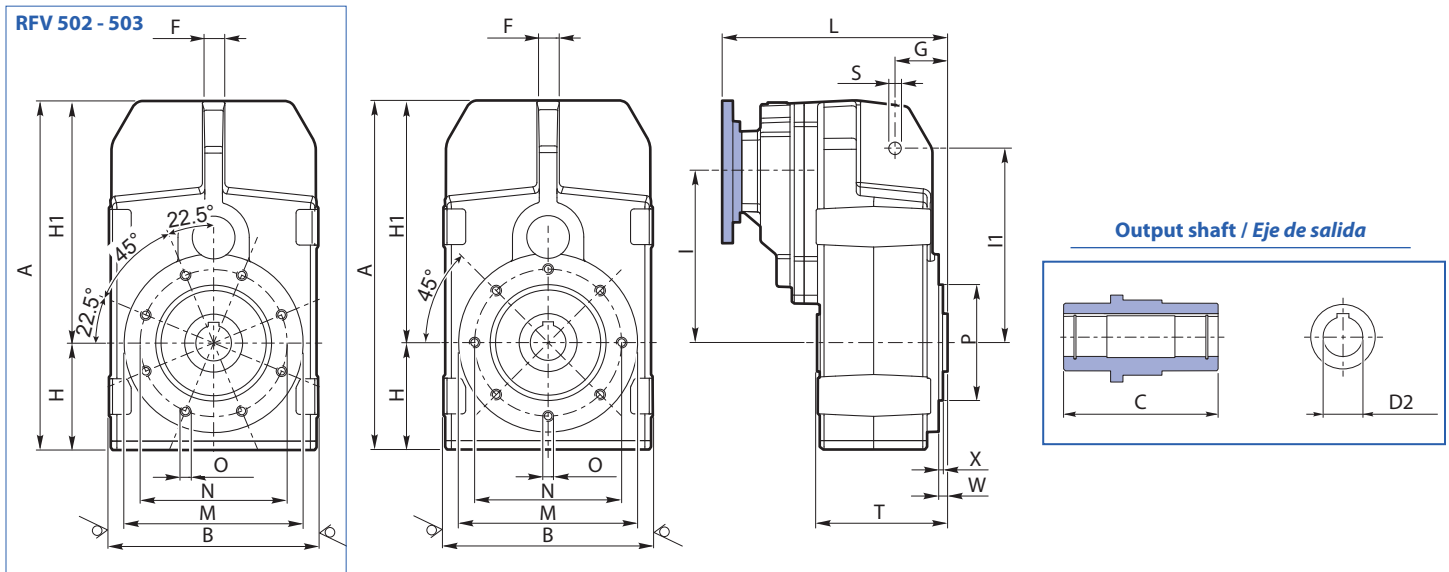

RFV	A	B	C	D2 H7	F	G	H	H1	i	i1	L	M	N	O	P h7	S	T	X	W			
252	inch	10.000	6.693	3.957	1"	0.787	1.378	3.130	6.870	4.646	5.512	7.087	NEMA 56/140	4.724	3.937	M8x0.590 N.8	3.150	0.433	3.957	0.118	0.177	
	[mm]	[254]	[170]	[100.5]	[25.4]	[20]	[35]	[79.5]	[174.5]	[118]	[140]	[180]	NEMA 56/140	[120]	[100]	[M8x15 N.8]	[80]	[11]	[100.5]	[3]	[4.5]	
253	inch	10	6.693	3.957	1"	0.787	1.378	3.130	6.870	5.669	5.512	7.362	NEMA 56	4.724	3.937	M8x0.590 N.8	3.150	0.433	3.957	0.118	0.177	
	[mm]	[254]	[170]	[100.5]	[25.4]	[20]	[35]	[79.5]	[174.5]	[144]	[140]	[187]	NEMA 56	[120]	[100]	[M8x15 N.8]	[80]	[11]	[100.5]	[3]	[4.5]	
302	inch	11.260	7.402	4.724	1 1/4"	0.787	1.575	3.524	7.736	5.362	6.299	7.441	NEMA 56/140	5.512	4.528	M8x0.590 N.8	3.740	0.433	4.724	0.118	0.197	
	[mm]	[286]	[188]	[120]	[31.75]	[20]	[40]	[89.5]	[196.5]	[136.2]	[160]	[189]	NEMA 56/140	[140]	[115]	[M8x15 N.8]	[95]	[11]	[120]	[3]	[5]	
303	inch	11.260	7.402	4.724	1 1/4"	0.787	1.575	3.524	7.736	6.465	6.299	7.756	NEMA 56	5.512	4.528	M8x0.590 N.8	3.740	0.433	4.724	0.118	0.197	
	[mm]	[286]	[188]	[120]	[31.75]	[20]	[40]	[89.5]	[196.5]	[164.2]	[160]	[197]	NEMA 56	[140]	[115]	[M8x15 N.8]	[95]	[11]	[120]	[3]	[5]	
352	inch	12.835	8.268	4.921	1 3/8"	0.787	2.126	3.937	8.898	5.984	6.693	10.709	NEMA 180	5.906	5.118	M10x0.669 N.8	4.331	0.512	4.921	0.138	0.256	
	[mm]	[326]	[210]	[125]	[34.925]	[20]	[54]	[100]	[226]	[152]	[170]	8.858	NEMA 56/140	[150]	[130]	[M10x17 N.8]	[110]	[13]	[125]	[3.5]	[6.5]	
												[272]	NEMA 180									
353	inch	12.835	8.268	4.921	1 3/8"	0.787	2.126	3.937	8.898	7.087	6.693	9.350	NEMA 56/140	5.906	5.118	M10x0.669 N.8	4.331	0.512	4.921	0.138	0.256	
	[mm]	[326]	[210]	[125]	[34.925]	[20]	[54]	[100]	[226]	[180]	[170]	[237.5]	NEMA 56/140	[150]	[130]	[M10x17 N.8]	[110]	[13]	[125]	[3.5]	[6.5]	
402	inch	15.236	9.528	5.669	1 1/2"	0.787	2.224	4.528	10.709	7.539	8.583	11.398	NEMA 180/210	7.874	6.496	M12x0.748 N.8	5.118	0.551	5.669	0.138	0.295	
	[mm]	[387]	[242]	[144]	[38.1]	[20]	[56.5]	[115]	[272]	[191.5]	[218]	11.161	NEMA 140	[200]	[165]	[M12x19 N.8]	[130]	[14]	[144]	[3.5]	[7.5]	
												[289.5]	NEMA 180/210									
403	inch	15.236	9.528	5.669	1 1/2"	0.787	2.224	4.528	10.709	8.799	8.583	10.256	NEMA 56/140	7.874	6.496	M12x0.748 N.8	5.118	0.551	5.669	0.138	0.295	
	[mm]	[387]	[242]	[144]	[38.1]	[20]	[56.5]	[115]	[272]	[223.5]	[218]	[260.5]	NEMA 56/140	[200]	[165]	[M12x19 N.8]	[130]	[14]	[144]	[3.5]	[7.5]	
502	inch	18.701	11.142	6.417	2"	0.787	2.559	5.512	13.189	8.307	10.945	14.114	NEMA 280	9.843	8.465	M12x0.748 N.8	7.087	0.866	6.417	0.177	0.335	
												13.484	NEMA250									
												12.480	NEMA 180/210									
												12.244	NEMA 140									
503	inch	18.701	11.142	6.417	2"	0.787	2.559	5.512	13.189	9.882	10.945	12.402	NEMA 180	9.843	8.465	M12x0.748 N.8	7.087	0.866	6.417	0.177	0.335	
	[mm]	[475]	[283]	[163]	[50.8]	[20]	[65]	[140]	[335]	[211]	[278]	12.165	NEMA 140	[250]	[215]	[M12x19 N.8]	[180]	[22]	[163]	[4.5]	[8.5]	
												[315]	NEMA 180									
												[309]	NEMA 140									



5.9 Dimensions

5.9 Dimensiones

Output shaft / Eje de salida

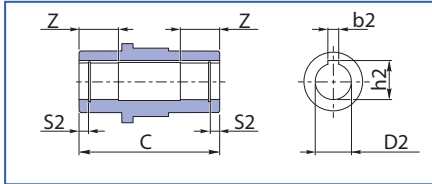

RFV...H...	b2	C	D2	h2	S2	Z	
252	inch	0.250	3.957	1"	1.114	0.283	1.102
	[mm]	[6.35]	[100.5]	[25.4]	[28.3]	[7.2]	[28]
253	inch	0.250	3.957	1"	1.114	0.283	1.102
	[mm]	[6.35]	[100.5]	[25.4]	[28.3]	[7.2]	[28]
302	inch	0.250	4.724	1 1/4"	1.367	0.303	1.220
	[mm]	[6.35]	[120]	[31.75]	[34.7]	[7.7]	[31]
303	inch	0.250	4.724	1 1/4"	1.367	0.303	1.220
	[mm]	[6.35]	[120]	[31.75]	[34.7]	[7.7]	[31]
352	inch	0.312	4.921	1 3/8"	1.518	0.331	1.378
	[mm]	[7.92]	[125]	[34.925]	[38.55]	[8.4]	[35]
353	inch	0.312	4.921	1 3/8"	1.518	0.331	1.378
	[mm]	[7.92]	[125]	[34.925]	[38.55]	[8.4]	[35]
402	inch	0.375	5.669	1 1/2"	1.669	0.398	1.378
	[mm]	[9.53]	[144]	[38.1]	[42.39]	[10.1]	[35]
403	inch	0.375	5.669	1 1/2"	1.669	0.398	1.378
	[mm]	[9.53]	[144]	[38.1]	[42.39]	[10.1]	[35]
502	inch	0.500	6.417	2"	2.223	0.425	1.575
	[mm]	[12.70]	[163]	[50.8]	[56.46]	[10.8]	[40]
503	inch	0.500	6.417	2"	2.223	0.425	1.575
	[mm]	[12.70]	[163]	[50.8]	[56.46]	[10.8]	[40]

RFV... H...FV

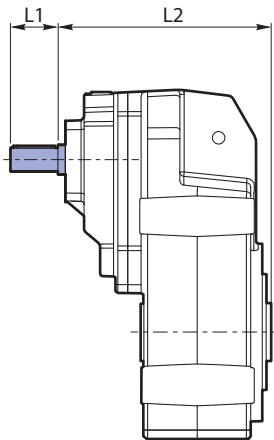

Input shaft / Eje de entrada

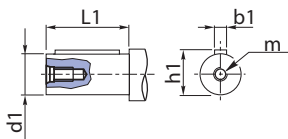

RFV...H...	b1	d1 h6	L1	L2	h1	m	
252	inch	0.187	3/4"	1.575	6.508	0.832	5/16-18 x 0.709
	[mm]	[4.75]	[19.05]	[40]	[165.3]	[21.1]	
253	inch	0.187	5/8"	1.575	6.390	0.704	1/4-20 x 0.630
	[mm]	[4.75]	[15.88]	[40]	[162.3]	[17.9]	
302	inch	0.187	3/4"	1.575	6.862	0.832	5/16-18 x 0.709
	[mm]	[4.75]	[19.05]	[40]	[174.3]	[21.1]	
303	inch	0.187	5/8"	1.575	6.783	0.704	1/4-20 x 0.630
	[mm]	[4.75]	[15.88]	[40]	[172.3]	[17.9]	
352	inch	0.250-0.187	1" - 3/4"	1.969-1.575	9.047-8.193	1.109-0.832	5/16-18 x 0.709
	[mm]	[6.35-4.75]	[25.4 - 19.05]	[50-40]	[229.8/208]	[28.2-21.1]	
353	inch	0.187	3/4"	1.575	8.764	0.832	5/16-18 x 0.709
	[mm]	[4.75]	[19.05]	[40]	[222.6]	[21.1]	
402	inch	0.250-0.25	1 1/8" - 1"	2.362-1.969	10.339-9.705	1.236-1.109	5/16-18 x 0.709
	[mm]	[6.35-6.35]	[28.575-25.4]	[60-50]	[262.6-246.5]	[31.4-28.2]	
403	inch	0.187	3/4"	1.575	9.677	0.832	5/16-18 x 0.709
	[mm]	[4.75]	[19.05]	[40]	[245.8]	[21.1]	
502	inch	0.250-0.375	1 1/8" - 1 1/2"	2.362-3.150	12.854-11.421	1.236-1.664	5/16-18 x 0.709 3/8-16 x 0.906
	[mm]	[6.35-9.525]	[28.575-38.1]	[60-80]	[326.5-290]	[31.4-42.3]	
503	inch	0.250	1"	1.969	11.614	1.109	5/16-18 x 0.709
	[mm]	[6.35]	[25.4]	[50]	[295]	[28.2]	



5.9 Dimensions

5.9 Dimensiones

RFV ... S...

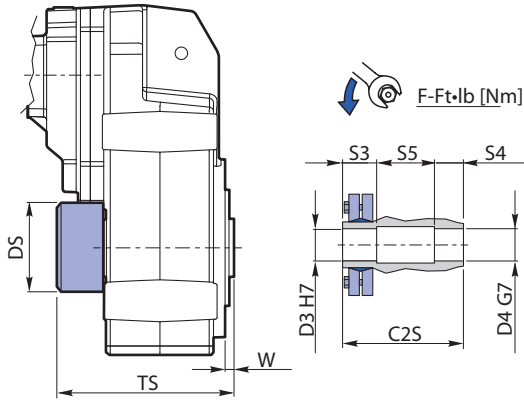

RFV...S...	TS	DS	C2S	D3 H7	D4 G7	W	S3	S5	S4	
252	inch	5.906	2.953	5.512	0.984	1.063	0.177	1.339	2.756	1.417
	[mm]	[150]	[75]	[140]	[25]	[27]	[4.5]	[34]	[70]	[36]
253	inch	5.906	2.953	5.512	0.984	1.063	0.177	1.339	2.756	1.417
	[mm]	[150]	[75]	[140]	[25]	[27]	[4.5]	[34]	[70]	[36]
302	inch	6.772	3.386	6.378	1.181	1.260	0.197	1.496	1.339	1.575
	[mm]	[172]	[86]	[162]	[30]	[32]	[5]	[38]	[34]	[40]
303	inch	6.772	3.386	6.378	1.181	1.260	0.197	1.496	3.307	1.575
	[mm]	[172]	[86]	[162]	[30]	[32]	[5]	[38]	[34]	[40]
352	inch	6.575	3.701	6.181	1.417	1.496	0.256	1.654	2.874	1.654
	[mm]	[167]	[94]	[157]	[36]	[38]	[6.5]	[42]	[73]	[42]
353	inch	6.575	3.701	6.181	1.417	1.496	0.256	1.654	2.874	1.654
	[mm]	[167]	[94]	[157]	[36]	[38]	[6.5]	[42]	[73]	[42]
402	inch	7.441	4.134	7.047	1.654	1.732	0.295	1.909	3.228	1.909
	[mm]	[189]	[105]	[179]	[42]	[44]	[7.5]	[48.5]	[82]	[48.5]
403	inch	7.441	4.134	7.047	1.654	1.732	0.295	1.909	3.228	1.909
	[mm]	[189]	[105]	[179]	[42]	[44]	[7.5]	[48.5]	[82]	[48.5]
502	inch	8.465	4.921	7.992	2.047	2.126	0.335	2.441	3.583	1.969
	[mm]	[215]	[125]	[203]	[52]	[54]	[8.5]	[62]	[91]	[50]
503	inch	8.465	4.921	7.992	2.047	2.126	0.335	2.441	3.583	2.047
	[mm]	[215]	[125]	[203]	[52]	[54]	[8.5]	[62]	[91]	[50]

RFV...S...	252	302	352	402	502	
	253	303	353	403	503	
F	Ft·lb	6.3	10.7	10.7	10.7	10.7
	[Nm]	[8.5]	[14.5]	[14.5]	[14.5]	[14.5]

RFV 252 R...

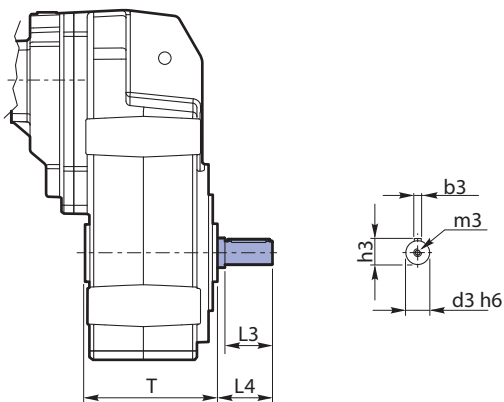

RFV...R...	b3	h3	d3 H6	L3	L4	m3	T	
252	inch	0.250	1.109	1"	1.772	3.012	3/8-16 x 0.87	3.957
	[mm]	[6.35]	[28.17]	[25.4]	[45]	[76.5]		[100.5]
253	inch	0.250	1.109	1"	1.772	3.012	3/8-16 x 0.87	3.957
	[mm]	[6.35]	[28.17]	[25.4]	[45]	[76.5]		[100.5]
302	inch	0.250	1.362	1 1/4"	2.362	3.780	1/2-13 x 1.10	4.724
	[mm]	[6.35]	[34.59]	[31.75]	[60]	[96]		[120]
303	inch	0.250	1.362	1 1/4"	2.362	3.780	1/2-13 x 1.10	4.724
	[mm]	[6.35]	[34.59]	[31.75]	[60]	[96]		[120]
352	inch	0.3125	1.513	1 3/8"	2.362	3.661	1/2-13 x 1.10	4.921
	[mm]	[7.94]	[38.43]	[34.925]	[60]	[93]		[125]
353	inch	0.3125	1.513	1 3/8"	2.362	3.661	1/2-13 x 1.10	4.921
	[mm]	[7.94]	[38.43]	[34.925]	[60]	[93]		[125]
402	inch	0.375	1.791	1 5/8"	3.150	4.429	5/8-11 x 0.42	5.669
	[mm]	[9.525]	[45.49]	[41.275]	[80]	[112.5]		[144]
403	inch	0.375	1.791	1 5/8"	3.150	4.429	5/8-11 x 0.42	5.669
	[mm]	[9.525]	[45.49]	[41.275]	[80]	[112.5]		[144]
502	inch	0.500	2.218	2"	3.937	5.768	3/4-10 x 1.65	6.417
	[mm]	[12.7]	[56.34]	[50.8]	[100]	[146.5]		[163]
503	inch	0.500	2.218	2"	3.937	5.768	3/4-10 x 1.65	6.417
	[mm]	[12.7]	[56.34]	[50.8]	[100]	[146.5]		[163]



Option FL / Opción FL

RFV ... FL

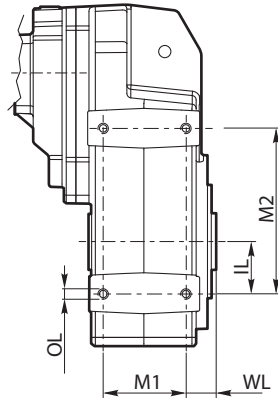
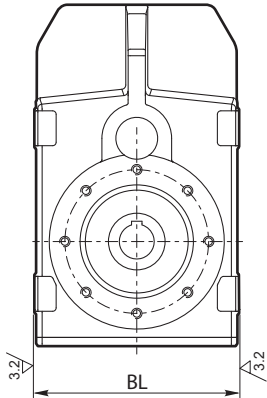

RFV...FL..		BL	M1	OL	WL	M2	IL
252	inch	6.417	2.362	M8x16	0.837	4.528	1.378
	[mm]	[163]	[60]		[21.25]	[115]	[35]
253	inch	6.417	2.362	M8x16	0.837	4.528	1.378
	[mm]	[163]	[60]		[21.25]	[115]	[35]
302	inch	7.126	2.756	M10x20	1.043	5.118	1.575
	[mm]	[181]	[70]		[26.5]	[130]	[40]
303	inch	7.126	2.756	M10x20	1.043	5.118	1.575
	[mm]	[181]	[70]		[26.5]	[130]	[40]
352	inch	7.992	3.150	M12x22	1.181	5.787	1.772
	[mm]	[203]	[80]		[30]	[147]	[45]
353	inch	7.992	3.150	M12x22	1.181	5.787	1.772
	[mm]	[203]	[80]		[30]	[147]	[45]
402	inch	9.252	3.740	M12x22	1.280	7.480	2.362
	[mm]	[235]	[95]		[32.5]	[190]	[60]
403	inch	9.252	3.740	M12x22	1.280	7.480	2.362
	[mm]	[235]	[95]		[32.5]	[190]	[60]
502	inch	10.748	4.331	M14x26	1.378	9.449	2.756
	[mm]	[273]	[110]		[35]	[240]	[70]
503	inch	10.748	4.331	M14x26	1.378	9.449	2.756
	[mm]	[273]	[110]		[35]	[240]	[70]



Output flange / Brida de salida

RFV ... F...

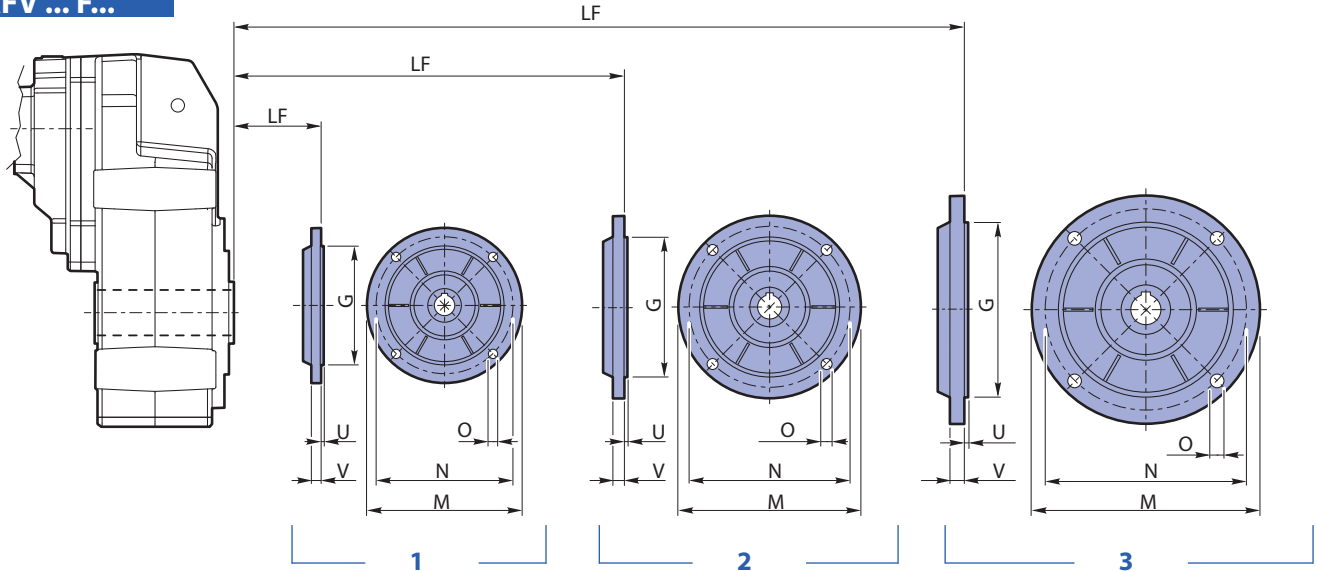

RFV	1							2							3								
	G h8	L	M	N	O	U	V	G h8	L	M	N	O	U	V	G h8	L	M	N	O	U	V		
252	F 160							F 200							F 250								
	inch	4.331	1.240	6.299	5.118	0.354	0.118	0.472	5.118	1.240	7.874	6.496	0.433	0.138	0.472	7.087	1.240	9.843	8.465	0.551	0.157	0.551	
	[mm]	[110]	[31.5]	[160]	[130]	[9]	[3]	[12]	[130]	[31.5]	[200]	[165]	[11]	[3.5]	[12]	[180]	[31.5]	[250]	[215]	[14]	[4]	[14]	
253	F 160							F 200							F 250								
	inch	4.331	1.240	6.299	5.118	0.354	0.118	0.472	5.118	1.240	7.874	6.496	0.433	0.138	0.472	7.087	1.240	9.843	8.465	0.551	0.157	0.551	
	[mm]	[110]	[31.5]	[160]	[130]	[9]	[3]	[12]	[130]	[31.5]	[200]	[165]	[11]	[3.5]	[12]	[180]	[31.5]	[250]	[215]	[14]	[4]	[14]	
302	F 160							F 200							F 250								
	inch	4.331	1.417	6.299	5.118	0.354	0.118	0.472	5.118	1.417	7.874	6.496	0.433	0.138	0.472	7.087	1.417	9.843	8.465	0.551	0.157	0.551	
	[mm]	[110]	[36]	[160]	[130]	[9]	[3]	[12]	[130]	[36]	[200]	[165]	[11]	[3.5]	[12]	[180]	[36]	[250]	[215]	[14]	[4]	[14]	
303	F 160							F 200							F 250								
	inch	4.331	1.417	6.299	5.118	0.354	0.118	0.472	5.118	1.417	7.874	6.496	0.433	0.138	0.472	7.087	1.417	9.843	8.465	0.551	0.157	0.551	
	[mm]	[110]	[36]	[160]	[130]	[9]	[3]	[12]	[130]	[36]	[200]	[165]	[11]	[3.5]	[12]	[180]	[36]	[250]	[215]	[14]	[4]	[14]	
352	F 200							F 250							F 300								
	inch	5.118	1.299	7.874	6.496	0.551	0.157	0.551	7.087	1.299	9.843	8.465	0.551	0.157	0.551	9.055	1.299	11.811	10.433	0.551	0.157	0.551	
	[mm]	130	33	200	165	14	4	14	180	33	250	215	14	4	14	230	33	300	265	14	4	14	
353	F 200							F 250							F 300								
	inch	5.118	1.299	7.874	6.496	0.551	0.157	0.551	7.087	1.299	9.843	8.465	0.551	0.157	0.551	9.055	1.299	11.811	10.433	0.551	0.157	0.551	
	[mm]	[130]	[33]	[200]	[165]	[14]	[4]	[14]	[180]	[33]	[250]	[215]	[14]	[4]	[14]	[230]	[33]	[300]	[265]	[14]	[4]	[14]	
402	F 300							F 350							-								
	inch	9.055	1.280	11.811	10.433	0.551	0.197	0.669	9.843	1.280	13.780	11.811	0.709	0.197	0.669								
	[mm]	[230]	[32.5]	[300]	[265]	[14]	[5]	[17]	[250]	[32.5]	[350]	[300]	[18]	[5]	[17]								
403	F 300							F 350							-								
	inch	9.055	1.280	11.811	10.433	0.551	0.197	0.669	9.843	1.280	13.780	11.811	0.709	0.197	0.669								
	[mm]	[230]	[32.5]	[300]	[265]	[14]	[5]	[17]	[250]	[32.5]	[350]	[300]	[18]	[5]	[17]								
502	F 300							F 350							-								
	inch	9.055	1.831	11.811	10.433	0.551	0.197	0.709	9.843	1.831	13.780	11.811	0.709	0.197	0.709								
	[mm]	[230]	[46.5]	[300]	[265]	[14]	[5]	[18]	[250]	[46.5]	[350]	[300]	[18]	[5]	[18]								
503	F 300							F 350							-								
	inch	9.055	1.831	11.811	10.433	0.551	0.197	0.709	9.843	1.831	13.780	11.811	0.709	0.197	0.709								
	[mm]	[230]	[46.5]	[300]	[265]	[14]	[5]	[18]	[250]	[46.5]	[350]	[300]	[18]	[5]	[18]								



Anti-vibration kit

Kit antivibraciones

The RFV series shaft-mounted reducers can be equipped, on request, with an anti-vibration kit that includes the components required for mounting the reducer (reaction arm excluded).

The dimensions are shown in the table below.

Los reductores pendulares de la serie RFV pueden equiparse bajo pedido con un kit antivibrante, que incluye los componentes necesarios para la fijación pendular (excluyendo el brazo de reacción).

Las dimensiones se indican en la tabla siguiente.

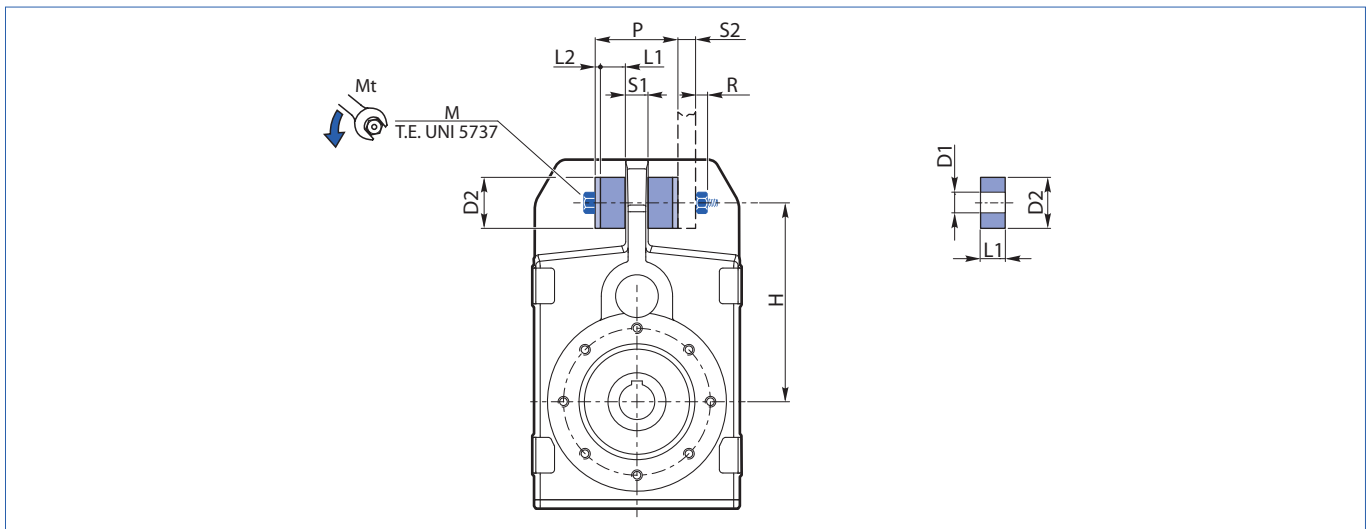

RFV		D1	D2	H	L1	L2	M	P	R	S1	S2 (max)	Mt
252 253	inch	0.433	1.181	5.512	0.591	0.098	M10x80	2.165	0.484	0.787	0.394	7 Ft•lb
	[mm]	[11]	[30]	[140]	[15]	[2.5]		[55]	[12.3]	[20]	[10]	10 Nm
302 303	inch	0.433	1.181	6.299	0.591	0.098	M10x80	2.559	0.583	0.787	0.945	15 Ft•lb
	[mm]	[11]	[30]	[160]	[15]	[2.5]		[65]	[14.8]	[20]	[24]	20 Nm
352 353	inch	0.492	1.575	6.693	0.787	0.098	M12x100	2.165	0.484	0.787	0.394	7 Ft•lb
	[mm]	[12.5]	[40]	[170]	[20]	[2.5]		[55]	[12.3]	[20]	[10]	10 Nm
402 403	inch	0.492	1.575	8.583	0.787	0.098	M12x100	2.559	0.583	0.787	0.787	15 Ft•lb
	[mm]	[12.5]	[40]	[218]	[20]	[2.5]		[65]	[14.8]	[20]	[20]	20 Nm
502 503	inch	0.827	2.362	10.945	1.181	0.197	M20x160	3.543	0.906	0.787	1.850	37 Ft•lb
	[mm]	[21]	[60]	[278]	[30]	[5]		[90]	[23]	[20]	[47]	50 Nm



Sealing cover
Cubierta de sellado

CT

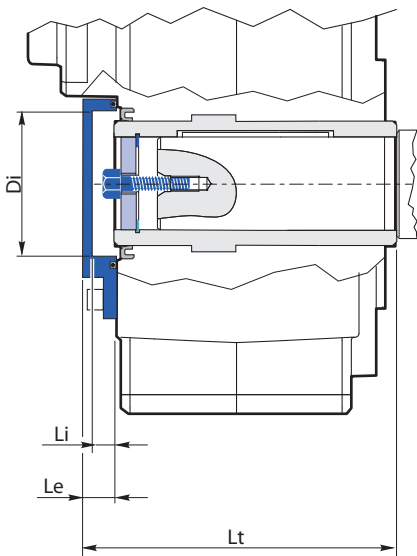
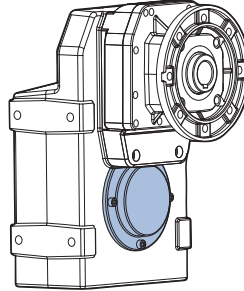

RFV		Di	Li	Le	Lt
252	inch	1.969	0.591	0.787	4.685
253	[mm]	[50]	[15]	[20]	[119]
302	inch	2.165	0.591	0.787	5.433
303	[mm]	[55]	[15]	[20]	[138]
352	inch	2.441	0.591	0.787	5.669
353	[mm]	[62]	[15]	[20]	[144]
402	inch	2.874	0.591	0.787	6.339
403	[mm]	[73]	[15]	[20]	[161]
502	inch	3.543	0.787	0.984	7.283
503	[mm]	[90]	[20]	[25]	[185]

Weights
Pesos

RCV	NEMA	Structural shape / Forma constructiva	
		P	NF
RCV-CV 141	56	5.7 [2.6]	6.2 [2.8]
RCV-CV 191	56 - 140	8.6 [3.9]	9.7 [4.4]
RCV-CV 241	56 - 140	20.7 [9.4]	21.6 [9.8]
RCV-CV 281	140 - 180	39.7 [18]	44.1 [20]
RCV-CV 381	140 - 180 - 210	59.5 [27]	67.2 [30.5]
RCV-CV 162	56	7.1 [3.2]	7.3 [3.3]
RCV-CV 202A	56 - 140	10.4 [4.7]	10.6 [4.8]
RCV-CV 202	56 - 140	19.8 [9]	21.6 [9.8]
RCV-CV 203	56	18.7 [8.5]	19.6 [8.9]
RCV-CV 252A	56 - 140	15.2 [6.9]	15.9 [7.2]
RCV-CV 253A	56	15.0 [6.8]	15.4 [7]
RCV-CV 252	56 - 140	30.4 [13.8]	32.2 [14.6]
RCV-CV 253	56	26.9 [12.2]	29.1 [13.2]
RCV-CV 302A	56 - 140	27.6 [12.5]	27.6 [12.5]
RCV-CV 303A	56 - 140	27.6 [12.5]	27.6 [12.5]
RCV-CV 302	140 - 180	54.0 [24.5]	57.8 [26.2]
RCV-CV 303	56 - 140	51.8 [23.5]	55.6 [25.2]
RCV-CV 352	140 - 180	56.2 [25.5]	60.0 [27.2]
RCV-CV 353	56 - 140	54.0 [24.5]	57.8 [26.2]
RCV-CV 452	140 - 180 - 210	82.7 [37.5]	86.0 [39]
RCV-CV 453	140 - 180	82.7 [37.5]	86.0 [39]
RCV-CV 552	250-280	155.6 [70.6]	149.0 [67.6]
RCV-CV 552	180-210	138.9 [63]	132.3 [60]
RCV-CV 553	140 - 180 - 210	147.7 [67]	141.1 [64]
RCV-CV 582	250 - 280	216.1 [98]	218.3 [99]
RCV-CV 582	180 - 210	198.4 [90]	200.6 [91]
RCV-CV 583	140 - 180 - 210	207.2 [94]	209.4 [95]
RCV-CV 602	280	249.1 [113]	269.0 [122]
RCV-CV 602	180-210-250	244.7 [111]	264.6 [120]
RCV-CV 603	180-210-250	264.6 [120]	284.4 [129]

RFV	NEMA	Structural shape / Forma constructiva	
		H	H+F
RFV 252	56 - 140	23.1 [10.5]	26.5 [12]
RFV 253	56	22.0 [10]	25.4 [11.5]
RFV 302	56 - 140	34.2 [15.5]	37.5 [17]
RFV 303	56	33.1 [15]	36.4 [16.5]
RFV 352	56-140-180	70.5 [32]	86.0 [39]
RFV 353	56 - 140	70.5 [32]	86.0 [39]
RFV 402	140-180-210	104.7 [47.5]	129.0 [58.5]
RFV 403	56 - 140	110.2 [50]	134.5 [61]
RFV 502	250-280	180.8 [82]	207.2 [94]
RFV 502	140-180-210	162.0 [73.5]	188.5 [85.5]
RFV 503	140-180	155.4 [70.5]	181.9 [82.5]

Weight expressed in lb [kg] / Pesos expresada en lb [kg]



08/2020

This catalogue cancels and replaces any previous edition and revision.
All listed data are approximate and it's understood that this entails no obligation on our part.
We reserve the right to implement modifications without notice.

*Este catálogo anula y sustituye cada precedente edición o revisión.
Todos los datos enumerados son indicativos y se entienden sin ningún empeño por nuestra parte.
Nos reservamos el derecho de aportar modificaciones sin preaviso.*

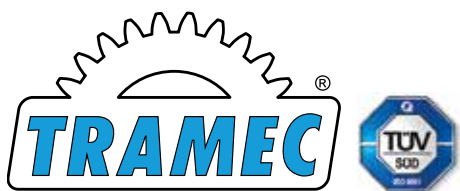

TRAMEC S.r.L.

Via Bizzarri, 6
40012 Calderara di Reno BOLOGNA (Italy)
Tel. +39 051 728935 | Fax +39 051 728937

www.tramec.it | tramec@tramec.it



VARMEC S.r.l.

Via Dell'Industria, 13
36016 Thiene (VI) - ITALY
tel: +39.0445.368532 | fax: +39.0445.370734

<http://www.varmec.com> | info@varmec.com